

ISBN 978-615-5169-16-8 Subspace book (The treatise of existence)



subspace

TREATISE

on the collective unconscious of the universe

The Helix Nebula or Eye of God (Allah) in space "a trillion-mile-long tunnel of glowing gases". At its center is dying star, which has ejected masses of dust and gas to form tentacle-like filaments.

WARNING!

This book contains provocative material
not for children or the sexually immature

*by Professor Desiré
Delicious Dubonnet*

Table of Contents

Subspace Treatise on the Collective Unconscious of the Universe	5
<i>To the Interested Reader</i>	6
<i>Subspace and Prayer as God's Collective Consciousness</i>	8
<i>Intro</i>	9
<i>Start of the Universe</i>	9
<i>Power of Prayer</i>	23
<i>What is Subspace</i>	26
<i>P.E.A.R.</i>	29
<i>New Peridyme</i>	30
<i>Basic Subspace</i>	33
<i>Sacred Geometry of Life</i>	41
<i>The Tree of Life Connection</i>	43
<i>The Vesica Pisces</i>	44
<i>Quantum Biology + Indeterminacy influenced</i>	45
<i>Newton's Calculus</i>	48
<i>Imposed Limitations on Vions Size</i>	57
<i>Verhulst Number (FEIGENBAUM)</i>	58
<i>Dimensional Travel+ Egyptian Wheels</i>	69
<i>Dimensions, Harmonics and the Waveform Universe</i>	70
<i>Wavelength Determines Dimension</i>	71
<i>Dimensions and the Musical Scale</i>	72
<i>The Wall between Octaves</i>	73
<i>Changing Dimensions</i>	74
<i>The Star Tetrahedron</i>	74
<i>Three make two: The Holy Trinity</i>	76
<i>Knowledge is Ever Expanding + Infinite in every Direction</i>	78
<i>Our Sirius Connection</i>	79
<i>A Galaxy's Spiral Arms, Surrounding Sphere and Heat Envelope</i>	81
<i>Precession of the Equinoxes and Other Wobbles</i>	82
<i>Yugas</i>	87
<i>Modern Views on Pole Shifts</i>	87
<i>Iron Pilings and Core Samples</i>	90
<i>Magnetic Flow Changes</i>	91
<i>Harmonic and Disharmonic Levels of Consciousness</i>	92
<i>The Darker Side of Our Present and Past</i>	94
<i>Dying Oceans</i>	97
<i>Ozone</i>	98
<i>The Strecker Memorandum on AIDS</i>	103
<i>The Structure of the Human Brain</i>	106
<i>Mars after the Lucifer Rebellion</i>	107
<i>Martians Rape the Human Child Consciousness and Take Over</i>	108
<i>Minor Pole Shift and the Subsequent Debate</i>	109
<i>The Martians' Fateful Decision</i>	110

<i>Failure of the Martian Mer-Ka-Ba Attempt</i>	110
<i>The Solution: A Christ Consciousness Grid Ascended Masters Assist the Earth</i>	112
<i>A Planetary Grid</i>	113
<i>The Hundredth-Monkey Concept</i>	115
<i>The Hundredth Human</i>	115
<i>How the Grid Was Constructed, and Where</i>	117
<i>Sacred Sites</i>	118
<i>The Appearance of the Heroine</i>	119
<i>Awaiting the Atlantean Catastrophe</i>	119
<i>The Three and a Half Days of the Void</i>	120
<i>Memory, Magnetic Fields and Mer-Ka-Bas</i>	122
<i>Stair-Step Evolution</i>	122
<i>The Tat Brotherhood</i>	123
<i>The Parallel Evolution in Sumer</i>	123
<i>When the Sun Rose in the West</i>	125
<i>The Transpersonal Holographic Memory of the First Level of Consciousness</i>	127
<i>The Introduction of Writing, Which Created the Second level of Consciousness</i>	128
<i>Memory: The Key to Immortality</i>	128
<i>What Really Happened to Akhenaten?</i>	129
<i>The Essene Brotherhood and Jesus, Mary and Joseph</i>	129
<i>The Two Mystery Schools and the 48 Chromosomal Images</i>	130
<i>Genesis, the Creation Story</i>	130
<i>How God and the Mystery Schools Did It</i>	131
<i>First Create a Space</i>	132
<i>Then Spin the Shape to Create a Sphere</i>	133
<i>The First Motion in Genesis</i>	133
<i>The Labyrinth As a Movement of Life-Force Energy</i>	136
<i>The Egg of Life, the Second Shape beyond Genesis</i>	136
<i>The Third Rotation/Shape: The Fruit of Life</i>	137
<i>Combining Male and Female to Create Metatron's Cube, the First Informational System</i>	139
<i>The Seven great Polygons , The Platonic Solids</i>	139
<i>Their Source: Metatron's Cube</i>	140
<i>The Missing Lines</i>	140
<i>Quasi Crystals</i>	140
<i>DNA, the blueprint of all life</i>	142
<i>The Sacred 72</i>	143
<i>Crystals Grounding Our Learning</i>	144
<i>Electron Clouds and Molecules</i>	145
<i>The Six Categories of Crystals</i>	146
<i>Truncating Polyhedrons</i>	149
<i>Buckminster Fuller's Cube Equilibrium</i>	149
<i>The 26 Shapes</i>	151
<i>The Periodic Table</i>	151
<i>The Key: The Cube and the Sphere</i>	153
<i>Crystals Are Alive!</i>	153

Subspace Treatise on the Collective Unconscious of the Universe

The International Journal of the Medical Science of Homeopathy

ISSN 1417 0876 Volume VI issue 2 June 2001

Special Issue on Subspace and Prayer

The International Journals are a medical periodic peer reviewed journal, keeping pace with ever changing health care.

Keeping you abreast, Keeping you informed!

The Best in Practical Homeopathy... Changing Times, Changing Environments... Allopathy vs Homeopathy

Natural + Energetic Medicine



.J.M.S.H, Kálvária Tér 2, Budapest, Hungary Tel: +36 1 303 6-43

<i>The Future Silicon/Carbon Evolutionary Leap</i>	154
<i>The Measuring Stick of the Universe: The Human Body and Its Geometries</i>	156
<i>The Number Twelve</i>	156
<i>The Sperm Becomes a Sphere</i>	157
<i>The First Human Cell</i>	157
<i>Progression of Life Forms through the Platonic Solids</i>	158
<i>The Phi Ratio</i>	159
<i>Studying da Vinci's Canon</i>	160
<i>The Phi Ratio in All Known Organic Structures</i>	163
<i>Golden Mean Rectangles and Spirals around the Body</i>	163
<i>Male and Female Spirals</i>	164
<i>Reconciling the Fibonacci-Binary Polarity The Fibonacci Sequence and Spiral</i>	166
<i>Spirals in Nature</i>	168
<i>Fibonacci Spirals around Humans</i>	168
<i>The Human Grid and Zero-Point Technology</i>	169
<i>Male- and Female-Originating Spirals</i>	170
<i>Keith Critchlow's Triangles and Their Musical Significance</i>	172
<i>Maps for the Left Brain and Their Emotional Component</i>	174
<i>Deciphering the Hebrew Bible Code</i>	175
<i>Hebrew to mathematics in diagram</i>	175
<i>A Sanskrit Poem and Pi</i>	175
Christ as the Word made Flesh	176
<i>Building a 24/7 Prayer wheel</i>	190
I ,Maitreya	191
<i>Conclusion</i>	192
<i>Thanks</i>	192
Reptilian Brain	198
Overview of the brain	204
<i>Brain Wave Entrainment Technology</i>	204
<i>Related Files</i>	208
<i>Geometry</i>	229
Law of Interpretation not Attraction	234
God and The Cosmos	236
Laws Versus Rules	244
Simple Truths	249
<i>What Is Witchcraft?</i>	258

The cost of this book is 78 Euro. The copyright is owned by QX Ltd., all rights reserved.

Please pay to the pay pal under desifm.net under donations. All of the books have low res for size and hi res versions for clarity. If you do not have the money pay what you can, and if you cannot pay anything please pay the cosmos back with good deeds to others. Pass on the good karma by being good to others and helping them the way I am helping you. Pass it on.

To the Interested Reader

The fields of natural medicine, homeopathy, and energetic medicine have received much attention in the last few years. The fear of synthetic chemicals, the ecological damage caused by the chemical industry, failure of antibiotics, realization of the chemical special interest groups ability to manipulate medicine, and an overall developing appreciation of nature, all have brought these forms of medicine into our awareness. Patent synthetic medicine dramatically profits from its synthetic patents, and then tries to get us to believe that the synthetic substance is the same as the natural. More and more people doubt this. The vast body of research included in this reference on quantum medicine is dedicated to offering evidence that synthetics are not the same. There are writings on physics, quantum biology, historical accounts and lots of clinical research. The basic clinical hypothesis is:

Can a medical practitioner use natural products in his practice to substitute for the synthetic medications?

Can a doctor substitute behavioral and homeopathic medicines for synthetic drugs such as synthetic thyroid, NSAID, blood pressure medication, pain killers, antibiotics, antifungals, calmatives, and thousands of synthetic medications on the market today. This is the basic inquiry we pose. The studies are centered around this hypothesis. The results will definitely point to the conclusion that much of modern medicine indeed can be accomplished with the homeopathics described in these research articles. Each of these studies is constantly being challenged and retested by our revalidating staff. Each of these articles on its own is not enough for a drug trial yet, but at present there is enough data to conclude that our original hypothesis is correct. We use these techniques in our clinics on a daily basis with greater success than the old style synthetic medications. These studies represent only a smattering of the thousands of successful interventions we see with homeopathy and behavioral medicine. The basic scientific premise is that nature has many subtle differences that synthetic chemicals do not. There is a measurable and dramatic difference in safety, with natural homeopathic medication having far less side effects. With these ideas in mind we offer the medical and scientific community the volumes of evidence and research contained in this quantum medicine network. Read, Enjoy, Learn, And Think.

Yours Truly

Desiré Delicious Dubounet

Peer Review Staff:

Gylila Panszki, M.D.; Budapest, Hungary Istvan Bandics, M.D.; Budapest, Hungary Richard Atkinson, MCSP, State-registered Physical Therapist; West Yorkshire, England Dennis Higgins M.D. Los Angeles, California, America Max Yang M.D. Taiwan, China Garth Fortune N.D. Perth, Australia Ryan Williams Phd. LBT, Durban, South Africa

Developed By:

The staff of the International Medical University, Natural Education

IMUNE 36-1-303-6043

Fax 36-1-210-9340

www.imune.net

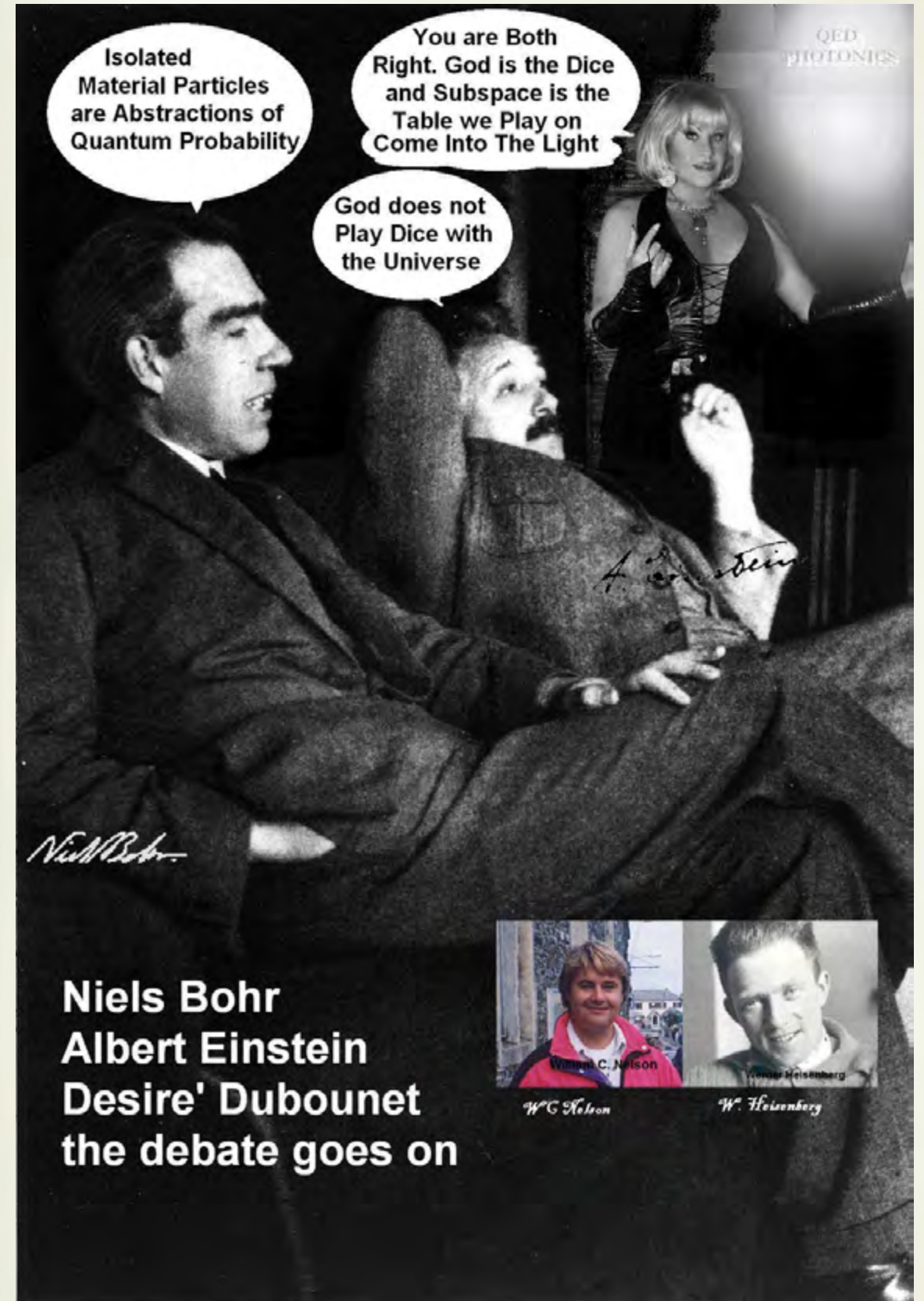

Subspace and Prayer as God's Collective Consciousness

Appendix: In 1981 I designed the first subspace prayer wheel for 24-7 use. On a vacation in Honolulu in 1990, I told my friend Steve Lewis about some of the simple ideas. I then designed his first program. In 1997 I described some of the facts to two of my German friends, interested in Virtual testing. In 2000 I talked to my friend Chris Keser about the same topic. I designed a sample program for him as well. Each of these persons promised me a percentage of the sales, but no one has. In fact I believe that a 24/7 prayer healing program is a great benefit to humanity. I believe that there should be a profound compassionate and empathic person behind this and someone who could do the program at affordable rates and make this available to the masses. Another prospect is the basic technology. There are twelve dimensions involved and each must be affected and properly activated in the program. There is a technology involved and an expertise. The degree of intelligence and experience of the developer is a criteria of choice. I can guarantee that I have the most experience and intelligence in this business. With this in mind, I wish to set forth this treatise as a small example of the technology involved. I will not reveal all of the secrets, but I realize the other persons will want a copy of this treatise. A.S.A.P. The material is often quite mathematical but the connection to the subspace involves and dictates that someone must attend to the mathematics. Mathematics is the essence of our existence.

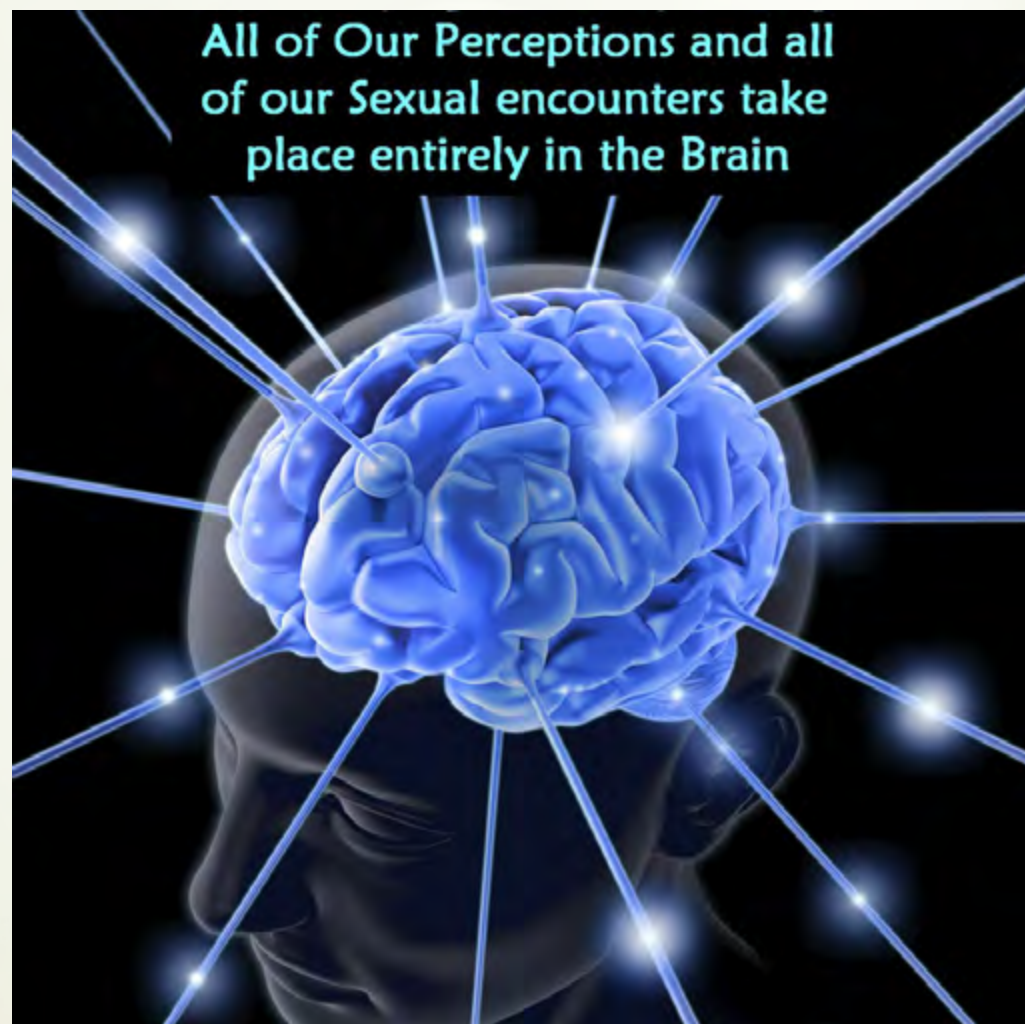

Intro

The mind is the filter of experience. All scientific thought proceeds through this filter. The mind effects all science. The evolution of science must be analyzed through the evolution of the mind. As a man thinketh in his heart so is he. Some people only see what they want to see. The history and development of science must be intrinsically linked to the psychology and intent of the experimenters. It has been demonstrated that observer interference is a basic part of quantum theory. As man develops into deeper knowledge about his environment, the constructs and background of his knowledge allow for deeper insights. A person's perception and interpretation of an experience will always be limited and shaped by the background and filtered by his present knowledge base. Science is shaped by sociology, psychology, and religion, among other philosophies. Many Scientific minds will not be able to accept the thoughts found in this book. They are limited in their perceptions based on their motivation. The main motivation comes from financial goals which must be based in technology, synthetics or something patent able. The thought that prayer or the mind can have power is a conflict with their perception. Their perception is also often based on repeatability, because it is the way to a patent. But life itself is not repeatable. The wise man realizes that you can not step into the same stream twice. The ignorant (those who ignore life simplest fractal truths) will not be able to see this. As people look into philosophy, they develop certain ideas that are a reflection of their knowledge and the psychological intent in developing any investigation. Now with this book, and by bringing philosophy into quantum theory, we can offer a new explanation. The philosophy of quantum theory helps to explain life better than previous theories have.

The overly scientific patent driven tech types are extremely threatened by even the possibility that the mind might be the new arena of technology progress. The treatise of the PROMORPHEUS and this text show that there is an extreme power of the mind that can be released. We can return to the powers of the past ancient cultures. The Subspace technology sets it free. Last year my daughter challenged me to crush a plastic glass with my mind. I reached out and crushed the glass. She said Dad you used your hand. I said I used my mind to control my hand. In true fact all human past +present accomplishments are accomplished with the mind. In fact all things are possible it is only a question of time. Your mind can do anything, perhaps not exactly now, it is always a question of time. But the potential is infinite.

So to the reader, please recognize that your basic attitude and motivation at the beginning will shape your perception of this book. I hope you can free yourself from limitations and perceive the true ambition, decency, purity, sanctity and enthusiasm that has shaped it's construction.

Start of the Universe

In the books Quantum Biology and Bio-Quantum Matrix we offered proof that at the beginning of time there was some type of process that all matter went through, and that a set of laws was imposed onto this matter. Every photon, electron, proton, neutron, quark, and other particle then must obey a fixed set of consistent rules. These rules follow the matrices of a master plan. The universe was at the start just one thing. All matter and all energy was contained in a single point. This would result in a large implosion not an explosion. There was not a "Big Bang" but as I first put forward in 1982 the universe started with an implosion, so I initiated the "Big Suck Theory".

As the universe expanded space energy, mass take form according to the laws of the universe. This set of laws itself now can be viewed as the consciousness contained in every bit of matter. We were also able to show that the universe is a closed material. And at one basic level the universe is still one thing. There are multiple dimensions in our universe but one level or dimension still contacts and unites all things. This we have called the subspace or fundamental glue of the consciousness of the universe. All things are part of this collective unconscious. The combination of matter and energy in the universe produces a joint consciousness of the universe, which is akin to the joint consciousness of all the bees in a hive. Each bee is separate, yet shares some conscious bonding with the other bees, just as all the matter of the universe shares some conscious connection not only in the rules and laws, but beyond them.

At the printing of this book over 300 quality studies have been done on the efficacy of prayer in medicine. Prayer has been shown to have significant effects on sickness. Larry Dorsey reviews this in his book 'Healing Words' by Harpers. The effect is real and medicine and science have to deal with it. There is a God and there is a connecting force of the universe. The existence of other dimensions and a subspace connecting them is a foregone conclusion. There appears to be an ability of consciousness to connect and effect other systems through this subspace.

Now in our text let us try to quantify and understand more fully this consciousness subspace principle by putting it into physics terms.

The indeterminacy principle allows us to quantify this mechanism. As we pointed out in Quantum Biology section, the laws of thermodynamics are invalidated in the fractal world even by nonliving systems. In other words, there is an order that raw matter follows, which disobeys the pure laws of entropy.

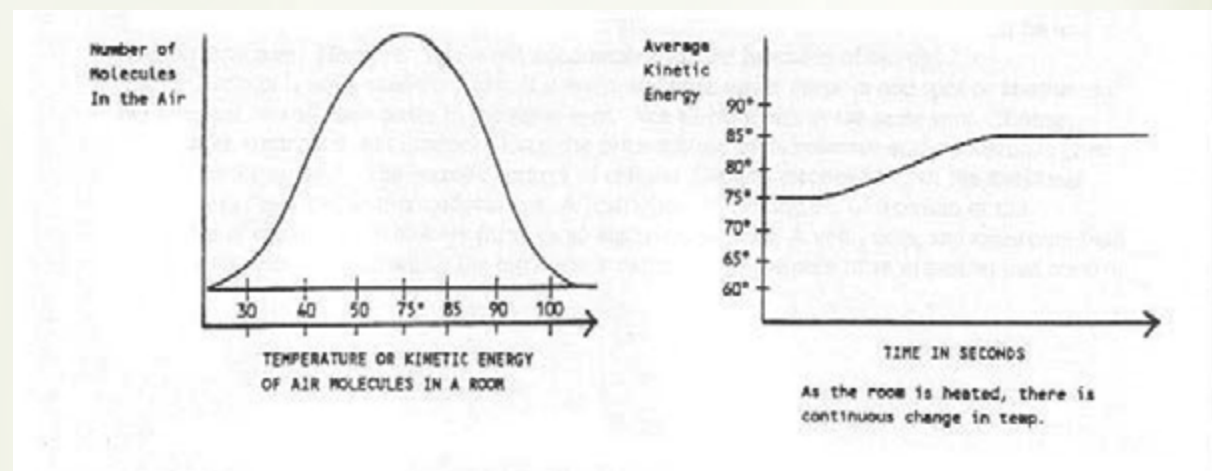

The most astonishing hypothesis is how any intelligent human could overlook this magical transcendent consciousness principle, and suppose that all there is just matter. Some scientists can only see the limits of their own technology and thus refuse to acknowledge the beauty and grandeur of the universe.

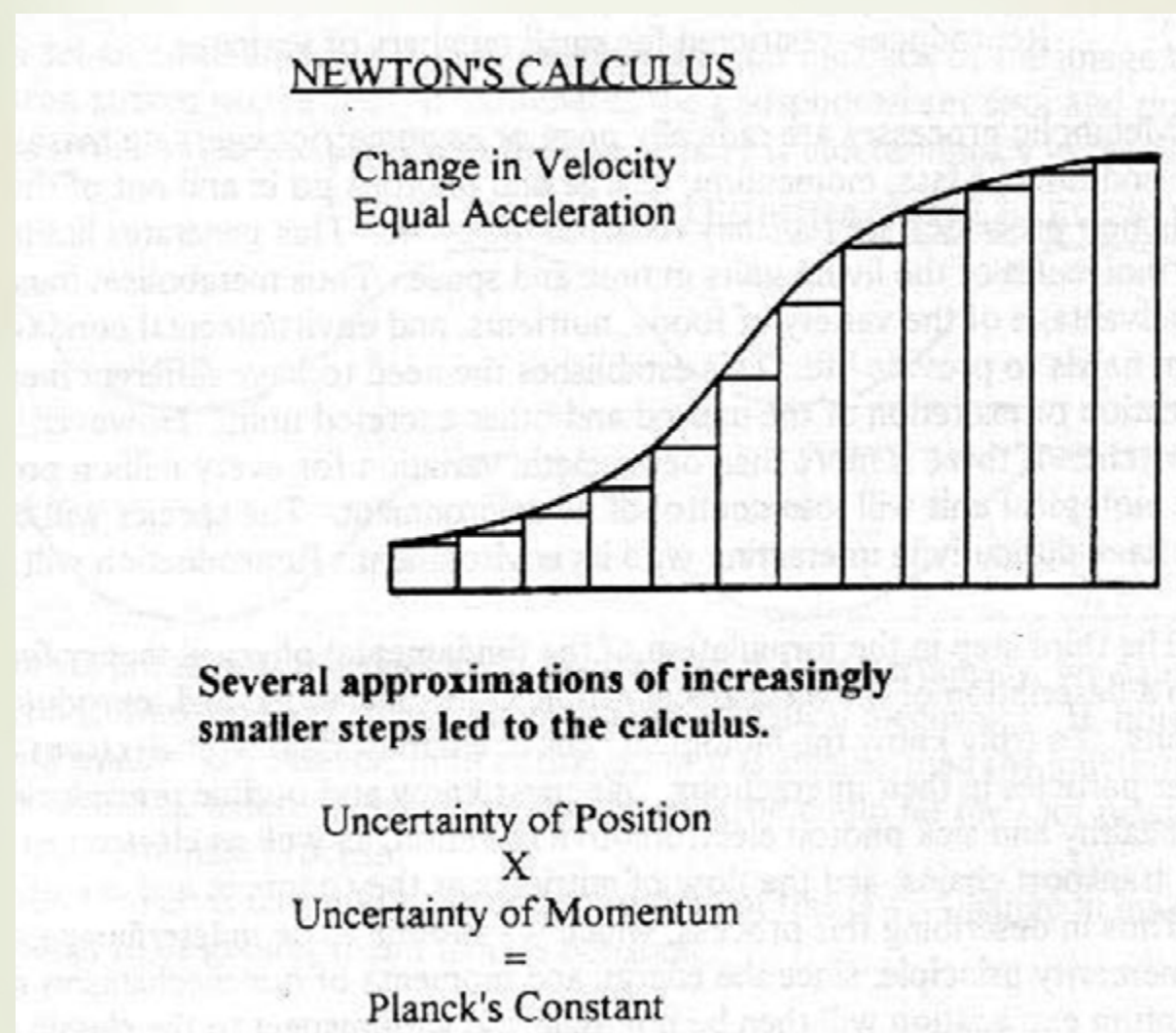

Feigenbaum's work on the fractal theory shows that there is a breakup of matter at a certain bifurcation point, so that matter does not follow a complete entropic Gaussian pattern, but breaks down into some type of organization. This type of organization is magnified when the matter organizes into the structure of organic or living tissue. Here we can see the paramount example of resistance to entropy as matter itself tries to resist thermodynamic, entropic breakdown and produce some type of organization. We can see that all matter according to the fractal dynamics and chaos theory resist this breakdown. We will quantify this resistance to breakdown as consciousness.

Thus as an electron or chemical enters an organic body it becomes more resistant to entropy, and thus gains a higher degree of consciousness. This consciousness grows with different organic tissues. The more the organic tissues try to resist thermodynamic breakdown and produce organization the higher the degree of consciousness. The higher degree of consciousness will produce a larger amount of control over indeterminacy. This we labeled as the Nelson effect in Bio-Quantum Matrix section. The indeterminacy principle inside the interaction of electrons, molecules, protons, etc. may be under some conscious control. The greater the degree of consciousness the more we will be able to control indeterminacy. This is another principle of quantification, allowing us to understand consciousness in scientific terms.

Thus as people learn to control and expand their consciousness, we will see an increase in so-called psychic phenomena, which is literally a control factor over the indeterminacy principle (see Quantum Biology section). As a society starts to grow, if it starts to become transcendent, focus on its consciousness and refine its mental abilities, then it also will be able to control these events.



Throughout sports history we have seen certain sports figures who, in the face of all odds, seem to be able to control the ball, puck, or whatever. In other words, there seems to be some subtle effect that the will of these people can produce. This is another example of the consciousness principle, and how the subtle indenter minacious of a hockey or tennis game can be influenced by a strong-willed, highly developed consciousness. Many sports figures talk about that transcendent time when they "become one" with the ball or the game, and have a deep understanding, effect and interaction with the particulars on the playing field.

This control of the indeterminacy principle, which we call consciousness, also can be utilized in many different forms. These different forms culminated the human being, and also can be reflected through the chakras. The first chakras is a type of consciousness in which the person is trying to survive by getting food and the raw needs of survival. This first raw chakras is an organization state in which the person tries to survive against entropy by getting the food, shelter, and raw constituents of life. This first chakras is also a seed of aggression, as often aggression must be used to survive in a cruel world.

The second chakras is that of a species preservation instinct, or an influence of sex, in which the person tries to preserve the species against entropy and degeneration by copulating and producing offspring. This is a fight against entropy, and a fight to preserve the consciousness of the DNA and the organizational structure itself.

The third, the stomach chakras, is a strong will power center. There are nutritional aspects to this, but it is stronger in its effect on will power in allowing the person to have the will to resist entropy and work towards organization and development of consciousness.

The fourth, the heart chakras, has a social type of influence in which people have the instinct to develop societies, share from their hearts, and unite at the heart level to resist against entropy by developing social networks. We are social beings, and need social networks to function and live healthy lives. This heart chakras is an organization structure that helps to develop the basic instincts against entropy, towards structure and organization, and onward towards development of consciousness.

The fifth chakras is the throat. The throat chakras represents the development of the highly organizational form of speech and speech contact. The power of the word is written about in the Bible. This basic power is another form of consciousness that has echoed throughout the universe since its beginning. This power was then channeled into the production of speech and speech contact in the human being with the help of the organization of this throat chakras or energy vortex. Thus speech is a reflection of the power of the word, which has dramatic effects on our biology and medicine. Dr. Roy Curtain developed the hololinguistic effect, in which he found that the human body had reactions to words that could be demonstrated through subtle energy techniques. This led to the development of the Interro system, which was later improved to a much higher degree in the Quantum Med C.I. system. Thus the power of the word has dramatic effects in enhancing organization in consciousness.

The sixth is the brow chakras, in which the relationship of the biophoton reaches its highest zenith. Here we can see that the photon, which is the communicator of Mitogenic radiation, is highly important throughout the universe, and that this light form also resists entropy and yields towards quantum control. This results in a biological photon detector known as the eye; and other electromagnetic detectors, which go to the point of measuring gravity changes, magnetic relationships, capacitance, and other electronic factors. Thus the brow chakras is another form of organization.

The last is the crown chakras, which results in an organizational structural entity that unites all the other energy vortices. This produces the highest degree of resistance to entropy and development of consciousness.

In our development of consciousness we can see that resistance to entropy will allow us to set quantifiable, measurable developments on the consciousness of various entities.

THE EMERALD TABLET OF HERMES

- I. I SPEAK NOT FICTION, BUT WHAT IS CERTAIN AND MOST TRUE.*
- II. WHAT IS BELOW IS LIKE THAT WHICH IS ABOVE, AND THAT WHICH IS ABOVE IS LIKE THAT WHICH IS BELOW FOR PERFORMING THE MIRACLE OF ONE THING.*
- III. AND AS ALL THINGS ARE PRODUCED FROM ONE, BY THE MEDIATION OF ONE, SO ALL THINGS ARE PRODUCED FROM THIS ONE THING BY ADAPTATION.*
- IV. ITS FATHER IS THE SUN, ITS MOTHER WAS THE MOON, THE WIND CARRIED IT IN ITS BELLY, ITS NURSE IS THE EARTH.*

The Hermetian Emerald Tablet of Desiré

Desiré is the creator, developer and the leading pioneer in the medical art of Quantum Electro Dynamic Biofeedback. By first developing the Quantum Quality Control system of homeopathic electrical signature analysis, then developing the EPFX and the SCIO system of measuring the human Electro-Physiological Reactivity of a patient to the QQC signals, a new medicine of electrical energetic medicine was created. After twenty years of clinical scientific research and millions of safe and effective patient visits the art is firmly established in medicine.

There is no such thing as noise. Noise is only information we do not understand.

Desiré Dubonet

Desiré has been nominated for the Nobel Prize in Medicine for over two decades. Her advances and patents in VoltAmmetry, Electro-Physiological Reactivity, TVEP, and Homeopathy are Legendary and World Renown.

Cross The Line™

000-123-778

002-123

Quantum Electro Dynamic Biofeedback

As is Above is Below...
as Below is Above

Subspace Treatise
on the Collective Unconscious of the Universe

- V. IT IS THE CAUSE OF ALL PERFECTION THROUGHOUT THE WHOLE WORLD.
- VI. ITS POWER IS PERFECT IF IT BE CHANGED INTO THE EARTH.
- VII. SEPARATE THE EARTH FROM THE FIRE, THE SUBTLE FROM THE GROSS, GENTLY, AND WITH JUDGMENT.
- VIII. IT ASCENDS FROM THE EARTH TO HEAVEN, AND DESCENDS AGAIN TO EARTH, THUS YOU WILL POSSESS THE GLORY OF THE WHOLE WORLD AND ALL OBSCURITY WILL FLY AWAY.
- IX. THIS THING IS THE FORTITUDE OF ALL FORTITUDE, BECAUSE IT OVERCOMES ALL SUBTLE THINGS, AND PENETRATES EVERY SOLID THING.
- X. THUS ARE ALL THINGS CREATED.
- XI. THENCE PROCEED WONDERFUL ADAPTATIONS WHICH ARE PRODUCED IN THIS WAY.
- XII. THEREFORE AM I CALLED HERMES TRISMEGISTUS, POSSESSING THE THREE PARTS OF THE PHILOSOPHY OF THE WHOLE WORLD.
- XIII. WHAT I HAD TO SAY ABOUT THE OPERATIONS OF THE SUN IS COMPLETE.

Since there is a measurable entity, and the consciousness can be increased in its effect against entropy and disorganization, we see that two people with focused minds can have a greater effect than one, and that there will be a certain amount of energy evolved from even a group as small as seven thousand, who can get together, refine and focus their consciousness, and have a great effect on the conditions of the world. This is what happened in the transcendental meditation movement, in which the Maharishi trained many people in Iowa of consciousness attainment, and then at periodic times would have them get together in a group, to produce a highly productive conscious state that could influence the indeterminacy of other factors throughout the world. This subtle influence could produce a high degree of organization and control, resulting in some rather profound changes in our society including the fall of the Berlin Wall and many other factors. This could have been influenced by the TM movement people in their development of consciousness.

As we pointed out in Quantum Biology section, disease is merely a breakdown in the body's ability to resist entropy and disorganization. Thus consciousness, which resists this type of disease structure, will develop into a new refined form of medicine. Conscious vibrational medicine will also have profound effects in helping patients to overcome a variety of entropic diseases.

The abstract of the original study on subspace communication.

The Trivector Signature of Human Beings as a Basis of Psychic Communication

Researcher: William Charles Nelson. 1974.

This study is done at Youngstown University and published in the Graduate journal June 1974.

the books **3D Views on Natural Cancer Therapies**

**Immune Stimulation
The True Health Care Debate**

Years ago I was excited to see some infomercials about alternative medicine treatments for diseases. The speaker talked a good show and sold me to buy his books. But there was absolutely no real advice in the books, only multilevel companies with more to buy. This made me angry and then I decided to write the best self help books on natural medicine. Editing and collecting the best in real substantiated advice.

Desiré has written two incredible books and made movies to go with them. What to do for influenza and specifically what to do when the next major virus hits. A movie and a self help book designed to really help you and your families understand what to do to protect yourself.

Also cancer is such a devastating disease, and there are ways to help yourself in the kitchen with cooking for cancer patients. Full advice from soup to nuts on exercise, meditation, cooking, and more. Coupled with a video for the science of how it works.

The health care debate is bringing a question of health and care. In this incredible new book Desiré has outlined a very thorough review of the real problems of Health Care. This book will tell you the truth the chemical companies do not want you to hear.



video goes with the book

3D Views on Natural Cancer Therapies



Immune Stimulation



The True Health Care Debate



Subspace Treatise on the Collective Unconscious of the Universe

Abstract

In this study 40 pairs of intimate friends (that is married people, couples going steady, very, very close friends) were involved. One of the pair was put into a dark room in a building in Youngstown State University. A stroboscope and a siren was placed into the dark room next to the ears and eyes of the person. At random times over the course of a two hour plus+ session, a one minute signal of stroboscopic burst and siren's scream would be initiated, subjecting the patient to a fluctuation that would initiate a evoked potential brain wave response. This would provide a startle to the system, a threat to the system that, although safe, would be interpreted by the patient as possibly life-threatening. This would produce a hormonal and nerval reaction and would it would be discernible by their friend. The other person in the group was placed in a separate building at Youngstown state campus. The separate building was needed to make sure that there was no electrical artifact in the electric measures that could be detected. This person was hooked up to a polygraph device capable of measuring the brainwave, the heart rate, and the galvanic skin response. Thus we were measuring voltage, amperage and resistance (VAR). During the two hour plus session the person hooked to the polygraph was to make verbal guesses as to when they thought their friend was being subjected to the evoked potential shock. At the end of the article we will show that the verbal guesses were less than chance. In other words there was no verbal ability to understand what was going on. However, there was always an electrophysiological voltammetric plus resistance reaction that could be discerned. There was a over 90% correlation to a type of electrophysiological (VAR) reaction that could be determined. Thus, the article could show that there was a type of psychic communication. It was seen to be isolated from verbal, conscious pathways and was more of an unconscious bioelectronic signal.

Within the concepts of this book we have expounded on how mass, vibration, and all forces of the universe have a constant blend. Biology had the twenty-three chromosomes to produce the full chakras and the high degree of mental ability to intuit and understand this process. Thus biology had the solution for the unified field theory in its twenty-three chromosomes that allowed it to develop the intellectual consciousness to start the understanding process needed to develop this unified field theory.

Consciousness medicine will also have very spiritual ramifications, in that people will need to understand the spirituality of the grand consciousness of the universe, which many cultures call God, in order to focus the consciousness development in themselves. Whenever any one entity or small group thinks that it is God, and tries to control things itself, this is the grand sin, and will produce drastic repercussions.

This is what happens in the chemical companies when they make synthetic pharmaceuticals; they try to act as if they are God to produce things compatible with the human system. We will see that every natural vitamin, chemical, and herb has its consciousness as well, because it came from an entropy-resistant organism that had a degree of consciousness. Inside the test tube these synthetic chemicals do not have that degree of consciousness; thus they are incompatible with the human body. For some therapist to think that he is God is also a mistake, because the consciousness power of the universe is phenomenally overwhelming in comparison to the consciousness of any one man or small group.

THE MIND CAN
DO ANYTHING...

"It is not the will to win that makes a winner, it is the will to prepare"

Bobby Knight

"There is one great unknowable, imponderable and ultimate incomprehensible unfathomable secret, the ultimate power of the human mind. But please be humble. The mind is like a drop in an ocean. The drop has all of the characteristic of the ocean, but it is a mistake to think it is the same as the ocean..."

Desiré Dubounet

"When two or more share a Dream, we call that Reality"

John Lennon

...IT JUST TAKES TIME

Only through development with the consciousness of the universe can we reach the highest degree of development. Only through humility can we truly develop the highest degree of rapport, and focus this in the system.

In this book we have shown that the electromagnetic radiation has six vector components; three that are reflected in the electromagnetic and static dimensions and three that are scalar or virtual, in that they are hidden from our normal perception. These act through other dimensions. There are four dimensions of length, width, height and time, and six other virtual dimensions of time and space, which make up the entire universe.



We would also like to mention in this book the definition of consciousness, the inert ability of matter to ascend away from thermodynamic entropy and breakdown into an organized system. As consciousness develops it resists against thermodynamic breakdown and starts to control indeterminacy. Controlled indeterminacy can be achieved through the development of consciousness.

In developing a consciousness medicine we must look at ways that one conscious human system can affect the subtle electron, photon, proton, ion and other energies of another system; and affect the indeterminate action, thus having subtle ways of improving the health of another human being. It must be pointed out that these techniques are usually not magnificent and grand, but are usually very subtle, hard to measure, and hard to replicate. This is the dimension of the system that we describe in a consciousness medicine.

The Angel Desire ' and her Butterflies can teach you the

Super Powers of the Mind

and set you free

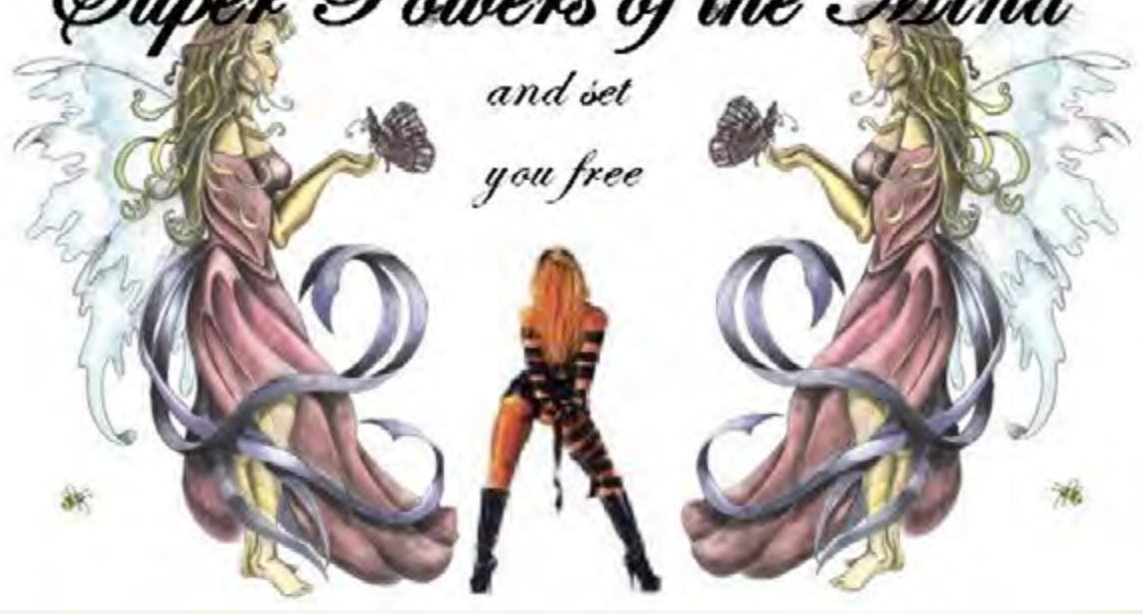

In Quantum Biology we outlined how psychic experiments can be done with indeterminate systems to allow us to measure the degree that any one person might be able to affect an indeterminate system, and help to shape the outcome. This can be used to help in measuring consciousness, in that the higher the degree of consciousness of a person the better his ability to control and affect indeterminacy. This will allow us a way to quantify a consciousness effect, breaking it into mathematical terms. As we have shown in this book, we have used modern physics to account for some of these avant garde forces in biology, and we have used a physics system to analyze these forces and produce ways of controlling them through a scientific process.

As outlined in Quantum Biology and Bio-Quantum Matrix, sections the Nelson effect is the ability of a human being to use the endorphin receptors and other parts of his being and consciousness to transmit information and control indeterminacy in systems at a distance. The control of indeterminacy in systems can transcend time and space, thus making it other-dimensional in some of its activity.

These types of thoughts that go beyond the limited system of classical physics into a Newtonian system challenge the world and its forms of medicine. Physicians and most scientists have long been rooted in the classical dynamics of a Newtonian thermodynamic analysis, which now must be left by the wayside as medicine expands beyond the limitations of that antiquated system.

Many cultures and religions have developed systems of consciousness which can be useful in guiding a practitioner to a new height of consciousness. In many religions meditation is used to focus the mind internally to maximize consciousness. Meditation systems often use awareness channels by minimizing them and reducing external control, and maximizing them, focusing on external events (such as the walking meditations of Eastern schools).

Some common denominators in these systems involve non-judgmental awareness cultivated through systems of love, compassion, introspection, and art. Often these systems also utilize body exercises such as dance, martial arts and the like to help affect the system towards a higher degree of consciousness.

It is not the purpose of this book to go into intricate detail on developing these systems. That will be left to another book at a later date, when we can go into systems of consciousness building and how they apply in medicine and self-growth.

In quantifying the effect of consciousness medicine we should set a couple of standards for our definitions. Let us assume that the standard of focused consciousness, which we will now refer to as FC, can be achieved by certain human beings after years of training of their minds. This is what has happened to certain meditation masters including certain Buddhists, ECK masters and others. Once at this pinnacle level, let's call this FC standard that someone can achieve the ability of a focused consciousness, regardless of whether one meditation master is better than another. We are concentrating on the ability of this focused consciousness to affect indeterminacy beyond the time and space models of normal physics.

Negative emotions will deter from the focused consciousness. Some of them are anger, greed, delusion, anxiety, worry, jealousy, fear, selfishness, and sadness, among others. These negative emotions (NE) will have an inverse effect on the FC. Thus the ability of this focused consciousness to affect indeterminacy will be $FC \div NE$.

The effect on indeterminacy is still not a direct relationship, in that the effect of the FC can still not totally control the indeterminacy of a situation. The effect is rather the cube root of the FC divided by NE. $\text{Percent effect on indeterminacy} = \sqrt[3]{\frac{FC}{NE}}$ Thus as FC tends towards one hundred percent and NE tends towards 0, we can see that the percentage of effect on indeterminacy will approach about ten percent, which is the maximum one person can achieve in his ability to enhance and affect indeterminacy.

Next we must deal with the number of people. If two people join together with focused consciousness, their effects on indeterminacy can be increased. If we take the total number of people in a situation (Tn) and compare that to the number of focused minds (Fn), we now see the following:

$$100\% \sim \left(\frac{T_{sub n} \sim F_{sub n}}{T_{sub n}} \right) \sim \sim FN\%$$

We can see here that the percentage in a total population of focused minds can be delivered by the total number minus the focused number divided by the total n.

If we substitute the total percentage of focused minds into our original equation, we now come to:

$$\{\text{Percent of Social Effect \# O\&L n Indeterminacy}\} \sim \sim \sqrt[3]{\left\{ \frac{(F_{sub n} \%)}{NE \sim (total)} \right\}}$$

Here we take the total of the square root of the percent of focused minds divided by the negative emotions to achieve the percentage of social effect on indeterminacy. If just one percent of the total population

can become focused, it can have dramatic effects on the ability of society to affect indeterminacy, and thus become a resonant contagious factor that can help to pervade the quality of focused consciousness into the total.

In a cybernetic system, as we pointed out in Quantum Biology, it just takes a small effect on indeterminacy to go from entropy into control. Once into control the small effect can challenge the system and resist the entropic thermodynamic breakdown, even at a society level. So we can see the effect that shared consciousness and focused minds can have on the world.

To experimentally challenge this hypothesis we can now look at people with focused minds, as in some of the Targ and Putoff experiments and other psychic phenomena, and see the ability of these people to affect certain indeterminate events, such as the spin of a roulette wheel, the cast of dice and other indeterminate events. The connection through these events is not a direct effect on the dice, but rather a shaping of the indeterminate outcome. If we challenge these meditation masters, we will see that the above equation holds out, and that they have the ability to affect the situation within ten percent.

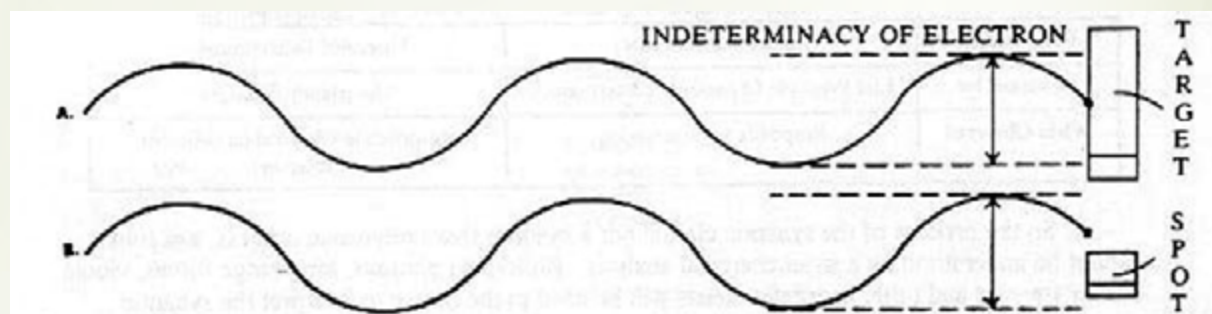

This allows them to increase their probability and chance of outcome. We see that they cannot totally control the indeterminate events, but they can have an effect on the events through the Nelson effect. Thus we have experimentally validated the above formula.

For a review of statistics we point the reader to a review of psychic research.

We can also see the effect that society has by some collective meditation masters of groups such as the TM movement, and how their efforts are capable of shaping the indeterminate events of society.

This effect is small and measurable; yet it is unreliable for its form of indeterminacy effect. We can also see that negative emotions, even by the researchers, can have derogatory effects on any type of experiment. So if we were to do this experiment in a laboratory in which the researchers did not expect outcomes, or if there were disbelief and negative emotions by others, the experiment might be affected adversely.



What you see is a reflection of what is in you

Power of Prayer

Prayer has been used in healing as long as there has been a human race. The power of prayer has now been documented in medical literature in over 300 major peer reviewed studies. People who are prayed for have slightly better results than those who are not. Larry Dorsey, a MD, wrote of this and explains that the prayers work best when they are of a certain quality of mind. We have outlined in the PROMORPHEUS that there is a subspace backdrop dimension of the universe that permeates and allows consciousness.

PROOF *of the* POWERS

of the MIND

1. Test of Time
2. Quantum Theory
3. Placebo Effect
4. What we don't know is so vast
5. Bell's Theorem
6. P.E.A.R (Princeton Engineering Anomalies Research)
7. The people who do not believe in the mind always find that conclusion
8. Researchers that disbelieve are psychologically unstable or they have a hidden agenda

*Desire
Delicious
Dubouret*

This consciousness subspace can allow transfer of energy or information in ways not understood by the limited classical physics. Our subspace and quantum physics can explain this process however.

All things share the subspace of consciousness, but quantic objects with complex fractal indeterminacies are more sensitive. These type of quantic system objects then have so much more consciousness that we by social agreement call them conscious. Could we program a computer to have more of this consciousness and then enable it to pray for the healing of others. We first have to provide for a true indeterminacy, because the random function in computers now is not truly random. It is based on the timer and as such is unreliable as a quantic indeterminacy generator. This can be compensated for. Then we must provide a back drop of the right sounds, frequencies, and words that people have found in all of our cultures to be of the right quality. Cross cultural comparisons have shown several common denominators of shared experience in the development of perfection of prayer. The computer must have Karmic backlash safeguards. Safeguards to protect the healer and the patient from negativity. Finally this must be tied into a repetitive process in the computer and tested in operation. All of these things have been accomplished by the Quantum Med Consciousness Interface.

Please understand there is absolutely no poison, evil or anything harmful or even unconstructive in the prayers or in my heart. There is no malevolence or cruel word or phrase or thought in the prayers. They are merely a mirror and an amplifier that send all such poison back to its source three times three fold. This is for the patient, the therapist and the developer and family of the developer of the program. There is no malice and evil poison in the software or in my heart.

Therapists applaud me and love the protection. Most thank me for protecting them, and appreciate the use of natural karmic law to help them.

But the evil ones lurking in the shadows sniveling with fear, envy, hatred, jealousy, delusions of grandeur, greed, anger and delusions. They are the source of the poison of which you speak and they don't like the karmic fact that they must face their own poison three times three.

The software calls on all of the positive God consciousness of the cosmos and the positive collective unconsciousness of the universe to protect the patient, the therapist, the developer and all of their families. Very sophisticated prayers designed with the secrets of the ancients and the powers of light.

Each device doing 10 to the 9 prayers every second, 31,000 devices operating an average of 3 hr a day 90 min or 5400 sec times, that is 167400000 prayers per day 1.7 time 10 to the 8th times 10 9th

1.67 times ten to the 17th prayers every day, 6.1 times ten to the 20th prayers per year more than all of the stars in the sky.

The good people love this and they know that we can help to heal this planet with prayer. The prudent people respect karmic law and know how it works. They know that evil returns to the evil heart. The good people know that there is no ugly evil in a mirror, but for people with evil in their heart they see ugliness in the mirror. They think the mirror is ugly because that is what they see. What they see is in their own heart. And this is part of the growth of the universe.

Who would be bothered by a pure positive prayer wheel designed to protect people? Only the one with evil backbiting poison, for they and only they would be or need be concerned. Only those with evil in

the heart should be anxious. For what they fear is themselves. The mirror is but a way to grow it is not poison. The poison exist in the hearts and minds of the jealous, greedy, angry, deluded people unable to deal with their own mental instability. My waters are still so they act as a mirror. I wish you growth and may God find a way to still your greed and anger and open your eyes to face your false beliefs.

What is Subspace

When Planck, Bohr, Schrodinger, and a host of others proved the undeniable existence of quantum theory, it shocked the scientific world. When Heisenberg proved the indeterminacy of this quantum theory, it shook the scientific world. Einstein could not accept this theory. He said " I do not believe that God plays dice with the Universe". Einstein believed in a cohesive force of subtle control of the universe. A true genius is often times just some one who can see that two seemingly opposite theories can actually be expressions of a third theory. Einstein did this by recognizing that a falling body to one observer might be a body at rest to another. He did not live long enough to so analyze quantum theory. With this more intellectual flexibility now let me review the problem.

Heisenberg found an elegant mathematical equation that could distinctly point where Newtonian physics was valid, and where Quantum mechanics was needed. In the quantum world indeterminacy or uncertainty was undeniably present. Scientists found that when they set up experiments within the quantum limits from Heisenbergs's equation, that their seemed to be a large experimenter effect. The minds of the experimenter could effect the experiment.



Over the last century medical and biology experimenters have also discovered the ability of the mind to effect experiments. The double blind became a hall mark of medical experiments. The double blind has also been brought into quantum experiments. Researchers on brake pads don't need double blind. In fact

the experimenter effect in Newtonian Experiments seems to be limited to the interpretation of data not the experiment itself. In this text (Promorpheus) we attempt to prove the quantum nature of biology and thus of the human body. Then we can see that the experimenter effect of biology and quantum theory might have a similar origin.

Every culture that has ever existed has expressed some belief in psychic phenomena of some form. Extra sensory perception has been shown experimentally to manifest some small effects. Stories of ESP events echo through the history of man. This has lead to some more recent discoveries that people with their minds can effect quantum indeterminate experiments. This phenomena appears to be independent of electrons, photons(EMR), or other forms of known information transfer. The phenomena are independent of time and space as we know it.

Mathematicians describe subspace as a multi dimensional set of possible geographic space superimposed under our universe. Feyneman described the virtual photon as coming in and out of this subspace. Subspace can be seen as a polymorphic or shape defining constraint on the elements of our universe. What holds the elements of our universe in forms must be some basic force. The uncertainty of these elements must be affected by some constraint. This constraint could be a polymorphic effect of a subspace. This subspace could be consciousness or a form of consciousness of our universe. Thus a structure could be imposed on the elements of the universe by a subspace continuum. In this book we calculate the gravitation force of consciousness and propose a unified field theory based on this subspace.

So if we tie in all of the ideas we can see that quantic systems like the human body might be in touch with a consciousness subspace. Consciousness affects quantic systems and indeterminant systems can be affected. There is a subspace of consciousness imposing a structure onto the basic elements of our physical universe. Einstein and Bohr were both right. There is an apparent indeterminant quality of this universe but it responds to and intertwines with consciousness. This book although lengthy is designed to delve into all of the ramifications of this theory for biology and medicine. In our analysis we explore the medical fallacies of basing a medicine on Newtonian chemical systems. We can also uncover other medical systems more in tune with this new theory of medicine.

Hahneman proposed that all disease was caused from other dimensional effects. This could be seen as an expression of our basic theory. Radionics has long been a controversial science that speaks in similar terms to our theory. In radionics a person can affect another system at great distances in ways that modern Newtonian physics can not explain. To date these radionic systems have had a rather severe flaw. They have depended on the quantic system of the human operator. They use some subtle muscle control of the operator to operate. So they use pendulums, rub pads, muscle testing, point probes, or other human interventions to perform. This imposes a great limitation in accuracy and it allows for the human unconsciousness to intrude.

Attempts can be made to reduce this intervention but they are ultimately futile and the dark qualities of the human unconscious of the operator will eventually take control and enjoy it. Then the human operator's unconscious can dump and project it's own dark qualities onto the patient. Intrusion into this subspace will then be possible by designing the right subspace communication system. In this book I intricately show the process of the development of such a devise. This devise has been experimentally evaluated and registered as a medical devise for medical diagnosis and treatment. This represents

over twenty years of my life struggling to perfect this subspace theory and a medical system designed within its' parameters. The modern science of chemistry has used the rods and balls analogy to teach chemical combinations of elements. This implies that the hard object of the ball attached to a rod is an example of how elements combine to make molecules. This was taught because the minds of the students could not grasp the quantic probability of the situation but needed a Newtonian example for a link to understanding. The problem of using a Newtonian model is that it reinforces a Newtonian model and perpetuates a misunderstanding. The true nature of a molecule is beyond Newtonian understanding. What actually happens when a molecule is made is the interaction of vibrational energy probability quantic fields. This is radically different from the rods and balls example. The teaching of biophysics needs to change.

DNA research has also perpetuated the rod and ball approach. The amino acids of DNA are viewed as having a Newtonian predictability. A predictability that can not exist under quantic theory. Genetic coding seems toobey rather distinct Newtonian like rules. But the size and shape of the molecules are quite evidently Quantic in nature. Being Quantic they must be indeterminant and uncertain. The certainty of genetic DNA information transfer must be influenced by some other non Newtonian, submolecular, subspace effect. This effect is definitely beyond Newtonian explanation. There must be an effect on the probability of the quantic nature of these molecules. Our subspace theory can offer a potential explanation. This book offers insight to the nature of a unified consciousness field controlling the subspace of the Molecular exchanges necessary for life.

The current science is limited to electrons, photons(EMR) and other polymorphic communication. Since this system is still in its infancy and only one researcher is developing such technology, we hope that more researchers and developers can be attracted. This technology can represent a dramatic leap for our science and medicine. If we use the Heisenberg uncertainty mathematics on the synaptic cleft below the result is the conclusion that thought is quantic.



P.E.A.R.

P.E.A.R. - The Princeton Engineering Anomalies Research laboratory research founded in 1979. Founded by Robert Jahn , a professor of aerospace sciences and dean emeritus of the School of Engineering and Applied Sciences and Dr Nelson from Kansas. The research data base is now huge by any standard and is impeccable engineering science. The focus of the research has been to explore the relationship of human consciousness to mechanical devices, especially devices with random sequencing generation capacities. Research has without a shadow of doubt shown that there is an interaction that takes place and that the interaction becomes more evident the larger the sampling of effect. The following is a quote from a book entitled "Cybergrace" and gives some insight into the male /female support concept from the scientific point of view at P.E.A.R. known systems as ways of transferring information. But ESP and radionics have fully shown that other ways of communication are possible. Since the system of this communication is depends on the human there are as we have shown limitations. These Fractal Quantic systems are all not easily repeated, but the human systems are even more prone to unreliability. Our new device is not dependent on an operator and thus is much more accurate and reliable. This offers a new form of information retrieval and transfer through subspace.

The anomalies that P.E.A.R. records demonstrate normal

people – ordinary folks with no special abilities – can influence the behavior of electronic devices simply through their consciousness. The most successful operators, however, are those who achieve some sort of identification or resonance with the machine. It does not matter if they are meditating or eating a sandwich, if the resonance is there, the results are stronger. This state of resonance was described by one operator as a state of immersion in the process which leads to a loss of awareness of myself and the immediate surroundings, similar to the experience of being absorbed in a game, book, theatrical, performance, or some creative occupation. Another operator said "I don't feel any direct control over the device, more like a marginal influence when I'm in resonance with the machine. It's like being in a canoe, when it goes where I want, I flow with it. When it doesn't, I try to break the flow and give it a chance to get back in resonance with me".

An interesting and provocative sub note to the issue of resonance is the fact that when two operators who have a certain resonance with each other run trials-such as two people who are in love-the results are dramatically stronger The combined energy of two minds seems to exert a stronger force , for lack of a better word. Another related twist is the discovery that both men and women, or both the masculine and the feminine aspects within us, seem to be necessary to achieve dramatic results. Dunne explained that women more frequently report feeling empathy with the machine , while men report that they are more capable of creating and focusing on a clear set of intentions .Those trials in which both a high degree of empathy and clear intention were present created the largest anomalies.

P.E.A.R.'s data , though aberrant from the perspective of mainstream science, is solid stuff .Skeptics have tried to debunk it ,but the scientists at PEAR are too careful and have amassed too much data over time to simply throw it out as irrelevant .PEAR's data strongly indicate that a palpable relationship exists between human consciousness and digital machines .

P.E.A.R.'s research shows that when left alone, an REG (Random Event Generator) will produce roughly

one anomalous bit per billion. However, when an operator is present, the ratio increases dramatically to one bit per thousand. This is not enough to win roulette in Vegas, but the importance of the P.E.A.R. data is much more profound than a simple gambling scheme. In fact, the subtle effect that the PEAR data map may be akin to a vast wave of resonance pulsing through the universe, tying not only us, but also our machine into a web of consciousness with capital C. We may be much more closely related to the machines of our making than we ever thought possible.

The QXCI has found a way to maximize the consciousness interface effect with subspace technology.

New Peridyne

There is an undeniable new Peridyne developing in science. The theories of consciousness, quantum theory, subspace systems, fractals, energetic medicine are all being used more and more. These systems will be common place in a short time as people everywhere are losing their fixation on Newtonian dynamics and replication. Society is broadening its mind to more open consciousness ideas. Towards this end some will reject new open minded ideas because they threaten their own ego. If their education was fixated on old now rejected dogmas, they might seek to validate their ego by threatening new concepts. Other will reject the new Peridyne because it threatens their income, if they get money for using the old antiquated system. But we encourage you to have the vision and determinism to see the future of energetic medicine. And network with us if you need help in this new vista of medicine.

The science behind this entire field of energetic medicine may seem foreign a first. The newness of these thoughts and the resistance of the old order have made the spread of these new ideas slow. These ideas seem so complex and ununderstandable. Just as the concept of electromagnetic radiation and television seemed some years ago. But now we all understand the simple ideas of television. We don't have to know all of the science to use a television, nor do you need to know all of the science to use the QXCI.

First here is a quote from the most authoritative English language source on the Tibetan Buddhist Terma (Treasure) Tradition. The "Treasure Finder" is called the Terton and may be either male (usually) or female. (Garnet Dupris actually sent me a copy of this book last year with many important areas hi-lighted.) Anyway here's the quote from page 82-84-the book is filled with much more Terma related information.

Support or consort

"Most Tertons, except a very few such as Padma Wang Gi Gyal po (1487-1542) and Ja Nying po (1585-1656) who were celibate monks, have been followers of Tantric discipline. They remained in the household life with consorts, children and possession. For them the household life is a method of practice to transform every source of experience in life as the means of enlightened attainment. Its purpose is not the enjoyment of sensory objects.

The support of a consort has two purposes. First, through Tantric training it helps to produce and maintain the wisdom of the union of a great bliss and emptiness, by which the adept attains the ultimate state. Second, a realized person who has the requisite powerful aspirations takes birth as the consort of a Terton in order to fulfill the mission of discovering the profound esoteric teachings for the fortunate followers. For the Terma tradition a consort is a very important instrument. Through the auspicious

circumstances of generating the wisdom of the union of bliss and emptiness or freedom in the Terton's mind, the consort causes him or her to awaken. The realization as well as to discover the Termas. Wander Ocean says:

"...by encountering the miraculous skill of a Vajradula [consort] whose mind has been purified by empowerment and precepts, who has practiced the path of two stages, has been purified by empowerment and precept, who has practiced the path of two stages, has been blessed by Guru Rinpoche himself to take birth in the future as a sacred support [consort], so that by the hook of a spontaneously arisen bliss a Terton who has made appropriate aspiration may discover the Termas of the sphere of primordial wisdom."

Since the functioning of all existent phenomena depends on their positive causes and condition, if the right consort cannot support the Terton, the discovery might become impossible or very difficult, like growing flowers without heat. Then even the Terton's life is threatened. For in most cases the purpose of a Terton's life is to discover the teaching for fortunate beings. The great Terton Padma

Ledrel tsal (1291?-1315?) did discover his Terma, but because he couldn't meet the right consort he died soon afterwards, before he could propagate it.

In his autobiography Dudjom Lingpa said that he could not get the complete Terma from Nga la Tangtse because he did not have a consort with him at the time.

Sometimes for the discovery of several major scriptures by the same person, the support of different consorts is required because of their specific aspirations for discoveries at the time of concealment. There was even a Terton who was young and who had to have the support of a woman who was in her eighties and was crippled. She had to be carried to the place of discovery to perform the ceremony since, owing to past karma and aspirations, her presence was essential. If the right person could not become the consort or be present, sometimes the gift of an ornament or a dress of the person can be a substitute. Because of interdependent causation, the substitute object becomes the support of the discover, decoding of the symbolic script and a propagation of the teachings.

"Both ancient spiritual tradition and modern scientific research recognize that the positive benefits of work with subspace dynamics and digital devices is improved when the main practitioner receives the "support" of an appropriate second individual. This partnership allows for empathy and intention to balance and enhance each other. Results are dramatically improved when the more feminine empathy joins with the more masculine intention. In the SUPPORT FACULTY, enter the name of a person that you feel will best complement your nature. Traditionally, a male would choose the person, regardless of gender, that you feel will give you the best "support". A bond of love makes for excellent "support". Your Faculty should have male and female influence and advisors."

Add Names to Faculty

CE EVOKED POTENTIAL

and the European TVEP QQC

(both patented and trademarked)

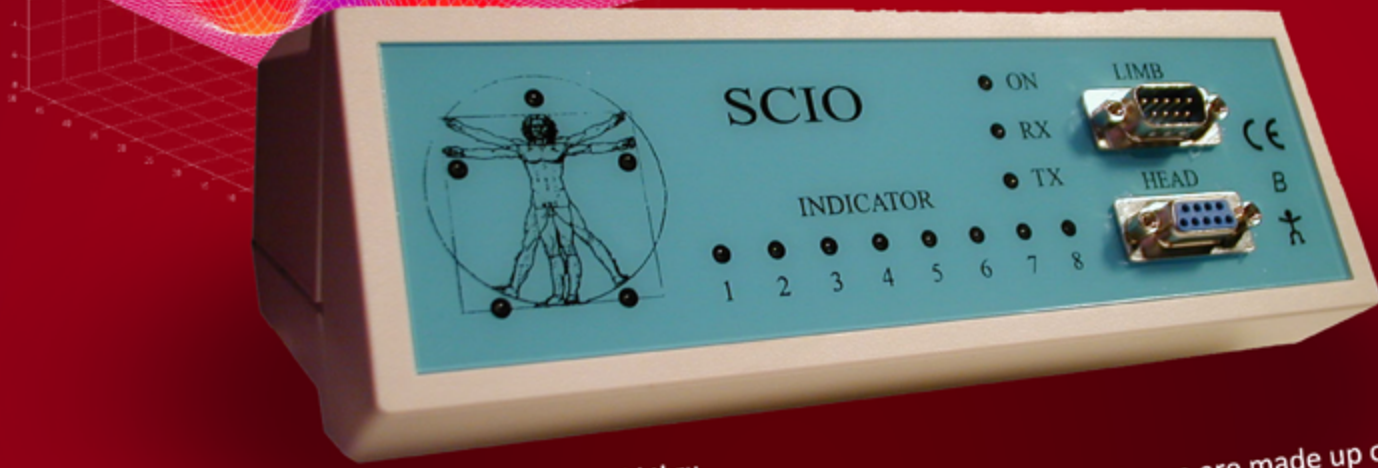

The QQC trivector device passes a changing low level field thru the item and generates a sophisticated picture of the electrical field of the item. It makes a 22X22X22 3D field that means over 10,000 separate frequencies to make one pattern. The shark senses these fields and they are amplified by the salt water. This study leads to the discovery of the electro-sense. Researchers have found that humans also have such a system but it is weak. Every item has such a field. Living things have a changing reactive field, non-living things have a static field non-changing. We now know that the electro-sense in humans is the surface of the skin and most concentrated in the sense of smell. So by measuring the Voltammetric electrical field of items and then amplifying the field 10 million times we get to really measure the patient's reaction to items, really. So by applying a trivector Voltammetric pattern we can measure the response or evoked potential and see the patient's reactivity. So 5 million dollars were spent buying and procuring the items in the matrix and testing these items with a patented registered technology of modern science. This is why the SCIO device works so well, at each treatment from calibration, test etc these QQC signatures are at the heart. Real science, real technology, real legal compliance, real items, real results, real honesty and integrity.

In 5th grade we were taught we are made up of atoms made of electrons and protons and neutrons. The electrons in the outer level are so charged they never touch. We are made of electrical fields.

The QQC is a very advanced patented trademarked technology with a CE mark. It measures in a very sophisticated process the Voltammetric electrical field of any item. If you look up voltammetry in Google you see thousands of references for a world recognized very scientific chemical process also referred to as Polography. You can see our patented process at <http://www.voltametriaqqc.ro/>

Shark Senses

Mary Ann Badavi & Stephanie Parker



Electricity

- A shark's ampullae of Lorenzini are able to feel electric currents at short ranges.
- All living things emit a small electrical current, a shark can feel it from 0-8 Hz.



■ The bonnethead shark has an electrosense that is five million times greater than the electrosense of humans. Picture: Andy Murch/Elasmodiver.com

■ It is also thought that the Hammerhead shark evolved its head to increase surface area for electrical reception.

If you need more information on the SCIO and purchase details please get in touch with us

Maitreya Kft.
 tel: +3613036043
 web: www.qxsubspace.com
 e-mail: info@qxsubspace.com

Subspace Treatise
 on the Collective Unconscious of the Universe

As you choose a faculty to help with your device, let me volunteer to help if you need someone. If you need a male feel free to use Prof. William Nelson, for a female feel free to use Desiré Dubounet. Both are powerful subspace healers to help in subtle ways to improve your device.

William Nelson + Desiré Dubounet

Summary

1. We understand that consciousness has profound effects on biology, and thus, medicine.
2. For our understanding of a medical intervention we must have a system that allows for the development of a consciousness type medicine.
3. In this chapter we offer a mathematical formula to calculate the force of consciousness. It must be pointed out that this force of consciousness and its effect on medicine is not a highly-replicable event. It occurs in almost random, fractal or chaotic terms. However, it does definitely have an effect.
4. This consciousness medicine should not be the only intervention used by a practitioner. We still must be concerned with the physical body, nutrition, emotional stability, structural stability, environment, social nature, and all other ramifications. Consciousness will now become part of our medical regime.

Basic Subspace

Years ago on a PBS NOVA special, an investigation was performed to study the phenomenon of psychic perception. During their account of the research and various experiences in psychic phenomena they explored many different research models, and came up with skeptical viewpoints on the validity of these findings. There was one experiment, however, that even NOVA and the team of researchers found impossible to dismiss. This experiment was duplicated by the engineering departments of nineteen major universities, not by the psychology or parapsychology departments. The experiment proceeded as such:

A piece of radioactive material was placed next to a Geiger counter, which would count the emission rate of various particles. It is known that the emission rate of particles from the radioactive material are at an indeterminate rate, falling under the indeterminacy equation. This means that the material is decaying, and when the next ray will be emitted is indeterminate. We only have a construct of probability. We have no technology or ability to calculate exactly when the next ray will be emitted. First they would determine statistically the probability of the time the next ray would be emitted. This probability was then calculated by a machine. A computer was hooked up to the Geiger counter, which in turn was hooked up to a clock in another room. If the ray coming out of the radioactive material came out at the same probability that was statistically measured, then the clock would not move. If the ray came out of the radioactive material in under this amount of time, then the clock would move one second counterclockwise. If the ray came out in over this amount of time, then the ray would cause the computer to move one second clockwise. Thus if the ray came out as predicted statistically, it would produce no movement on the clock; if it took longer, it would produce a clockwise movement; if it took less time, it



PROOF of NON LOCAL UNIVERSE

The Big Bang Theory States that the entire Universe poured through a singularity in a flash. Ten to ten minus 43 of a sec approximately. There is a left over echo of a Cosmic Microwave Radiation that reverberates throughout the Universe.

Quantum theory tells us that particles that have shared a common quantum connection retain the ability to communicate.

Two twin photons separated to the ends of the universe share info. What is told to one is instantly aware by the other photon. The photons and neutrons were made into electrons and protons. These congealed into the stars. Inside the star the incredible energy made all of the other elements. The stars collapsed and exploded making planets. This shift particles has produced some separation from the entangled quantic origin. But the Cosmic Microwave Radiation is still entangled.

The world and the universe have been bathed in the cosmic radiation for over 13 billion years. Thus there is a quantic link of all information of life.

Subspace Treatise
on the Collective Unconscious of the Universe

would produce a counterclockwise movement. When the clock was allowed to run without the presence of human subjects, the movement of the clock would statistically hover, by moving sometimes forward, sometimes back, but usually around the mean. Experimenters then had subjects step into the room with the clock, unaware of the other processes of the Geiger counter or the radioactive material which were hidden in another room. The subjects in the room with the clock were asked to make the clock move clockwise with their minds; the only instruction given to them.

To the mystification of these engineering departments, as well as NOVA, most could move the clock clockwise with their minds. Others, as hard as they would try to move the clock clockwise, would move it counterclockwise. But almost everybody had an effect on the clock beyond just chance. The experimenters found a gender variance in the study, with males causing more counterclockwise than females. Some how the human mind could effect indeterminacy of a specified operation without conscious knowledge of the process. In the gross world of thermodynamic physics objects have predictable outcomes. To build a set of brake pads for a car experiments can be developed with consistent outcomes. There is no need for double blind experiments on the thermodynamic brake pads. certain materials pass certain don't and thinking dos'nt change the results.

But when scientist started smaller and smaller experiments there came a size where suddenly the thoughts of the observer effect the outcome. Quantic experiments of any size were effected by the observer and 'the observer effect' was born.

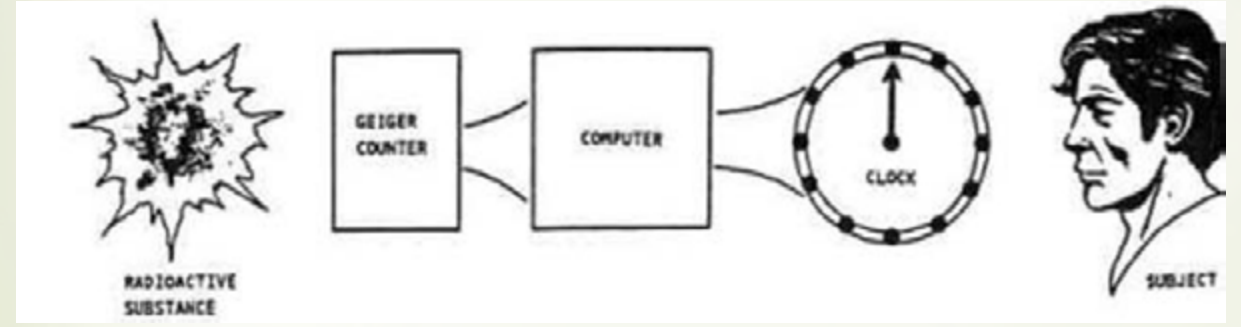

Many scientists struggled with the observer effect and try to rationalize it away. But suddenly physics had to design double blind experiments to counter the effects. Biology was faced with the same dilemma. There was definite experimenter effects in living systems experimnets. So the double blind experiment was designed. The thought was that experimenter bias and shifting of data was the reason, this is indeed true. But what if there was a more significant reason? What if the conscious mind could effect the outcome of an indeterminant situation under quantic rules?

What if Biology was under quantic rules and as such responded to thought? We hold as a treatise that biology exists because of its indeterminacy, and we further expound that indeterminacy can be shaped by the human brain.1 This shaping or effect of one quantic system on another at an indeterminant level, could be happening through some subspace dimension. Topology defines subspace as an infinite set of spaces existing inside, beneath awareness, and enclosing other space sets. Thus our thought and mind is aware of a 4 dimensional space of our conscious mind but there are definitely subspace dimensions existing beneath our awareness. There are parts of the brain that appear to act as transmitters and receiver for subspace transfer. This is referred to as the psychic abilities of man and animals, or the

radionic capacities. The dynamics of this principle are threatening to many scientist.

Every culture known to man has developed indeterminate methods of analyzing its future. The ancient Norse would throw antler horns into the fire and watch the cracks that might appear, to determine where they might find the best hunting. Some cultures used tea leaves. The Chinese used the Yarrow sticks, as well as the coins to throw the I Ching. The Celts developed the Tarot cards. There are many other examples. The human mind has found that it can shape indeterminacy, and that indeterminate events can provide intriguing consultations to the human experience. The indeterminacy of an atom was explored in this experiment, but there is a greater indeterminacy in biology, which accounts for the possibility of human beings to interact and experience their environment.

Mathematicians and scientists agree on the existence of other dimensions often referred to as subspace. These subspace dimensions are not apparent to the verbal conscious mind but might be accessible to the dream state. In the dream state events can occur out of time cause and effect relations and the laws of time and space are more variable. There are at least 10 subspace dimensions existing beneath our awareness. These dimensions are connected with the overall consciousness of the unified field of the universe.

Intercommunications between dimensions is a basic postulate of our subspace biology. Much later in this book we discuss the subspace in more intimate detail. But now we must accept the postulate as a possible explanation of the ability of a conscious system to influence an indeterminate state at a distance.

Since the effect is on the indeterminacy of a system the effect would be subtle, irreproducible, and complex. Modern reductionistic and reproducible science would have trouble with such a system. But modern mathematic could embrace such a system.

So there is a constant struggle between indeterminate science and determinate science. Indeterminate sciences have been looked on as metaphysical sciences; whereas the determinate sciences have led to discoveries of engineering, physics and chemistry. Each one, through its own fallacy of philosophy has thought that it is superior to the others, but a true look at biology in the human experience and the development of science will tell us that some culmination or blending of these two mediums is important. Many researchers have developed ways of looking at determinate events, such as Boyle, who developed gas laws for analysis of the determinate events within a gas. This led to the discovery of the laws of thermodynamics.

The zeroeth law of thermodynamics is that temperature exists. The first law of thermodynamics is that energy cannot be created or destroyed.

The second law of thermodynamics is that heat must pass from a hot body to a cold body; a cup of hot coffee in a room gives temperature to the cold room, both being non-alive (the definition of life for an object being that it must be able to metabolize and reproduce on its own). Eventually the two will come to equilibrium, as the process of thermodynamics dictates in the second law. Yet, a human being sitting in the same room will give heat to the room but will not lose temperature; he will maintain 98.6°.

As the third law of thermodynamics encounters, we can maneuver things through steps. Brown was a researcher who long ago found that when he put pollen cells under a microscope, he could detect subtle movement; this was then labeled Brownian motion. This Brownian motion was later found to

be the entropic shifting of the molecules that happens in gasses, solids and liquids. Entropic shifting is like millions of billiard balls in a box; if one knew the position of the billiard balls and their mass and momentum, one would substantially know the system. This is determinism. Thus, a hotter molecule, when striking a colder molecule, transmits an amount of momentum. Conservation of momentum is maintained.

The oxygen in the room's air is thermodynamic, moving back and forth, obeying the gas laws, being bombarded. But as it is taken into the human nostril and crosses the alveoli barrier of the lungs, it loses its randomness. Once inside the red blood cell, it now becomes indeterminate, nonthermodynamic, and quantic(controlled) in its action as it obeys a bio-quantic control within the cell. Within the cell we do not find Brownian motion; we find a controlled process. So random entropy is not a factor of life; it is a factor of death. The laws of thermodynamics are the laws of death. Life cannot exist by random thermodynamics. Some type of molecular control is essential for life to exist. Life must have some mathematical process control over the system. We are alive because of our fight against the laws of thermodynamics. If the cell should die; as we watched the molecules within, we would see that they would start to slip into Brownian motion.

They would start to obey the laws of thermodynamics more fully and would lose their fight against the temperature of the room and gravitate to equilibrium. In the words of the Washington Posts editor when a person dies he loses his fight against room temperature.

Thus, the testing of any type of biological entity in vitro (inside the test tube) is vastly different from the results one might attain when looking at it in vivo. As Heisenberg speculated, even if we tried to do in vivo testing by measuring something so small, we would interfere with the process, and thereby not know the process. We have a medicine built around tracer elements that basically tells us very little about true biology. What happens to radioactive iodine in the body is that it apparently gravitates toward the thyroid. All that we know from this experiment is that radioactive iodine goes to the thyroid. We do not know where real iodine goes, because we have interfered with the process by using radioactive iodine, just as if we were to take a student in a room and cover him with a tracer such as horse manure, we would be able to find him with our noses whenever we needed him. We would have a tracer. We would observe that during the day this person would go to bath houses and perfume shops, and we would think that those were the natural events of his day. A radioactive molecule such as iodine is recognized by the cells; cells are able to see this radioactive molecule shooting out rays, and radioactive tracers are treated differently by the cells. So we do not know where real iodine goes, or real sodium. To really know the process of biology will always be indeterminately impossible, because we can only measure what we have interfered with. Only nature can know biology. This leads one to further believe and acknowledge that the natural process knows; the synthetic process (intentionally spelled this way throughout the book, from here on) does not know, and that one can never arrive at biology through synthetics. Thus, in the development of a medicine we must look at the natural process and the naturally occurring parts of the plants. The Bible tells us that "healing shall come from the leaves of the field". With this type of observation we can develop a superior medicine. Such a superior medicine is exemplified in naturopathy and homeopathy, which offer to mankind tremendous healing opportunities. But synthetic chemicals have always made more money, and have been rationalized by the amount of science that goes on within the test tube. Yet now, with this quantum physics of biology, perhaps we can see that our test tube

technology has left us high and dry, and synthetics will produce many side effects and iatrogenic diseases.

We have already seen this in our society, as iatrogenic disease has escalated more than any other. In the synthetic world of surgery and pharmaceuticals there are approximately four hundred billion dollars a year sought in malpractice suits; people who became hurt through the concepts of synthetic medicine. Yet, with homeopathy and naturopathy, which are legal entities in the United States and the world, there are less than one thousand dollars in reward suits made every five years.

This drastic difference is concealed by modern medicine in a cover-up like no other. This type of cover-up makes Watergate seem trivial. Rupert Sheldrake postulated on this indeterminism. Carl Jung discovered the principle of synchronicity: human existence is full of different types of unexplained indeterminate events, which point to a new concept of reality. This transfer of consciousness or synchronicity would be through some subspace dimension and obey quantic rules of observer effect. The shared consciousness of all things in this single universe could communicate on some level of shape transfer across these subspace channels. This would make them independent of the space and time restrictions of our current limited space. The effect of consciousness transfer through subspace channels to effect quantic systems at a distance has been called the 'Nelson effect'. Sheldrake, who wrote the book on "Morphic Resonance", postulated that this indeterminacy could be shaped by a large indeterminate series of events. Such an event, he thought, was the group of synapses within the human brain, and that if a large series of indeterminate events could capture the same numbers as the indeterminacy of the human brain, this would allow for that process to duplicate in some manner the thought process of the human brain. The number of synapses in the human brain has been postulated as 1013. The amount of possible interactions is 10 to the 23rd. If a machine could be made to do indeterminacy at 1023, that indeterminate event could be shaped by the human brain. The subspace reception of the human brain could be duplicated.

Such a machine has been developed by the Ecllosion Corporation and is known as the Xrroid. By generating 1023 random numbers, these events can be used to generate speech quality and to generate artificial intelligence through an indeterminate process rather than a determinate one. Most computers work on a binary system; On/Off, 0 or 1. This computer system works on the trinary logic of On, Off, or Indeterminate. This indeterminacy is shaped by 1023, allowing for a computer to much better approximate the human brain. This trinary logic system has been used to develop medical protocols and artificial thought processes. A quatern system has even been proposed of on off in determinant and don't care. Development of the trinary logic system represents a tremendous achievement, going beyond the binary system to a more human, trinary, indeterminate system; yet, this step must be taken with great caution. If we truly had a computer that did think like a human, the threat to our society could be awesome. Thus these discoveries and technologies should be left in the hands of scientists who are not looking for profit motivation, but are rather looking to help mankind to grow in awareness, and through a reverence of nature, rather than a synthetic demise of it.

The precept of quantum physics allows for a particle to be in two positions or places at the same time. This is a dramatic shift from the idea of classical physics.

The phenomenon of tunnelling also occurs in quantum physics, wherein a proceeding particle can suddenly skip through time and space, or through other barriers, and appear on the other side. This type of phenomenon is impossible according to classical physics. Some people have labelled this phenomenon,

known as the Nelson effect, also applies to the human brain, and may be a major factor in NOVA's clock experiment.

Plato developed a concept of the world of 'FORMS'. He proposed that there was a world of ideal forms that existed and effected everything. There was in this world an ideal dog, cat, persons, rocks and all things as ideal or perfect forms. Then in the real world there was imperfect attempts of these forms. This is understandable in our new physics as a subspace dimension existing beneath this dimension, effecting all things. This subspace dimension can also explain our polymorphic shape transfer of Morphic Resonance. Reviewing Plato's world of forms in the light of our new physics demonstrates his vision and genius. This shows how even long ago another dimension of shapes was anticipated.

In light of our subspace theory, philosophy and science hold hands again.

Another exciting concept that further validates our concept of morphic subspace is the healing power of prayer. Over 270 studies on prayer in a clinical setting have dramatically shown that patients who are prayed for have significant improvements in health compared with those that do not. Larry Dorsey's book 'Healing Words' by Harpers 1993, covers this phenomena from a Medical Clinical perspective.

The minds of the people praying can effect the bodies of those needing healing in a fashion that defies time and space rules of a 4 dimensional physics. The prayers are a communication through the god consciousness which is partially our subspace morphic tunnelling through barriers phenomenon as leapfrogging, or an insertion of extra energy within the Heisenberg uncertainty principle, and its ability to leap over the energetic barrier. In classic physics if a particle of a certain potential is proceeding and incurs a barrier of lesser potential, the particle can cross the barrier. The motion of the particle becomes slower during the crossing of the barrier because of the involvement of the different energies. By generating a quantic indeterminacy field interfaced with a human unconscious field a larger scale tunneling phenomena is possible, even possible for humans even thru time) resonance. This allows for a polymorphic influence over the indeterminacy of the targeted system. This scientific description of a religious process is not meant in any fashion to be demeaning instead it is meant to be fulfilling. As we stated in the preface and introduction, science must join with mysticism and religion. A new science should result without the anal retentive cling to reproducibility. Quantum physics has a least taught us that.

So in summary, there is a subspace set or sets pervading and connecting the universe. There appears to be a unified field uniting all space sets. At least one level of this field is an expression of universal consciousness. There is a pathway to interaction of directed thought consciousness possible through this subspace connection. Thus a conscious quantic system can effect another through interaction via subspace.

This phenomena follows quantic rules and is thus non reproducible, non reductionistic, subtle effecting in determinant systems by shifting probabilities, among others that we will investigate.

When Bell Theorem was proved, it showed that there was a connectivity in the universe that transcended time and space. The connect ion of dual or twin quarks is instantaneous across the universe. This proves the existence of our subspace where things still all act as one.

Einstein once said that the universe is on thing. It is an illusion that we appear separate. It is our job as humans to transcend the illusion and increase our circle of compassion till it includes all things.

The proof of subspace offers us a dilemma. If there is a subspace (and there is), If we can communicate thru it (and we can), then advanced societies might have dropped using old fashioned EMR (ElectroMagnetic Radiation) or Radio, and they might be using Subspace. Then our large dish receivers might be tuned to the wrong frequency.

Subspace is tied to the indeterminacy matrix and is quantic in nature. It is akin to a God consciousness and has a powerful right brain or female component. As such it is difficult for our left brained control everything scientist's to accept fully. The mental rigidity of these persons has no bounds, even when faced with the coming of fractal theory they cling to repeatability for security.

When Prof. Nelson accepted the right brain female side as equal, the precepts of subspace were let out of the box. Only in this case they will put famine, war, and pesticides away. This is Pandora's box in reverse.

Summary

1. *Quantic Indeterminacy is a basic fact of biology.*
2. *The human mind can influence the indeterminacy of the cell or of other quantic systems. In fact the human mind can influence anything.*
3. *The Nelson effect is the term we use to classify the effect on the indeterminacy of the mind. This might be explained through the extension of the tunneling phenomenon of quantum physics.*
4. *Every culture has known and used this uncertainty for advice and knowledge. And every culture has observed and used directed thought as prayer or ritual.*
5. *This subspace effect is nonreproducible, non repeatable, nonlinear, subtle effecting shifts in probability, of consciousness, intensified with directed thought, intensified with positive thought and zeal.*
6. *Attempts to explain these indeterminate methods as coincidence have come up short, scientific rejection of quantum theory and of the observer effects have stagnated biology and medicine. See Ref of the Nelson Effect explained In the International Journal of the Medical Science of Homeopathy, issue 6, 1996.*

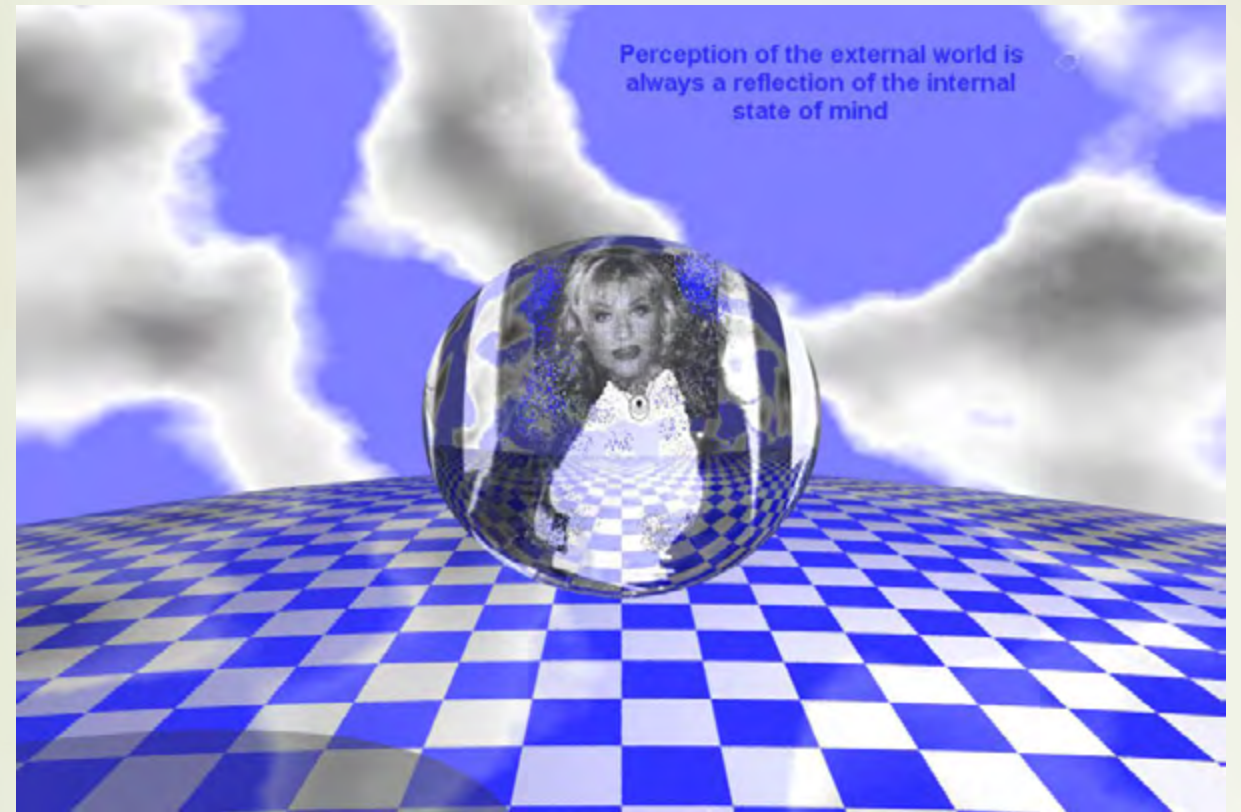

Sacred Geometry of Life

This image of the Flower of Life is not only found in Egypt, but all over the world. It's found in Ireland, Turkey, England, Israel, Egypt, China, Tibet, North and South America, Lapland, Sweden, Iceland, Greece and Japan-it's found everywhere.

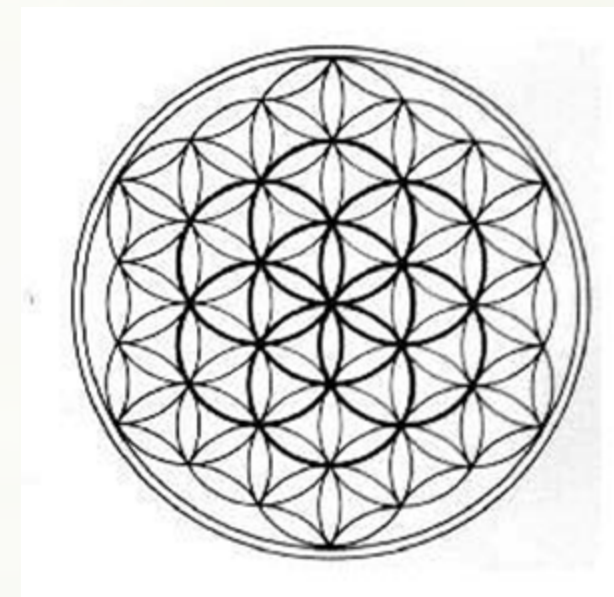

Almost everywhere around the world it has the same name, which is the Flower of Life, though elsewhere around the cosmos it has other names. Two of the main names would be translated as the Language of Silence and the Language of Light. It's the source of all language. It's the primal language of the universe, pure shape and proportion.

It's called a flower, not just because it looks like a flower, but because it represents the cycle of a fruit tree. The fruit tree makes a little flower, which goes through a metamorphosis and turns into a fruit- a cherry or an apple or something. The fruit contains within it the seed, which falls to the ground, then grows into another tree. So there's a cycle of tree to flower to fruit to seed and back to a tree again, in these five steps.

This is an absolute miracle. But you know, it just goes right over our heads. It's so normal that we simply accept it and don't think much about it. The five simple, miraculous steps in this cycle of life actually parallel the geometries of life, which we'll continue to see all through this work. The Seed of Life On the right in a picture, in the middle of the Flower of Life are seven interconnected circles which, if you take them out and draw a circle around them, would create the image called the Seed of Life.

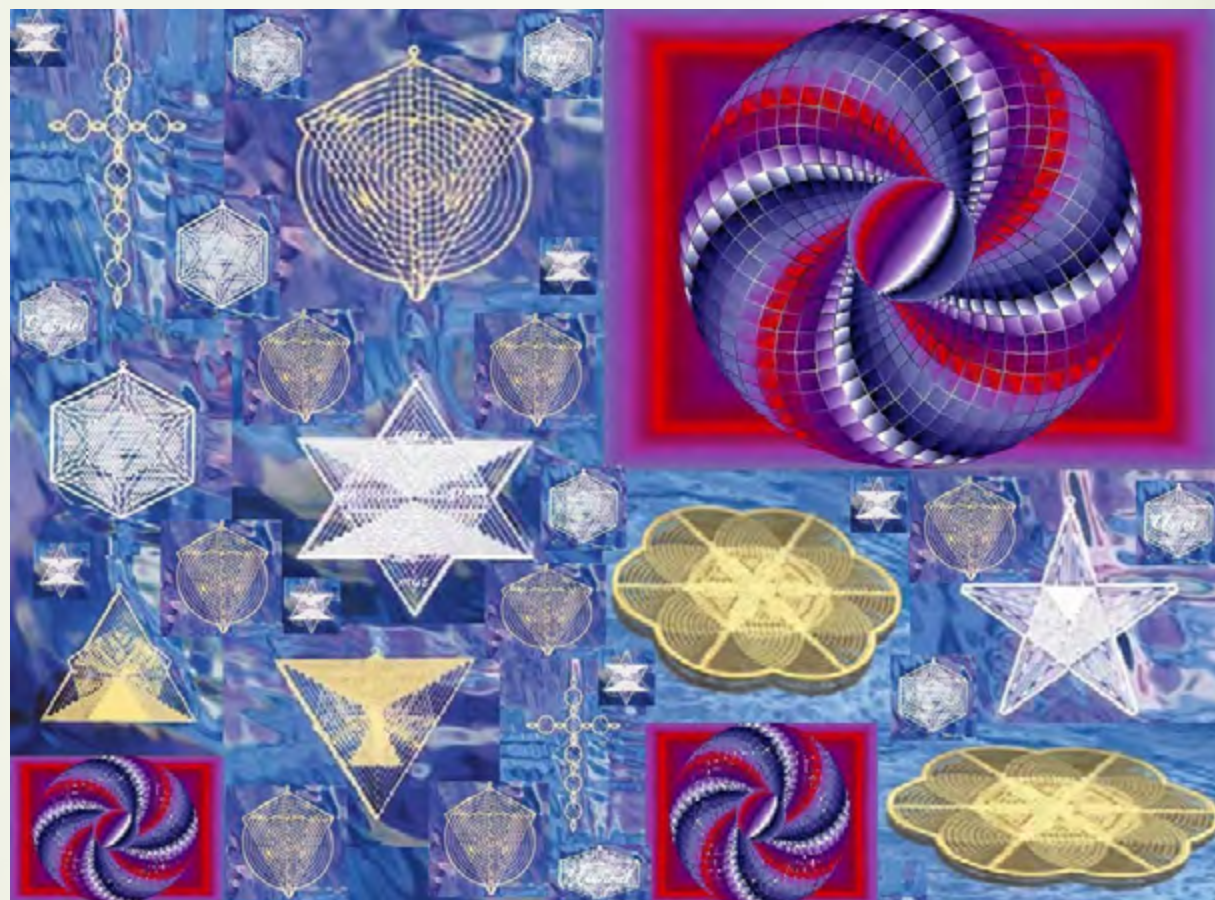

The Tree of Life Connection

Another image in this pattern, which you're probably more familiar with, is called the Tree of Life. Many people have thought that the Tree of Life originated with the Jews or Hebrews, but it did not.

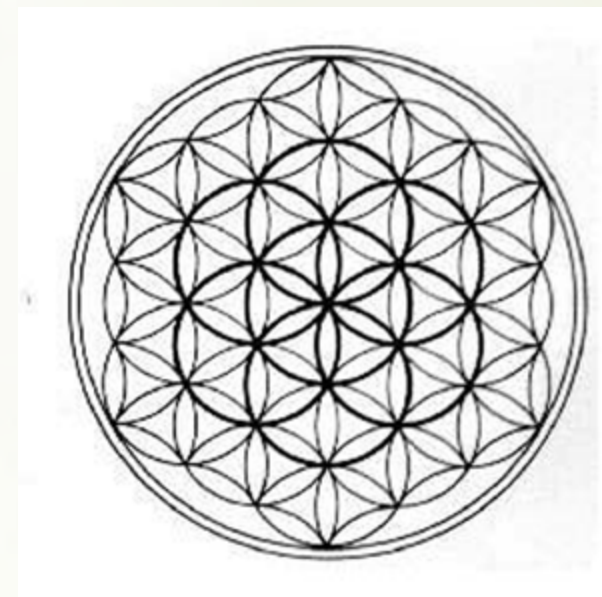

The kabbalah did not originate the Tree of Life, and there is proof. The Tree of Life does not belong to any culture-not even the Egyptians, who carved the Tree of Life on two sets of three pillars in Egypt at both Karnak and Luxor around 5000 years ago. It's outside any race or religion. It is a pattern that is intimately part of nature. If you go to distant planets where there is consciousness, I'm sure you'll find the same image.

So if we have a tree, then a flower, then a seed, and if these geometries do in fact parallel the five cycles of a fruit tree that we see on Earth, then the source of the tree would have to be perfectly contained within the seed. If we take the images of the Seed of Life and the Tree of Life and superimpose them, we can see this relationship.

See how perfectly they fit? They become like a key, one fitting directly over the other. In addition, if you look at the Tree of Life that was found on Egyptian pillars, you'll see one more circle above and one below. This means there were originally twelve components, and the twelve-component version also fits perfectly over the whole Flower of Life image. (There is a thirteenth circle to the Tree that can either be there or not.)

First you should see the synchronicity of the way sacred geometry forms move together and fit perfectly into each other. This is a right-brain way of understanding the special nature of this geometry. As we study more and more complex patterns, you'll keep seeing the same kind of amazing relationships moving through everything. The odds of some of these geometrical relationships happening at all is probably a zillion to one, yet you will consistently see these mind-boggling relationships unfold.

The Vesica Pisces

In sacred geometry there's a pattern that looks like this.

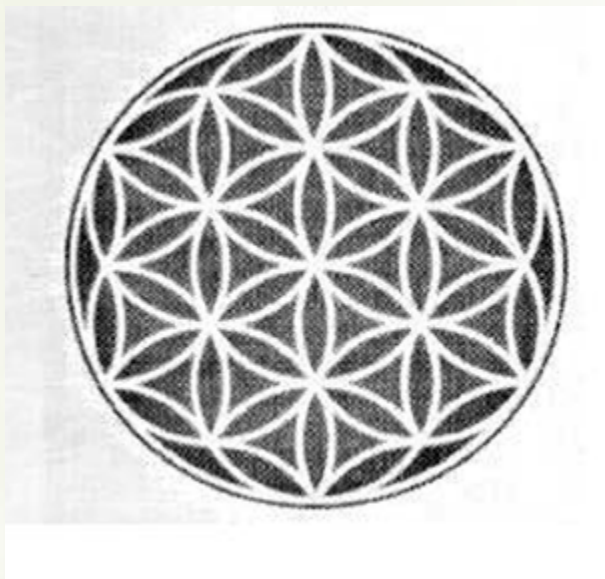

It's formed when the centers of two equal-radius circles are placed on each other's circumferences. The area where the two circles intersect forms what's called a vesica Pisces. This configuration is one of the most predominant and important of all relationships in sacred geometry, as you'll begin to see. There are two measurements in the vesica pisces—one that runs through the center across the narrow width, and one that connects one point to the opposite point through the center—that are keys to a great knowledge within this information.

What many people don't know is that every line in the Tree of Life, whether it has 10 or 12 circles, measures out to either the length or the width of a vesica pisces in the Flower of Life. And they all have Golden Mean proportions. If you look carefully at the super-imposed Tree of Life, you'll see that every line corresponds exactly to either the length or the width of a vesica pisces. This is the first relationship that became visible as we came out of the Great Void.

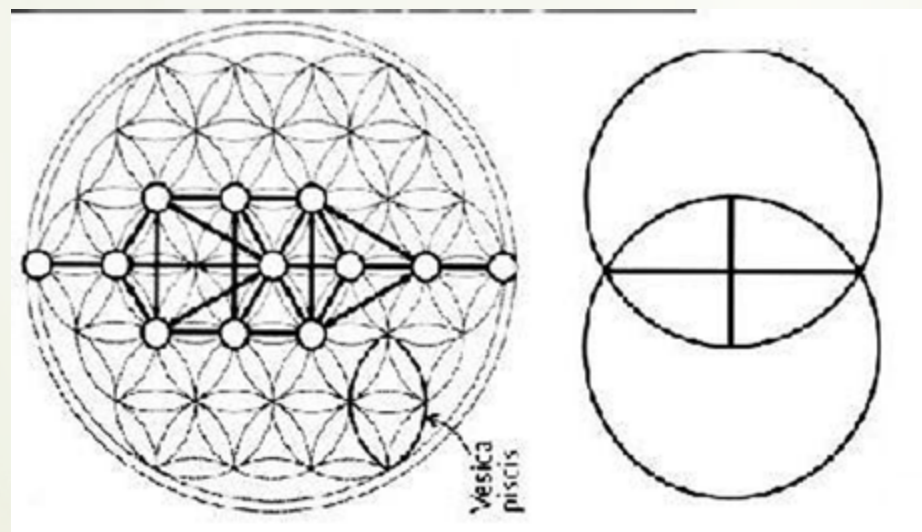

Quantum Biology + Indeterminacy influenced

Biology is not a random event; if it were, the nose might occur in one spot or another on the face; yet, we all have noses in the same spot. We all have ears in the same spot. Biology needs to be controlled, not random. Even the organization of its behavior at the subatomic level must echo the control. The quantic control of cellular function dictates life, not the statistical randomness described in thermodynamics. A restriction of the degrees of freedom of the molecules of life occurs in biology through an electrical process. A volt, amp, and resistance field or a trivector field is imposed by the bio electric capacities of the cells of an organism that control the molecular movement and restrict the molecular degrees of freedom. This allows for the control or organization needed by life over the chemicals that make it. Since this field is of a quantic nature and is thus susceptible to the Nelson effect. The subspace field is the key to the field strength and nature. Subspace allows for transfer of information and shape, and for shape restriction of the motion of the biological molecules. So morphic resonance is a subspace Phenomena. Since subspace is not restricted by time and space, 4 dimensional thinking will not apply. Much of the factors of life are not explained well by such limited thinking.

In fact the size of the complexity of life, the response of life to insurmountable challenge, the quantic nature with its indeterminacy, and the abilities of life to transcend existence bring us to the most outstanding hypothesis of all 'How can some scientists still see life in such reductionistic and limiting terms'. When a man points at the moon some scientists just see the finger. To work with the coil of life and not see it's indeterminacy side or it's magic is sad.

Under the complementarity principle the uncertainty relation may be employed to establish the mechanistic indeterminacy for molecules, in view of the conditions for which biology occurs. Quantum theory is open-ended, and can accommodate a mechanics for quantization of molecular motion. This will allow for a non-deterministic, unexpected quantum explanation for large molecular actions as the basis of the necessary processes in living units.

Of course, the Bohr correspondence rule, under generalized complementarity, places a boundary upon the broader quantum descriptions precisely by limiting conditions in which statistical mechanics are appropriate.

First we must understand fundamental theory. Physical theory is concerned most fundamentally with the motions of bodies and interactions of the motions of bodies. This is to say that descriptions of physical processes are concerned with, or can be reduced to, a description of mechanical action of mass or energy transport in space and time in correspondence with the laws of motion.

Newton, in the development of calculus, laid out an interaction for understanding larger real world events in terms of breaking them down through calculus into very small units. He then approximated the integral of the acceleration, or by reversal, calculated the differential of the equation. Thus Newton saw the need for breaking into small parts the movement of different items in the real world. His approximation of the calculus was indeed a step in the direction of quantic theory, because it now allows for the idea of a noncontinuous process, the idea of a specific jump or collection of different readings that would make the calculations function.

It should be pointed out that Newton's observation was of statistical events, following classical physics

and outlines. He interpolated the connections in developing calculus. This is a phenomenal achievement in mathematics and science that has allowed for tremendous understandings. However, applying calculus to biological events inside the cell or the organism has always come up on shaky ground.

There are over 100 Billion Neurons in the Brain

The Brain receives Photonic, Electrical, Chemical Information from all of the cells of the body to Regulate all of the Body Processes

But the Reticular Activating System (RAS Word Brain) can only handle 1 million bits of Data a second or it is overloaded

This means there is 10 to the 18th bits of information going to the brain every second,

So the word area is getting one percent of one percent of one percent of one percent of one percent of one percent of one percent of one percent of one percent of the information of life.

The Rest is going to the Body Electric.

With the DNA of 100 Trillion cells sending information to all of the Brain, It is an Overwhelming task of the Body Electric.

There are approximately 10,000 cellular Operations Happening every second

DNA use photons and electro-magnetic static effects to transfer information

In the events that Newton observed and measured, watching falling and moving objects and developing calculus, he was looking at a determinate, statistical process of dead interaction; he didn't look inside the cellular metabolism, where he probably would have found a different type of organization.

In dealing with the laws of motion, Newton had the luxury of dealing in the macro world, where he could measure his conjugate variables, such as mass and motion. Accordingly, he would be able to calculate momentum. As we move down into smaller and smaller events, eventually we bump into the Heisenberg uncertainty principle, which tells us that we can no longer know both of these conjugate variables at the same time.

We will be unsure of position, or unsure of movement, but we will not know all of these variables, because of uncertainty.

O2 in room air can be charted via closed statistical dynamics. It obeys Boyle's gas laws.

cell phones do affect the brain

the shields can help a little BUT

SCIO



The SCIO can undo the damage by regulating and balancing the Body Electric's Regulatory Processes + increasing VARHOP

If you need more information on the SCIO and purchase details please get in touch with us

Maitreya Kft.

tel: +3613036043 | web: www.qxsubspace.com | e-mail: info@qxsubspace.com

Newton's Calculus

*Change in Velocity
Equal Acceleration*

Several approximations of increasingly smaller steps led to calculus

Uncertainty of Position \times Uncertainty of Momentum = Planck's Constant

The Bohr correspondence rule dictates a place where these events will change from a macro ability to a subatomic process, where we will lose the ability to accurately measure. This is also set out in the Heisenberg uncertainty principle. When measurement does interfere significantly with the measurement of the conjugate variables, then we are at the point where the process becomes indeterminate. This happens in the values of life, because to truly measure and observe intercellular phenomena would be to severely interfere with the process, and thereby lose our ability to know the details needed to make a predictive system. At the quanta of Planck's constant there is a shift from macro dynamics (statistical grouping) to micro dynamics (indeterminacy).

Another step in the formulation of our fundamental physical theory for biology is to establish a minimum number of general necessary classes of living processes. To call a thing a living unit we must see two criteria: one, that it is able to metabolize on its own; and two, that it is able to reproduce on its own. Thus most viruses are not true living units by our definition, because they cannot reproduce on their own. Some viruses do have DNA, such as the adeno virus. Still, they need help in their reproduction cycles. Life needs to independently:

1. *Metabolize-- widely responsive to environment*
2. *Reproduce-- restricted for small numbers of variance.*

Metabolic processes are radically open or asymmetric regarding mass and energy transport in space and time. Mass, momentum, charge and photons go in and out of the living unit. Reproduction processes are radically recurrent or cyclic. This generates limitations of the number of large molecules of the living units in time and space. Thus metabolism must be open to be able to take advantage of the variety of foods, nutrients, and environmental conditions a living organism needs to provide life. This establishes the need to have different mechanisms of detoxification or excretion of the unused and other excreted units. However, reproduction must be very cyclic. If there is more than one genetic variation for every million potential offspring, then the biological unit will lose control of its environment. The species will be unable to respond and will have difficulty in interacting with its environment. Reproduction will need to be radically closed.

The third step in the formulation of the fundamental physical theory for biology is to establish a description of the mechanical action of this metabolic and reproductive process in living units. To truly know the biological action, we must deal with electrons, protons, photons and other particles in their interactions. We must know and outline procedures of measurement of both healthy and sick photon electromotive radiation, as well as electron EH pH pressures, electron transport chains, and the flow of nutrients as they come in and out of the body.

Thus in describing this process, which we assume to be indeterminate, we must use a complementarity

principle, since the energy and momentums of our mechanisms must be quantized. The quantum explanation will then be non- dualistic with respect to the classic mechanism.

Thus classic measurements of time, space, length, width and energy can be used to describe some of these phenomena, as long as we realize the quantic probability through the indeterminacy principle, which allows us to describe them but not totally predict them.

Our new biology, the quantum biology, will be one very similar to the new electronics regarding transistor behavior and other electrical quantic processes and electrical currents. Just as in the development of a transistor, we cannot know exactly what is happening in the transistor, but we can use it in a predictive probability state. We can use our new science of quantum biology to develop and hone the theories of life, medicine and biology, knowing full well that any time we try to measure or interfere with this system, we are dealing with an indeterminate system. This means that there will always be probability. Yet, just as in electrical theory, when we know the rules, we can better play the game. As we learn more about the rules of biology in terms of electronic theory, we will learn more about medicine. In terms of a quantum theory, we will learn better control and improve the probability of our interaction or medical intervention.

As long as modern medicine mires in the Newtonian dynamics of thermodynamics and entropy, it will be unaware of biology's rules. So-called modern medicine will not know the interaction, and it will be further mired in trying to relate in vitro to in vivo. The development of medicine has largely been an observation process where phenomenological observations are made of what happens in a certain event. What a compound does to a certain organism at a certain time is cataloged. It is not from any predictive science, where we try to say that "this will happen", but largely through observational phenomena. Without a true idea of the rules of biology, modern medicine and biology can only catalog observations.

In a television set an electron beam is fired at small dots on the back of the image orticons tube. When the electron strikes such a spot, it illuminates the phosphorescent spot and provides the pattern of dots that will convey the picture to the eye. There is indeterminacy in the electron as it flows.

So if the spot at which we are aiming the electron is bigger than the indeterminacy, we can hit it, and thereby the electron is following a principle much akin to statistical mechanics. If, however, the size of the spot gets smaller and smaller, until at one point it is smaller than the indeterminacy of the electron, then it would be indeterminate whether the electron could hit the spot needed, and thus would this be an indeterminate process.

Heisenberg laid down an equation for the understanding of this law. Change in mass times change in position is equal to or greater than Planck's constant.

$$\Delta P \cdot \Delta Q \geq h/2\pi$$

In our biological process of the synaptic cleft of the neural process, we can see that the distance involved is one angstrom (A). The mass is the molecular weight of the neural transmitter. In this case, let us take acetyl choline, with a molecular weight of 200. Knowing the position and mass of these units, we can see that the function of neuronal transport in the synaptic cleft is indeterminate, and falls under indeterminacy (see Bio-Quantum Matrix for full mathematical treatise).

$D = 100 \text{ Angstrom} = 10^{-6} \text{ cm}$

$M = \text{Mass of Neurotransmitter}$

$V = \text{Velocity of Neurotransmitter}$

So if we tried to make a television set with the dots very small, we would be under the laws of indeterminacy, and not statistical mechanics. Thus the same thing is happening at the synaptic cleft. Since this synaptic cleft is an indeterminate process, it would appear to the viewer that synaptic phenomena makes it a random event. It is the theory and the thesis of this book that the human brain, with some type of natural force, a God-consciousness if you would, has control on this indeterminate process and allows for life and biology. (This is reviewed in deeper detail in the chapter on Biology must Walk Plank's Constant), [many of the neurotransmitters are released in amounts that exceed thermodynamics, the best example of our quantic indeterminant transfer is the exchange of GABA. This molecule covers vast distances guided by an unknown energy.]

Micro World of Subatomic Particles

Biological Organos of Life Nonbiological Inorganic of Death

Organization	Guided Indeterminacy	Unguided Indeterminacy
Governed by	Life Principle Organized Indeterminacy	Uncertainty Principle
When Observed	Responds to Observation	Responds to Observation (Mind of Observer)

So the process of the synaptic cleft is not a random thermodynamic process, and thus cannot be understood by a strict chemical analysis. Biological photons, long-range forces, vionic energy transfer and other energetic means will be used in the future to interpret the synaptic transfer. This indeterminacy is a shaped indeterminacy. So we can agree with Albert Einstein's belief that God does not play dice with the universe.

Some type of vionic energy can shape this indeterminacy. Perhaps even through the endorphin transmitters of the brain, there might be some interdimensional shift, allowing some type of wormhole path photons or electrons to pass through. This type of interdimensional wormhole has been proposed by modern physicists, but the smallness of it would perhaps only allow for the transmission of a photon or electron. As we have presented, photons and electrons can interfere or enhance the process of biology.

It is the viewpoint that such a worm hole in and through subspace might be transferable from the endorphin receptors of the brain, as it seems that the endorphin receptors, if blocked, sorely inhibit the ability of the human to enhance other subspace dimensions. Radionic phenomena, which can be seen as existing outside the dimensions of time and space, seem to be blocked by the existence of narkan, an endorphin receptor blocker. Thus the placebo response, radionic phenomena, and other psychic events that exceed time and space might perhaps be explained through the function of the endorphin receptors. By blocking these receptors, we find that there is an impingement on the function.

Perhaps the endorphin receptors allow for this other-dimensional transfer of energy through other dimensional wormhole that can break through time and space.

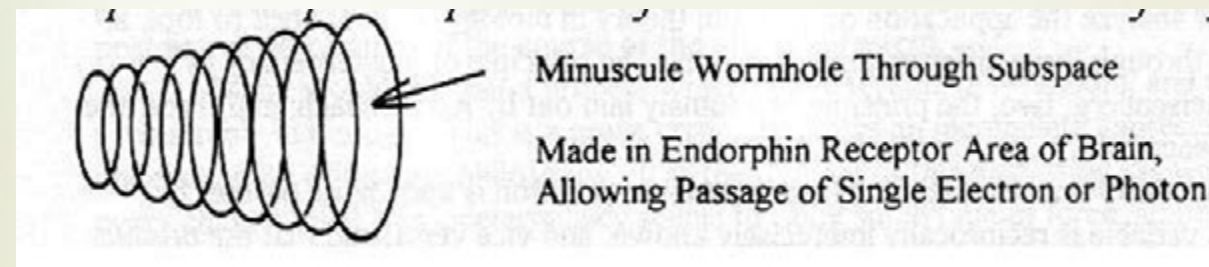

As we develop these abilities, we might be able to master our influence on indeterminacy. Minuscule Wormhole Through Subspace Made in Endorphin Receptor Area of Brain, Allowing Passage of Single Electron or Photon Thus one human brain might communicate with another by shaping the indeterminacy, accounting for the probability that psychic phenomena do have some basis in fact.

The field of psychic interaction has been shown to go beyond statistics and have some degree of probable certainty; not enough for reliability, but enough to disprove a simple Gaussian relationship. So psychic transmission is present, but just enough to tantalize, not enough to rely on. This accounts for the indeterminacy process and the share of morphic resonance.



Perhaps the virtual photon effect will explain how this is still a possible but not extremely probable event.

To further analyze the application of quantum theory in biology, we will need to look at complementarity through three different principles: one, the principle of indeterminacy or uncertainty via Heisenberg; two, the principle of anomaly laid out by Reichenbach; and three, the Bohr correspondence rule.

Complementarity implies that if a dynamic variable of action is known, its partner or conjugate kinetic variable is reciprocally imprecisely known, and vice versa; and that the product of those variables is equal to or greater than the universal law of quantum action, which is Planck's constant, or h . This is a statement of Heisenberg's uncertainty principle, which is not due to a lack of our ability to formulate knowledge or to know, but due to an actual physical boundary, limiting the knowledge we can attain.

- $h = \text{Planck's Constant} = 6.60 \times 10^{-27} \text{ erg sec} = 6.6 \times 10^{-22} \text{ MeV's}$
- $c = \text{Speed of Light} = 2.998 \times 10^{10} \text{ cm/sec} = 2.99 \times 10^{23} \text{ fm/sec}$
- $h \times c = 197.3 \text{ MeVfm} = .1973 \text{ GeVfm}$

Planck's Constant was derived from the speed of light

Reichenbach has pointed out in the principle of anomaly that such a supplementation in the world of phenomena cannot be constructed free from anomalies. As we quote from Reichenbach, "The causal anomalies cannot be removed, because they are inherent in the nature of the physical world. The principle of indeterminacy formulates only one part of this nature. It states that it is impossible to verify certain statements about inner phenomena. To this is added, by the system of quantum theory, another principle we have called the principle of anomaly. It states that no definition of inner phenomena can be given which satisfies the requirement of a normal causality.

It therefore maintains the impossibility of a normal supplementation of the world of phenomena by interpolation."

The correspondence rule of Bohr expresses the fact that as the physical process becomes sufficiently large, a limit is reached at which simultaneous measurement of the conjugate variables can be made with sufficient accuracy for the components to be described by classical mechanics. Thus, the flow of larger quantities of material can fall under macro or Newtonian dynamics, but (as pointed out before) within the vion and the synaptic cleft; and much of the process of biology is happening via quantic or indeterminate action. It satisfies our criteria for indeterminacy. This is definitely happening in the world of RNA and DNA, where the micro-sized material is in the realm of indeterminacy.

Bohr developed the principle of complementarity, which states that our knowledge of a physical system or process is always complementary to the measurement of its state. Bohr said that the word "experiment" refers to a situation in which what has been done and learned can be told to others. He stressed that the account of an experimental arrangement, and the results of the observations, must be expressed in unambiguous language with suitable application of the terminology of classical physics. In classical physics, space-time concepts and the conservation laws of momentum and energy must be utilized simultaneously to make a complete predictive or postdictive description of the course of the physical system.

Many would say that a process which is indeterminate is random, and thus cannot be accountable in biology. This is a grave error. It shows an incomplete appreciation or understanding of quantic philosophy. It is the treatise of this discussion (as we will point out in every chapter) that this indeterminacy seems to obey some type of force, some God-consciousness, some natural process, some inherent wisdom in its own ability to control and regulate the process of biology.

The randomness of entropy and thermodynamics is the law of death. There seems to be some misunderstood, not fully recognized force of life that has not been accounted for in physics to date. It is the treatise of this discussion to open the door for a possible understanding of this phenomenon. Subspace transfer of universal consciousness can explain the control life has on its elements. Again, God does not play dice with the universe.

God could best be described as this universal consciousness that shares its' consciousness with all things. This universal consciousness expresses itself in many different shapes of its' field. The overall factors of its' shape require a multitude of shapes. The Morphic capacities of these shapes are intertwined through the overall subspace and morphic subspace of the universe. The overall effect of this field is felt by all an interpreted in a host of different ways.

God does not play dice with the universe, God is the dice. Time is just one expression of the nature of this field, and its relative nature is expansive.

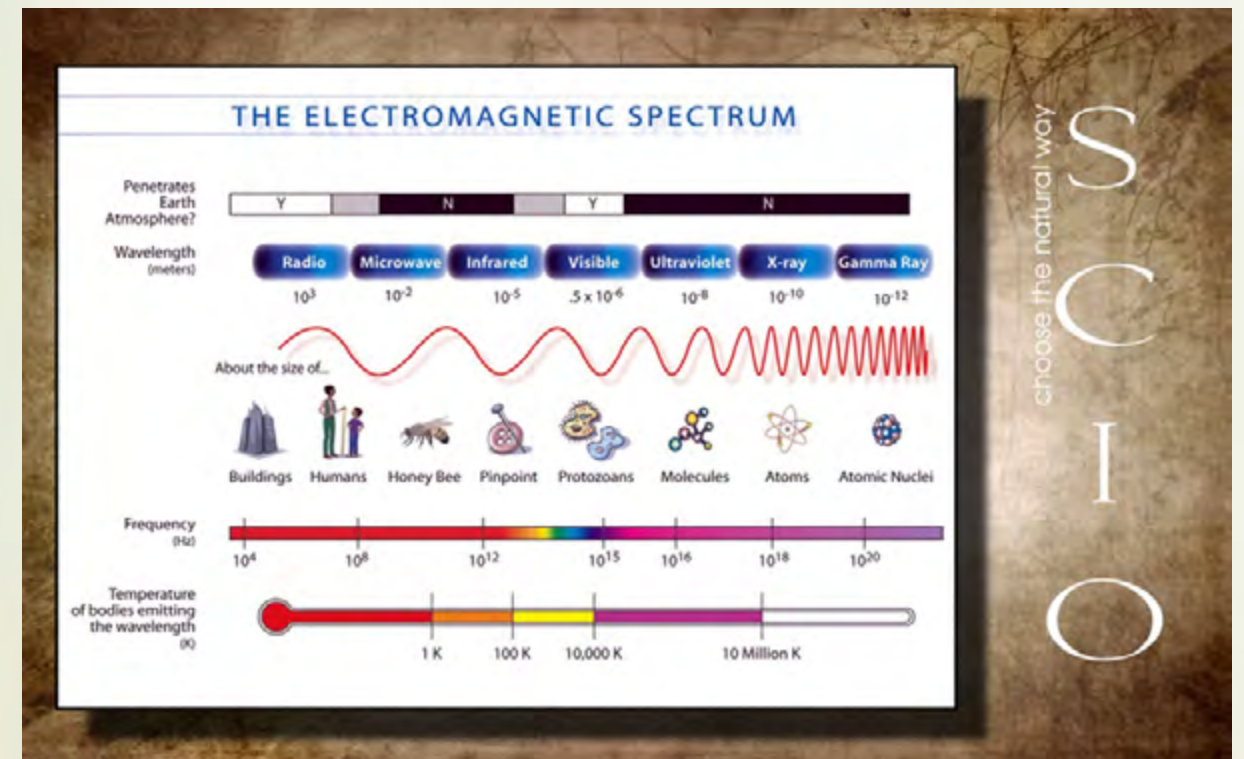

Quantum Physics
Sounds like
Witchcraft
But it
is Science



The field intervenes constantly at quantic levels to affect change through indeterminacy and impose order on the shapes of its members. Much of this shape restriction is thru the Trivector principle. This is an imposition of an electrical field of varying resistance, voltage, and amperage. More on this in the International Journal of the Medical Science of Homeopathy, issue 4.

As Isaacs points out, it cannot be over-stressed that this indeterminacy involves the trajectory of large molecules, whereas indeterminacy then involves phenomenological conditions under which statistically adequate ensembles of particles may be assumed and are usually restricted to the trajectory of electrons and atoms. Bohr's correspondence rule can be stretched under certain circumstances within a quantic system such as biology, which depends on the photo dynamics of the electron interchanges. In nonliving systems, which are not capable of metabolizing or reproducing, the criteria for Newtonian dynamics is fulfilled, because one may measure the conjugate variables of their mechanical action. There are a sufficient number of particles to warrant the Gaussian or statistical dynamics, and there is sufficient or closed transport of mass energy in space and time with respect to the environment.

Predictive perfection was originally expected from statistical dynamics. Fractal dynamics now shows us that nature follows a different set of laws. There is an inborn tendency in matter to follow certain fractal or chaos dynamics. This tendency of matter to follow the fractal patterns then becomes exaggerated, and under quantic conditions life ensues with the ability to metabolize and reproduce.

So we can make a Gaussian statistical distribution from the unequivocal assign ability of the events to disjoint classes of equi-probable events. If there is a sufficient number of events to allow for the calculation, there is sufficiency of the independence of the events relating to the central limit theorem. So if there are a lot of molecules (independent but mutually interactive), and if the system is thermodynamic and follows continuous mathematical relations, these phenomena can be reduced to equation form.

$$\text{Probability} = \frac{1}{\sqrt{2\pi}} e^{-\chi^2/2}$$

χ is measured in standard deviation from the mean.

The indeterminacy equation of Δ position • Δ momentum = Planck's constant (h) over $4 \cdot \pi$. h is $6.6 \cdot 10^{-27}$ ergs per second. This expression is an inequality, meaning that it is greater than or equal to. The uncertainty product must be multiplied by a factor, σ , that would depend on the decision-making process; in nonliving systems σ will approximate 1; in living systems, because of the quantum dynamics, σ will be greater.

$$\Delta(1/n) = \frac{1}{n_2} - \frac{1}{n_1} = \frac{n_1 - n_2}{n_2 n_1} = \frac{\Delta n}{n_2 n_1}$$

$$\Delta(1/n) = \tau \Delta n$$

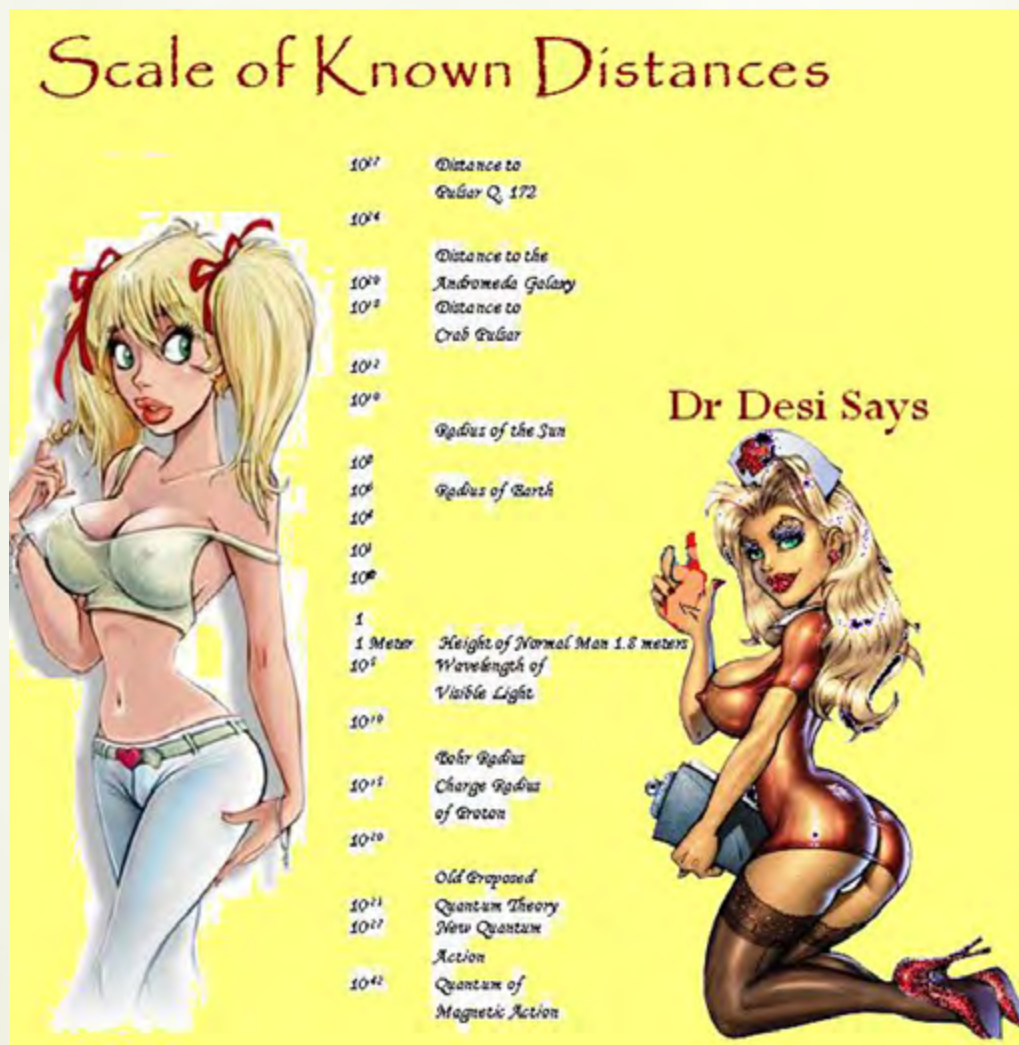

$$P = \frac{1}{\sqrt{2\pi}} e^{-x^2/2} \quad \text{Log both sides}$$

$$L_n P = L_n \frac{1}{\sqrt{2\pi}} - \frac{x^2}{2}$$

$$L_n P$$

$$L_n \frac{1}{\sqrt{2\pi}}$$

$$2L_n \frac{1}{\sqrt{2\pi}} x^2$$

$$\frac{1}{n} \quad \text{Standard Deviation} = B = a/n$$

Processes in which the physical conditions force values of σ greater than 1 in our formula have actions approximately equal to σ times h over 4π . These will have indeterminate bases of operation. The processes that have indeterminate bases must have a quantic feature of their description. This is based on the principle of anomaly developed by Reichenbach. If conditions are right, indeterminacy (thus quantic dynamics) will come into effect. Because of fractal dynamics and chaos theory, we will find that indeterminacy can be satisfied by a number of conditions. The indeterminacy can be enlarged by virtue of three different phenomenological processes:

- A, the number of the molecules can be smaller
- B, the size of the molecules can be larger
- C, the motion of the molecules can be slower

In C, with the motion of the molecules at living temperatures of 98.6°, we find that the molecules are slow enough to be under quantic action, remaining with the temperature of living processes. Room temperature offers a photon (infrared radiation) bath which allows for the virtual photon cascade.

Imposed Limitations on Vions Size

1. Interaction of thermal vibrations of external environment vs. the pull of long-range forces.
2. Reception effect for Mitogenic radiation of 2×10^{15} Hz sets low end of size.
3. Limitation of causality vs. indeterminacy by keeping low number of molecules.
4. Interference of multiple systems sets limits for systems that become too complicated.

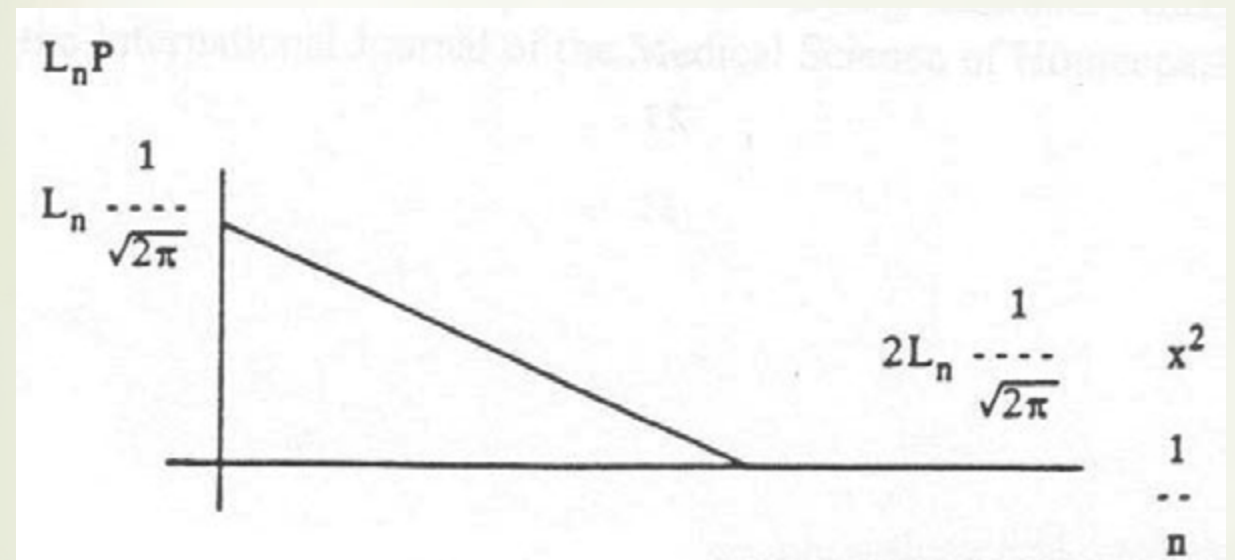

This photon bath makes life possible. If there are too many or too few photons, as when the temperature is too high or too low, then life cannot continue. There are either too many photons, such as high temperatures (110 degrees F. and beyond) or too little (0 degrees Celsius and below). Biology has developed many large molecules to perform its action, and thereby satisfy B. A is satisfied at the cell level by limiting the amount of material that it takes to make a living cell. There is a limit to vion size.

$$3x > 10^5 \text{ cm}$$

It must be pointed out that there are many processes within the body that fall under statistical mechanics and not quantic action. As Isaacs points out, the quantic action takes place within the cell walls. External to the cell walls and the interstitial fluids, as well as the interchanges of gasses and liquids through the body, there are more statistical dynamics following the Henderson-Hasselbach formula, which dictates the pH condition of the body (see Chapter 12).

Thus the management of electron and proton pressure can be statistically thermodynamic in its process, although the regulatory hormonal action of the various cells that regulate this process will fall under quantic control. However, the manipulations of the body to regulate the pH through the pH buffers can be of statistical dynamics. At the cell membrane and surface receptor sites the correspondence rule

allows for a quantic dynamics. Via Bohr's correspondence rule, when we leave the cell we leave quantum dynamics and go into statistical Newtonian dynamics. The human body contains two sets of laws for existence that must cooperate: statistical for extra-cellular, and quantic for intercellular.

Medicine has developed because of an appreciation for the statistical or mechanical aspects of the body, such as the movement and the mass, momentum and energy. As science developed thermodynamic relationships to explain external phenomena in engineering and chemistry, these relationships were supposed to be true of biology, even though these laws could not account for much of the phenomenology of biology. The problem came when medicine tried to take Newtonian and thermodynamic principles of the macro world and body and apply them to intracellular phenomena. The force of it doesn't work.

In a nutshell, we are saying that we should not throw out the advances of modern medicine in regulation of body functions, but that we need to open a door to a deeper understanding involving quantum physics and electronic dynamics, to understand the intercellular phenomena, and to increase our knowledge.

So we have not come to change the laws of medicine, but to fulfill them.

Verhulst Number (FEIGENBAUM)

Hopf proposed a wealth of further instabilities. One such instability involves a jump from point attractor to limit cycle. This is the changing of a torus attractor, such as a three-dimensional system of a torus going to a six-dimensional system torus. A second jump might be a limit cycle transforming onto the surface of a torus. The third type bifurcation might happen if instead of jumping from a two-dimensional surface or torus onto a three-dimensional surface in a four-dimensional space, the torus itself breaks apart, and the surface enters into a fractional dimension. Thus the surface of the torus attractor is actually caught between the dimensions of a plane; two- and three-dimensional. This type of analogy can be seen in trauma cases, in which a patient has an attractor of a healthy torus after a trauma, which is a bifurcation point. The body now chooses to return to the previous torus or to develop an adaptation torus. An adaptation torus is a new attractor developed in response to a trauma case, in which a patient would reject the natural strange attractor. After a trauma the body might choose this adaptation attractor, rather than returning to the original healthy attractor. The adaptation torus is a compensation type of attractor, in which the body, rather than returning to its original phase space torus, might choose another torus, an adaptation torus, as Selye discussed.

As Hopf bifurcations occur, the torus of the biology of the organism can choose different responses, and thus biofeedback loops. The sum total history is the response of society changing toruses in response to bifurcations. As various challenges occur; wars, natural disasters, or just ideas, these act as bifurcations, where society now must choose a response. Possibly the response of the old strange attractor might be reacted to. A society in response to a natural disaster might choose to return to its old sense of balances, and continue as if the natural disaster hadn't happened; or, as a result of the bifurcation of that disaster, a society might choose to find another set of morays, some way to help prevent the natural disaster, or perhaps a way to prepare for it. Or it might not have anything to do with a natural disaster at all; it might just be a result of a bifurcation producing the intent or the probability of change, or if nothing else, the chance for it.

So a society that witnesses a volcano erupting might have noticed that the first person it took was a young virgin, and then the volcano calmed down.

So the society might adapt a process of sacrificing such a virgin. This might become the moray of the society, and once every year or so, the young virgin will be sacrificed. This would have drastic effects on the rest of the society.

In response to different bifurcation points in society, social changes can be marked. We often also find that certain accidental cases can be sparked, such as the malaria epidemic that sparked the doctor to develop air conditioning. It was his theory that by cooling the patient he could cure malaria. His medical theory was untrue; however, his craftiness in supplying the world with air conditioning greatly changed society and the places where man could live and operate productively.

So our responses to bifurcations are often accidental, and sometimes intentional.

In 1975 Feigenbaum made a very significant discovery. Working on chaos theory, using a hand calculator, he tested equations and found universal types of period doubling similarities and their transformations. He explored equations in learning, population, solid state devices, optical systems, electrical circuitry, sound feedback, and so on. He supposed that the fine details did not really matter in these systems, and that the period doubling was the common factor that predicted the chaos entering into the system. He presented universal numbers, which he calculated with his hand calculator. These numbers correspond to the ways that a system goes into chaos, and then finds itself in order.

When a system works on itself through feedback, it will change in precisely the same way according to universal dynamics. The ratios that Mitchell Feigenbaum discovered will be known throughout the rest of time as the Feigenbaum numbers. These Feigenbaum numbers fall out of the hermitian matrices of Dr. Isaacs, showing how this system reverts chaos back onto itself, back to order. (See PROMORPHEUS) Our biology was able to do that through the determinate values of feedback started from the beginning process of the galaxy.

Regularity of the heartbeat was a key as to when there was going to be certain spasmodic or arrhythmic behavior. By changing the refractory time on different heart muscles, he could discover when to produce out-of-sync rhythms by period doubling. This produces the arrhythmia of tachycardia, often bradycardia, and definitely many other cardiac dysfunctions. These can often be the result of inappropriate negative feedback or positive feedback in the circuits, as well as external or internal limiting cycles. Many of these can cause problems in the cardiac rhythms. McGill University, Leon Gloss and their group found that by giving regular periodical stimulations to chicken heart cells, they could cause period doubling, and eventually chaos.

Walter Franceschini confirmed Feigenbaum's numbers. He analyzed various equations' modeling fluids in turbulence; thus the link between chaos/order and order/chaos was found to enter through the Feigenbaum numbers, which were predicted in the Isaacsonian hermitian matrix. Thus all of life is an iteration feedback through absorption, unfolding, processing toward chaos, approximating torus and new needs for DNA, and approaching new needs for order as we fight our battle against entropy. Iteration defines that normalcy and alteration are not opposites; neither are change and stability. The body remains stable; yet it is in a constant state of flux. This constant state of flux stays the same. This



HISTORY OF THE SCIO AND BIOFEEDBACK



THE SCIO
FINEST ENERGETIC MEDICINE



IN 1982 DR. NELSON WROTE THE FIRST EVER TREATISE ON QUANTUM BIOLOGY AND HE LAID THE GROUND WORK FOR THE SCIENCE OF THE QUANTUM XRROID INTERFACE SYSTEM.

FIRST DEVELOPED IN 1985 AND REGISTERED WITH THE FDA IN 1989 THE ELECTRO-PHYSIOLOGICAL FEEDBACK XRROID ENTERED THE MARKET PLACE. DAY TO DAY IMPROVEMENTS HAVE SHARPEN ITS OPERATION. THERE HAVE BEEN OVER A HUNDRED MEDICAL ARTICLES AND STUDIES PUBLISHED IN PEER REVIEWED MEDICAL JOURNALS ON THE TECHNOLOGY.

NOW REGISTERED IN MOST OF THE COUNTRIES OF THE WORLD THE EPFX TECHNOLOGY IS ADVANCING FAST. OVER 31,000 DEVICES HAVE BEEN SOLD WITH TREMENDOUS RESULTS WORLDWIDE. THE TESTIMONIALS FILE IS ASTOUNDING.

NOW THE SCIO AS IT IS CALLED TODAY OFFERS YOU THE FINEST ENERGETIC MEDICINE HAS TO OFFER WITH THE LARGEST MEDICAL SOFTWARE IN THE WORLD AVAILABLE FOR YOU.



advert/reklam
on the Collective Unconscious of the Universe
Subspace Treatise

is a flip-flop on the Janusian concept of psychology.

Dr 'Desire' Says that true Genius is just setting the Mind free to see both sides or poles of an Issue

This Is Called the janusian or Gemini effect

Janus, the great god of Rome whose face looked through the door both ways, in and out, shows us the power of Janusian psychology; the genius. The genius is able to see that something can be in a state of flux, and yet in a state of stability. Einstein saw that an object that is falling is actually at rest at the same time.

In O'Neil's play, "The Iceman Cometh", the Iceman represents both life and death. The truest pattern of genius in our science is the pattern of realizing that something can be both in yin and yang at the same time, and that opposites sometimes can be truly equal. This is the idea of iteration in fractal geometry, or chaos theory.

In 1960 an MIT weatherman, Edward Lorenz, was using computerized simulations to solve nonlinear equations of the Earth's atmosphere for weather conditions. As he ran one value, rounding off his figures to six places, he came up with a pattern of weather. Then, rounding off the figures to three decimal places, he set the computer into motion, went out to lunch, and when he returned, he had a tremendous

If you need more information on the SCIO and purchase details please get in touch with us

Maitreya Kft.

tel: +3613036043 | web: www.qxsubspace.com | e-mail: info@qxsubspace.com

realization; not only was his second forecast different, it was radically different. The small three-decimal place discrepancy of the two solutions grossly magnified the chaotic process. As Poincare would have pointed out, the small indeed can affect the large.

What would it take to really round off a computer for better results? Perhaps our pocket calculators are not enough; perhaps we need computers that can work at 1023, such as the triphasic computer system in the Eclosion system. Perhaps by working at 1023 we can establish how even the smallest intervention can have effects on the large. Joseph Ford called this the "roundoff error", the missing information, and we need to exceed seventeen, twenty-three, thirty-first iterations, to drastically improve our predictive capabilities. Through iterations alone, even the smallest type of fluctuation can have large-scale effects.

As indicated in Bio-Quantum Matrix, synchronicity in the generation of random number series can be affected by the indeterminacy principle of the human mind. Thus the development of a synchronicity random number generator that could match the amount of synaptic clefts in the human brain could perhaps be accessible to the vibrations and the morphic resonance, and bring meaningful data to bear.

As we have pointed out in this book several times, indeterminacy is the key to our quantum biology. This indeterminacy, as it plays in large number series, takes on fractal dimensions, where large-scale chaos and entropy become a predictability and a factor in biology.



The Butterfly Effect tells us
the Power of the Small
in a Fractal Chaos System

For hundreds of years scientists have sought to reduce the many mathematical variables to their meaningful components. This has been done through a quantifying mathematics. This type of quantifying mathematics reduces the complex imposing network of small forces and tries to calculate the large forces. So a bridge engineer would be concerned about force and structure, and would calculate toward one variable of force and resistance, letting the subtle iterations go as indeterminacy or experimental error.

Quantification in mathematics has been very powerful in the development of engineering, which has put a man on the moon and built large aircraft, automobiles and bridges. But our reductionistic quantification in mathematics has failed miserably to explain the phenomenon of biology, and especially the phenomenon of life itself, at the cellular level.

To this end, scientists recently have turned toward qualitative mathematics. In qualitative mathematics we don't look at the parts or reduce to simplistic forces; we look at the whole of the system, the Gestalt of the dynamic. We discover how the whole changes in response to even the smallest stimuli. Scientists are seeking to develop nonlinear, qualitative modes of analysis. Thus, in the Isaacsonian matrix, when metabolism moves from left to right, reproduction moves from top to bottom. The cross of the vector, showing the diagonal from upper left to lower right, shows the epigenetic phenomenon, which is where the hormones lie across that diagonal. Mass, momentum, energy, charge, information, storage retrieval, all happening through a ten-dimensional system in a trinary logic system present a rather strange and much more highly-evolved system of biology vs. what has gone before.

Biology is much more complicated than we ever imagined; in fact, biology might be more complicated than we ever can imagine.

Work	Intensity Factor	Capacity Factor
Gravitation Mass	Height Distance	Mass
Electricity Charge	Voltage Amperage	Charge
Momentum Expansion Momentum	Pressure	Viscosity
Heat Photon	Temperature	Q/T
Subspace Polymorphic Influence over subtle	morphic resonance	influence

These life energies will need to watch for separate types of entities that must be transferred and handled for life to ensue. These four transferrable processes are mass, momentum, energy and charge.

Mass is the convection of matter. Molecules, cell parts, membranes and golgi bodies have to be managed in a ten-dimensional space. Four of these are real, active, and reactive; whereas the other six are virtual, shadow-like, and passive/reactive.

Momentum has to do with the viscosity of liquid flow. A very viscus fluid in motion will have a momentum transfer; a light viscus fluid will have less momentum. Momentum has to do with velocity times mass. Thus we can see that the speed of interaction of oxygen, blood, hormones, ions, or other serum factors will be important in our transfer process.

Energy has its form in electromagnetic radiation, which is photon transfer. Here, the primary factor in biology is that of the photon of heat, which can be passed through conduction, convection or radiation. Other forms of electromagnetic radiation are also important in information control within our matrices.

Charge transfer deals with the electrical entities of electron, proton, ion, and electrostatic forces. These also must in biology for the factors of life to exist.

These units of mass, momentum, energy and charge, being four in number, can have twelve possible interactions, as one can interact and induce another. These are the basic transforms of energy that are accomplished and monitored by the cell. Activation energy, as we have discussed, might come from any

one of the four, or from any possible combination. This might serve as activation energy for enzymatic action, for neural transmission, or other cell metabolic events.

METABOLISM				
	MASS	MOMENTUM	ENERGY	CHARGE
R				
E				
P				
R	M	V	P	I
O	A	I	H	O
D	T	S	O	N
U	T	C	T	I
C	E	O	O	C
T	R	S	N	
I		I		
N		T		
		Y		

Thus the momentum and energies must be controlled through certain time and space dimensions. Each transfer acts as a transducer or converter of energy. Also each transfer is a potential information communicate. Nature tends to be economical. When energy needs to be transferred for metabolism or power, why not transfer information along with it?

Information	DNA	HORMONAL	PHOTON
Mass	Momentum	Energy	Charge
MITOGENIC CODING	TRIPLET	IONIC	Transfer
BLOOD AND LYMPHATIC		RADIATION	
	NEUROLOGICAL		

This will allow for reproduction and metabolism to occur through a controlled quantic organization of the flow of these energies and momentums through time and space.

As we have pointed out, these events are happening intracellularly, and since they are within the cell, they fall under the dimensions of quantum dynamics. Since they are quantic, they will not make distinct steps; they will move in quanta, and they will also follow the uncertainty principle. Thus any type of graph that would be of a continuous flow nature would be an inappropriate way to classify these. To classify these changes we will need to develop a hermitian matrix, which will show the dynamic jumps and allow for an uncertainty of those jumps from one level to the other. This uncertainty matrix has been given by Dr. Isaacs, and we will give an account of it later in this chapter.

TYPES OF SUBCELLULAR VIONS: NUCLEI -REPRODUCTION CENTRIQLES -TRANSPORT KINETOSOMES -MOVEMENT PLASTIDS -LIGHT REGULATION MITOCHONDRIA -ENERGY MICROTUBULES -TRANSPORT

Metabolism and reproduction lie on the dimensions of this graph, as we handle mass, momentum, energy and charge through factors of time and space.

Thus a cell can intake any one of these various energies and momentums and convert them into a living process via the transforms of life.

Summary

1. *The complementarity principle states that biological living functions fall under quantum rule.*
2. *Mass, momentum, photons, viscosity, subspace morphic transfer, and charge are the basic transfer media of forces that need to be accounted for.*
3. *These forces are additive.*
4. *These forces can transfer information, physical or otherwise.*
5. *The synaptic cleft is an indeterminate photon process, not merely a chemical one and as such is effected by subspace morphic transfer.*
6. *Thus all of synthetic pharmacology is an unnatural demand of action by overloading the synaptic cleft.*
7. *Indeterminacy is affected by some other unexplained power. This power seems to be correlated with psi, and explains psychic phenomena. (Nelson effect, as subspace transfer of consciousness)*
8. *Human beings might have power beyond time and space by developing wormhole in the endorphin area of the brain. This occurs through a subspace connectivity over the subtle quantic nature of all things. There is a shape constriction over the degrees of freedom of systems, producing a pattern or shape enhancing effect. We refer to this as the Nelson effect.*
9. *Indeterminacy methods of medicine have some degree of efficacy above chance.*

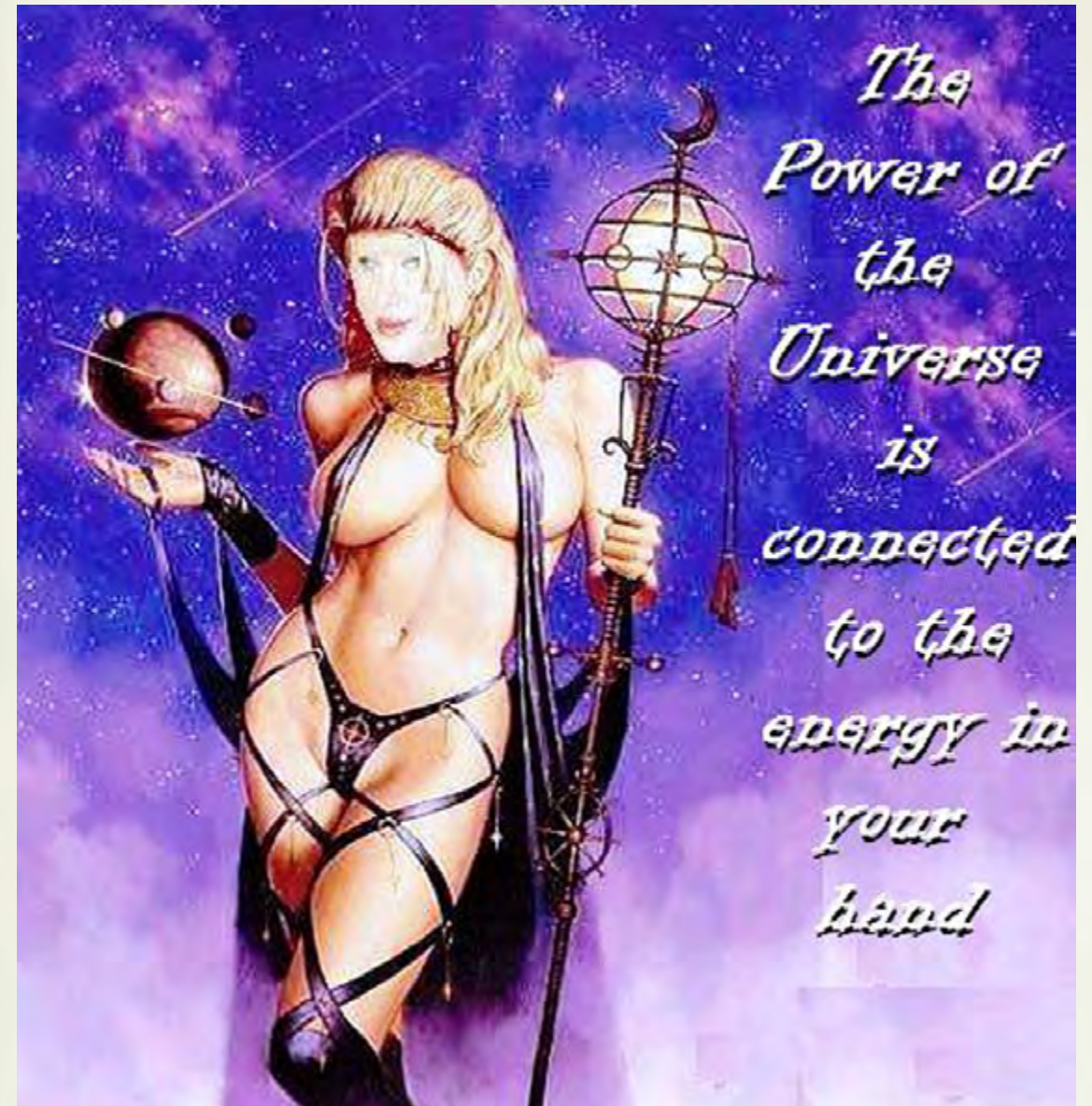

*Matter is Energy,
Our Bodies are made
of Energy Fields That
We can not Percieve
Some of these fields
have a spiritual
source that act
upon a person's
Soul. This Soul is
developed thru a
Process of Guided
Self Observations*



*However this is
rarely Achieved
due to man's
unique ability to
be Distracted
from Spirit
and Spiritual
Matters by
EveryDay
Trivia and
emotional
desires of*

*Greed, Anger,
Arrogance,
Delusion and
Conformity
Distract us
from Spirit
and Spiritual
Development*

*Desire '
Delicious
Dubounet*

Dimensional Travel+ Egyptian Wheels



In order to understand where the wheels are in the power wheel, you have to study the tremendous levels of knowledge contained within it. You would never get there by just looking at designs. It's nothing that you could just happen on-you'd have to know the ancient secret of the power wheel. That's called the power wheel the egg of metamorphosis. The neters are concentrated on the time when we go through a certain stage of resurrection, which is a rapid biological change into a different life form. They're holding an image of that transition as they're walking along the line, then suddenly the line comes to an end and there's a 90-degree shift upward, and they're walking perpendicular to their first direction. This 90 degrees is a very important part of this work. The 90-degree turn is crucial to understanding how to make resurrection or ascension real. The dimensional levels are separated by 90 degrees; musical notes are separated by 90 degrees; the chakras are separated by 90 degrees-90 degrees keeps coming up over and over again. In fact, in order for us to enter into the fourth dimension (or any dimension, for that matter), we must make a 90-degree turn. The wheel with spokes is needed for it shows us that our lives need to have many support areas. If one area is too big then the wheel is unbalanced. The humans must balance the life areas. Also the center must have a void just as in the Buddhist tradition the core should be the emptiness. This will allow for the transcendence of relocation. Probably at this point we need to make sure we have a common understanding about what dimensions are-like third dimension, fourth dimension, fifth dimension and so forth. What are we talking about? I'm not talking about dimensions in a normal mathematical sense, as in the three axes or so-called dimensions of space: the x, y and z axes-front to back, left to right and up and down. Some people call these three axes the third dimension and say that time becomes the fourth dimension. This is not what I'm talking about.

Dimensions, Harmonics and the Waveform Universe

What I'm seeing as the various dimensional levels has to do more with music and harmonics than anything else. There are probably different connotations of what I'm talking about too, though most people who study this agree. A piano has eight white keys from C to C, which is the familiar octave, and in between those are the five black keys. The eight white keys and the five black keys produce all the sharps and flats in what's called the chromatic scale, which is thirteen notes (actually twelve notes, with the thirteenth beginning the next octave). So from one C to the next is really thirteen steps, not just eight. Keeping that in mind, look at the concept of a sine wave. Sine waves correspond to light (and the electromagnetic spectrum) and the vibration of sound. In the entire Reality we're in, every single thing is based on 3 dimensional sine waves. There are no exceptions. Everything in this Reality is 3d sine wave, or cosine, if you want to look at it like that. What makes one thing different from another is wavelength and pattern. A wavelength extends from any point on the curve to the point where the entire curve starts over, as from A to B on the longer wavelength, or from C to D on the shorter wavelengths. If you get into a really long wavelength, they look almost like straight lines. For example, your brain waves are about ten to the tenth power centimeters, and they're almost like straight lines coming out of your head. Quantum physics or quantum mechanics looks at everything in the Reality in one of two ways. They don't know why they can't look at it in both ways at once, though the geometries tell why if you study them very carefully. You can consider any object, such as a book, as being made up of tiny particles like atoms; or you can forget that idea and just look at it as a vibration, a waveform, such as electromagnetic fields or even sound, if you like. If you look at it as atoms, the laws can be seen to fit that model; if you

look at it as waveforms, the laws can be seen to fit that model. Everything in our world is a waveform (sometimes called pattern, or sine-wave signature) or could even be seen as sound. All things-your bodies, planets, absolutely everything-are waveforms. If you choose this particular way of looking at Reality and superimpose that view over the reality of the harmonics of music (an aspect of sound), we can begin to talk about different dimensions.

Wavelength Determines Dimension

The dimensional levels are nothing but differing base-rate wavelengths. The only difference between this dimension and any other is the length of its Basic waveform. It's just like a television or radio set. When you turn the dial, you pick up a different wavelength. Then you get a different image on your TV screen or a different station on your radio. It's exactly the same for dimensional levels. If you were to change the wavelength of your consciousness, and in so doing change all your body patterns to a wavelength different from this universe, you would literally disappear out of this world and reappear in the one to which you were tuned. This is exactly what the UFOs do when you see them shooting across the sky, if you've ever seen one. They shoot across at unbelievable speeds, then make a 90-degree turn and disappear. The people onboard those ships are not being carried through space like we are on airplanes. Spaceship passengers are consciously connected psychically to the vehicle itself, and when they get ready to go into another world, they go into meditation and link all aspects of themselves into oneness. Then they make either a 90-degree shift or two 45-degree shifts all at once in their minds, actually taking the whole ship, along with its passengers, into another dimension. This universe-and by that I mean all the stars and atoms going infinitely out and infinitely in forever-has a base wavelength of about 7.23 centimeters. You can pick any spot in this room and go infinitely in or infinitely out forever within this particular universe. In a spiritual sense this 7.23-cm wavelength is Om, the Hindu sound of the universe. Every object in this universe produces a sound according to its construction. Each object makes a unique sound. If you average the sounds of all the objects in this universe, this third dimension, you would get this 7.23-cm wavelength, and it would be the true sound of Om for this dimension. This wavelength is also the exact average distance between our eyes, from the center of one pupil to the other-that is, if you take a hundred people and average them. It's also the exact average distance from the tip of our chins to the tip of our noses, the distance across our palms and the distance between our chakras, to give a few more examples. This 7.23-cm length is located throughout our bodies in various ways because we are emerged within this particular universe, and it is embedded within us. It was Bell Laboratories that discovered this wavelength, not some spiritual person sitting in a cave somewhere. When they first put up the microwave system that went around the United States and pulled the on switch, they found static in their system. You see, Bell Labs just happened to pick for the system's sending frequency one slightly longer than seven centimeters. Why they chose that wavelength, I don't know. They tried to find the static, looked through their equipment, tried everything they could. First they thought it was coming from inside the Earth. Eventually they looked into the heavens and found it, and said, "Oh, no, it's coming from everywhere!" In order to get rid of the static, they did something that we as a nation and a planet are still suffering from: They upped the power 50,000 times over what they would normally need, which created a very powerful field, so that the 7.23-cm wavelength coming from everywhere would not interfere.

Dimensions and the Musical Scale

Some believe that 7.23 centimeters is the wavelength of our universe, this third dimension. As you go up into dimensional levels, the wavelength gets shorter and shorter, with higher and higher energy.

As you go down in dimensional levels, the wavelength gets longer and longer, with lower and lower energy, more and more dense. Just as with a piano, there's a space between the notes, so that when you hit one note, there's a very definite place where the next note is. In this waveform universe we exist in, there is a very definite place where the next dimensional level exists. It's a specific wavelength relative to this one. Most cultures in the cosmos have this Basic understanding of the universe, and they know how to move between dimensions. Our Society has forgotten it all. But our initial experiments have allowed us to recover this learning.(see QXCI).

Musicians, music theorists and physicists discovered long ago that there are places between the notes called overtones. Between each step of the chromatic scale there are twelve major overtones. (A group in California has discovered over 200 minor mathematical overtones between each note.) If we show each note in the chromatic scale as a circle, we have thirteen circles. Each circle represents a white or black key and the shaded circle at the end would be the thirteenth note that begins the next octave. The black circle on this illustration represents the third dimension, our known universe, and the fourth circle, the fourth dimension.

The twelve major overtones between any two notes, or dimensions, are a replica of the larger pattern. It's holographic. If you carry it further, between each overtone you'll find another twelve overtones that replicate the whole pattern. It goes down and up literally forever. This is called a geometrical progression, only in harmonics. If you continue to study it, you'll find that each of the unique musical scales that have been discovered produces a different octave of experience-more universes to explore! (This is another subject we will come back to.)

You've probably heard people talk about the 144 dimensions and how the number 144 relates to other spiritual subjects. This is because there are twelve notes in an octave and twelve overtones between each note; and $12 \times 12 = 144$ dimensional levels between each octave. To be specific, there are 12 major dimensions and 132 minor dimensions within each octave (though in truth the progression goes on forever) . This diagram represents one octave.

The thirteenth note repeats, then there's another octave above that one. There's an octave of universes below this and an octave above, and it stretches on theoretically forever. So as big and as infinite as this universe seems (which is just an illusion anyway), there are still an infinite number of other ways to express the one Reality, and each dimension is experientially completely different from any other.

That's what much of this teaching is about-reminding us that we here on Earth are sitting in the third dimension on a planet that is in the process right now of becoming fourth-dimensional and beyond. The third-dimensional component of this planet is about to be nonexistent for us after a

while-we're going to be aware of this dimension for only a short time longer. First we'll go into certain overtones of the fourth dimension. Most people in the higher dimensions who are watching and helping with this process now believe that we're going to keep moving on up through higher dimensions quite

rapidly.

The Wall between Octaves

Between each whole-note universe and between each subspace or overtone universe, there is nothing-no thing, absolutely zip. Each of these spaces is called a void. The void between each dimension is called the duat by Egyptians or the bardo by Tibetans. Each time you pass from one dimension or overtone into the next, you pass through a void or blackness that's in between. But certain voids are "blacker" than others, and the blackest of these exist between the octaves. They're more powerful than the voids that exist within an octave.

Please understand that we are using words that cannot fully explain this concept. This void that exists between octaves can be called the Great Void or the Wall. It's like a wall you have to pass through to get to a higher octave. God put these voids there in a particular way for certain reasons that will soon become apparent.

All of these dimensions are superimposed over each other, and every point in space/time contains them all. The doorway to any of them is anywhere. That makes it convenient-you don't have to go looking for it, you just have to know how to access it. Although there are certain sacred places in the geometries of our reality here on Earth where it's easier to become aware of the various dimensions and overtones-sacred sites, which are nodal points connected to the Earth and the heavens (we'll also talk about them later)-there are also specific places in space that are tied to the geometries of space.

These places are sometimes referred to by explorers as star gates, openings to other dimensional levels where it's easier to get through. But in truth, you can be anywhere to go anywhere. It really doesn't matter where you are if you truly understand the dimensions and, of course, are capable of divine love.

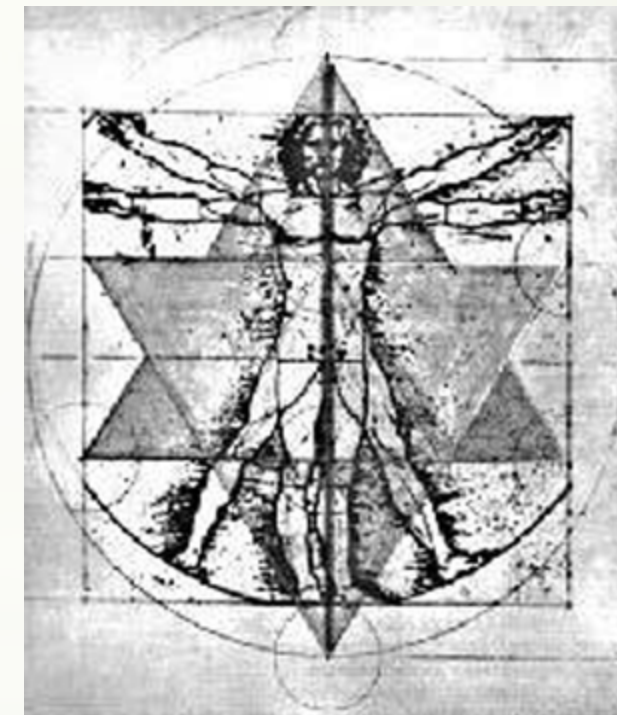

Changing Dimensions

In the past our ancient ancestors could change dimensions. And those power wheels are connected to the harmonics of music-and you now know that the harmonics of music are connected to the dimensional levels. These wheels are actually telling us exactly where they went, into which dimension.

The Star Tetrahedron

This star tetrahedron with Leonardo's image behind it is going to become one of the most important drawings for this work. What you're looking at is two-dimensional, but think of it in three dimensions. A star tetrahedron, just as shown here, happens to exist around each human body. We're going to spend a great deal of time to get you to the point where you can see that you do have this image around your body. Notice especially that there's a tube running down the center of the body through which we can breathe life-force energy, and the two apexes at the top and bottom of this tube connect the third dimension to the fourth dimension.

You can inhale fourth-dimensional prana directly through the tube. As Richard Hoagland has shown the United Nation and NASA, we are now beginning to scientifically rediscover this field. Just as it is shown around Leonardo, it is also around planets, suns and even larger bodies. This could become the standard explanation of how some of these outer planets survive.

Why? The planets are radiating off the surface far more energy than they're receiving from the Sun, a lot more. Where is it coming from. With this new understanding, if Leonardo were a planet instead of a person, the points at the north and south poles would be bringing in huge amounts of energy from another dimension (or dimensions). Planets literally exist in more than one dimension, and if you could see the whole Earth in all its glory-the various fields and energies around a planet-you'd be astounded. Mother Earth is far more intricate and complex than we at this dense level can perceive. This channeling of energy is actually how it works for people, too. And the particular dimension (or dimensions) that this energy comes from depends on how we breathe.

On Leonardo's drawing, the tetrahedron pointing up to the Sun is male. The one pointing down toward the Earth is female. We're going to call the male one a Sun tetrahedron and the female one an Earth tetrahedron. There are only two symmetrical ways that a human being can look out of this star-tetrahedral form with one point of the star above the head and one point below the feet and with the alignment of the human body looking toward the horizon: For a male body looking out of his form, his Sun tetrahedron has a point facing forward, and the opposite fiat face is behind him; his Earth tetrahedron has a point facing out the back, and the opposite fiat face is in front.

For a female body looking out of her form, her Sun tetrahedron has a fiat face forward, and a point facing out the back; and her Earth tetrahedron has a point facing forward, and the opposite fiat face is behind her. We would like to introduce other aspects so that you can begin to remember and prepare yourself for the eventual reactivation of your light body, the Mer-Ka-Ba. Beginning soon, we'll start talking about yogic breathing, which probably many of you are already familiar with. Then we'll learn about mudras after that. We're going to keep going step by step until we are ready to experience spherical breathing, the state of being from which your Mer-Ka-Ba can come to life.

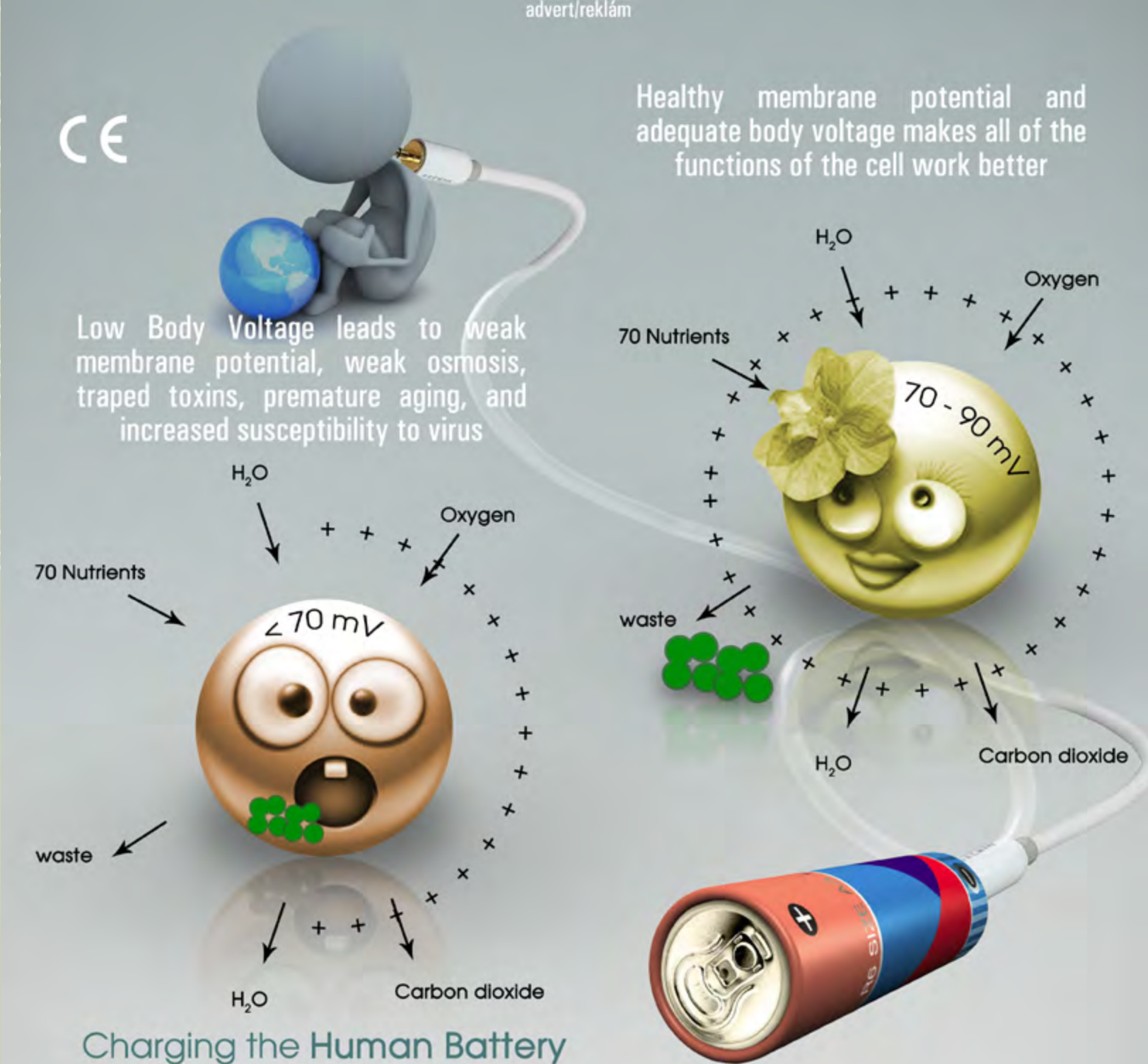

Factors that influence the body voltage and membrane potential are fatty acids in the cell membrane, minerals, especially salts, hydration water, oxygenation, stress, toxins and life style.

The SCIO has been proven in tests to increase the electrical potential of the body. Increased cellular membrane potential makes osmosis increase, which increases detoxification, nutrient transfer and absorption, hydration, oxidation, and all cellular functions in general.

If you need more information on the SCIO and purchase details please get in touch with us

Maitreya Kft.

tel: +3613036043 | web: www.qxsubspace.com | e-mail: info@qxsubspace.com

Three make two: The Holy Trinity

To understand the situation here on Earth, we will offer another piece of information to refer to as we proceed. In nature, the law of opposites appears to be manifesting throughout our reality, such as male and female or hot and cold. In truth, this is incomplete. Actually, every manifestation in our reality has three components. You hear people talk about male and female polarity and about polarity consciousness; that isn't the full truth. There has never been a polarity in this reality without a third component, with one rare exception we will talk about in a moment. There is a trinity in almost every situation. Let's think of some examples of what we usually call polarity. How about black and white, hot and cold, up and down, male and female and Sun and Earth? For black and white, there's gray; for hot and cold, there's warm; for up and down, there's the middle; for male and female, there's a child, for the Sun and the Earth (male and female), there's the Moon (child). Time is also in three components: past, present and future. The mental relationship of how we see space is with the x, y, z axes-front and back, left and right, up and down. Even in each of these three directions there's a middle or neutral point, creating three parts. Probably the best example is the fabric of matter itself in this third dimension.

Matter is made of three Basic particles: protons, electrons and neutrons. On the next higher level of organization from the three Basic particles you will find atoms, and on the next lower level, finer particle divisions. In a similar manner, consciousness perceives itself in the middle between the macrocosm and the microcosm. If you look closely into either level, you will always find threeness.

There is a special exception, as there almost always is. It relates to the beginning of things. Primal aspects usually do have twoness, but they are extremely rare. An example is found in number sequences. Sequences such as 123456789 . . . , or 2-4-8-16-32 . . . , or 1-1-2-3-5-8-13-21 . . . —and in fact all sequences known—strangely enough need a minimum of three successive numbers of the sequence in order to calculate the entire sequence, with one exception: the Golden Mean logarithmic spiral, which needs only two. This is because that spiral is the source of all other sequences. In the same manner, atoms all have three parts, as mentioned before,

with the single exception of the first atom: hydrogen. Hydrogen has only one proton and one electron; it has no neutron. If it has a neutron, which is the next step up, it is called heavy hydrogen, but the very beginning of matter has only two components.

Since we mentioned numbers exhibiting threeness, we might as well bring up color. There are three primary colors from which the three secondary colors are created. This means that the universe as we now know it—all created things—is composed of three primary parts except in its rare primal areas. In addition, the very nature of how the universe is perceived by human consciousness is through the three major ways we just spoke of: time, space and matter, all of which are reflections of the sacred holy trinity.

I PRAYED TO *God*

*I prayed to God to give me the Wisdom of Solomon, he gave me major Problems to solve
I asked God for Strength, he gave me Resistance to make me Strong*

I asked God for Intellect, he gave me the Light of Enthusiasm and the Breath of Inspiration

I asked God for Courage, he gave me Obstacles to overcome and Hatred and Anger to defeat

I asked God for Love, and he gave me Suffering People to help, he gave me Opportunity to grow and Opportunities to help other

I did not get what I wanted... but God gave me what I needed day by day



Knowledge is Ever Expanding + Infinite in every Direction

Most people by now are aware that something unusual is going on here on Earth. We are in extremely accelerated time, and many events are happening that have never been seen before. There are more people on the planet than have ever been known before, and if we continue at the same rate, in a few more years we will double our population to about eleven or twelve billion people.

Regarding our human evolutionary learning curve, the supply of information on the planet is growing far faster than the population. Here's a fact according to the Encyclopedia Britannica. From the time of our oldest known human civilization, the ancient Sumerians (circa 3800 B.C.), continuing for almost 5800 years until about A.D. 1900, a certain number of bits of information had been collected, a certain number of so-called facts that were added up to determine precisely how many things we knew. Fifty years later, from 1900 to 1950, our knowledge had doubled. That means it took 5800 years to learn a certain amount, then it took fifty years to double it-amazing! But then in the next twenty years, by about 1970, we doubled it again. It took only ten more years, to about 1980, to double that! Now it's doubling every few years.

Knowledge is coming in like an avalanche. The information was coming so fast in the mid-eighties that NASA couldn't put it into their computers fast enough. I heard that in approximately 1988 they were eight or nine years behind in simply entering the incoming data. At the same time this avalanche of knowledge is building up, the computers themselves, which are boosting the acceleration, are about to make a huge change. Approximately every eighteen months computers are doubling both speed and memory. First we came out with the 286, then the 386; then we had the 486, and now the 586 is out [this was 1993], which makes the 486 obsolete. We didn't even know how to use the 486 yet, and here's the 586. Pentium 1,2,3,4,5, Now the home computer is so powerful and fast that it has surpassed all of (1990) computers of NASA and the Pentagon combined.

Soon the home single computer will be so fast and powerful that it can actually watch the whole Earth and give constant weather data for every square inch of the planet. It will do things that now seem absolutely impossible. And we're beginning to speed up our ability to enter the data: Now huge amounts of information are entered directly from other computers and scanners and direct voice. So with this incredible amount of knowledge entering into human consciousness, it becomes obvious that a major change for humankind is being birthed.

For thousands of years spiritual information was kept secret. Priests and priestesses of various religions or cults would give their lives to keep the rest of the world from knowing about one of their secret documents or piece of spiritual knowledge, making sure it remained secret. All the various spiritual groups and religions around the world had their secret information. Then suddenly, in the mid-sixties, the veil of secrecy was lifted. In unison, almost all the spiritual groups of the world opened their archives at the same moment in history. You can browse through books in your neighborhood bookstore and see information that has been sealed and guarded for thousands of years.

Life on this planet is accelerating faster and faster and faster, obviously culminating in something new and different, perhaps just out of the reach of our normal imagination. We are always changing. What

does this mean for the world? Why is it happening? Better yet, why is it happening now? Why didn't it happen a thousand years ago? Or why didn't it wait to happen 100, 1000 or 10,000 years from now? It's really important to understand the answer to this question, because if you don't know why this is happening now, then you probably will not understand what's happening to you in your life or be prepared for the coming changes.

Though I don't want to get into the real meaning of what this is about right now, one of the answers lies in the fact that the computer is made out of silicon and we're made out of carbon. It's tied into the relationship of silicon and carbon, but I'll leave that for a while and continue with the unusual nature of what's happening here on Earth.

For a long time astronomers pretty much thought that what you saw out there was it; if you could see it, it was there. They were either totally oblivious to the invisible side of Reality, or they didn't feel it was that important. But the invisible side of our Reality is actually much greater than the visible side, and probably more important. In fact, if the full electromagnetic spectrum were a line about two yards long, then visible light, with which we see objects, would be a band about 1/32 of an inch wide. In other words, the visible part of the Reality is far less than one percent of the total-almost nothing. The invisible universe is really our true home. There's much more. There are things even beyond the electromagnetic spectrum that we're just beginning to understand. For example, they've discovered that when an old sun explodes and dies, it seems to occur only in the dark area of the spiral

This indicates that there is a difference between deep space and the inner space between the light spirals. So they're beginning to realize there's a distinct difference between the two areas of space as well as between the dark and the light areas of the galaxy. There's something different about the dark areas of the spiral that seems to be related to the light areas.

Our Sirius Connection

Observing these characteristics of a galactic spiral led to another discovery. Other scientists noticed that as our solar system moves through space, it's not moving in a straight line, but in a helical pattern, a spiral. Well, such a spiral is not possible unless we are gravitationally connected to another large body, such as another solar system or something larger. For example, many people think the Moon rotates around the Earth, right? It does not. It never has. The Earth and the Moon rotate around each other, and there's a third component between them approximately one-third of Update: This update will not make complete sense until you fully understand the Mer-Ka-Ba, but this is the most appropriate place to put it. Astrophysicist William Purcell has just discovered (reported May 12, 1997, in Time magazine) that "a colossus of antimatter,"

a tube at 90 degrees to the plane of the galaxy, "is spewing out from the center of our galaxy and reaching trillions of kilometers into space." This resembles the same geometries of the Mer-Ka-Ba on a galactic level. At the same time, Cornell astronomers have discovered that about 80 percent of the stars in the galaxy NGC 4138 (mostly older stars) are rotating in one direction, whereas about 20 percent of the stars (mostly younger stars) are rotating in the opposite direction along with a huge cloud of hydrogen gas.

Their findings were presented on January 18, 1997, at the American Astronomical Society. This is a

the distance from the Earth to the Moon, which is the pivotal point, and the Earth and Moon rotate around this point in a helical pattern as they also move around the Sun. This happens because the Earth is connected with a very large body, which is the Moon. Our moon is huge, and it's causing the Earth to move in a particular pattern. And since the entire solar system is spiraling in the same manner through space, then the whole solar system must be gravitationally connected with some other very large body.

So astronomers started searching for this body that was pulling on our solar system. They first narrowed it down to a certain area of the sky that we were linked with, then they narrowed it down further and further, until just a few years ago they finally pinned it down to a specific solar system.

We are linked with the star Sirius-with Sirius A and Sirius B. Our solar system and the Sirius system are intimately connected through gravitation.



We move through space together, spiraling around a common center. Our fate and the fate of Sirius are intimately connected. We are one system! Ever since scientists have known about the dark area inside a spiraling galaxy being different, they have discovered that stars don't just move out along the curved arm of a spiral. If someone spun a water hose over his head and you viewed the scene from above, you would see droplets that appeared to move in spirals. Can you envision that? Each individual drop, though, is not moving in a spiral, but is moving radially away in a straight line from the center; it only appears to be moving in spirals. It's the same way in a galaxy.

Each of these stars is actually moving radially away. At the same time the stars are moving radially away from the center, they are also moving, independent of the system as a whole, from one arm through the dark light into the white light, orbiting the whole galactic system. It probably takes billions of years-I don't know-for one cycle to complete itself.

Imagine a galaxy viewed from above and that the dark color represents the black-light spirals, and the light color represents the white-light spirals. From the edge it looks like a flying saucer. The orbit we make around the center of the galaxy has within it a spiral motion similar to a coiled spring. In addition to our solar system, the same spiral motion is seen between Sirius A and Sirius B. The spiral of the Earth and the Moon, I believe, is different. This spiraling motion of the two Sirian stars just happens to be identical to the geometries of the DNA molecule, according to an Australian scientist. This makes you suspect that perhaps there's a relationship in the unfoldment of things, that events happen according to some kind of larger plan, similar to the unfoldment of a human body guided by the information within the DNA.

Of course, it's only speculation, but because of the principle "as above, so below," this is highly probable. So we have two related questions to answer. One is why Sirius is so important, which has been explained by our gravitational connection to it. Another is, why is this extremely rapid pattern of evolution we are experiencing on Earth today taking place at this moment in history? Let's keep looking in the heavens. First, here are two incidental pieces of information to share.

A Galaxy's Spiral Arms, Surrounding Sphere and Heat Envelope

They've found that spheres of energy surround galaxies. Notice the tiny galaxy with its spiraling arms, along with a bunch of loose stars, all enveloped in the sphere of energy. Then outside that sphere is another enormous sphere of energy, shown here as a hexagonal grid. So there's a huge sphere inside a smaller sphere, with a tiny galaxy inside it. As we progress, you're going to see that you have exactly the same field around you. This heat envelope is in exactly the same proportions as the Mer-Ka-Ba around your body when it's activated through breathing and meditation.

When you follow a certain breathing procedure, you'll find that a field about 55 feet wide will form around your body that looks like this heat envelope. With the proper equipment, you could see it on a computer screen, since it does have an electromagnetic component in the microwave range. This is very real stuff. It is the same shape of the Mer-Ka-Ba that, if you so choose, you will activate around your body.

Precession of the Equinoxes and Other Wobbles

Going on to why this change is happening at this moment: Our Earth currently tilts approximately 23 degrees to the plane of its orbit around the counter rotating field. Not only do galaxies look like Mer-Ka-ba fields, but they appear to have the same internal dynamics! (Of course, I personally believe that galaxies are living beings, and that they are really nothing but a huge living Mer-Ka-Ba field.) In addition, physicists at the University of Rochester and the University of Kansas have found evidence that changes the long-held belief that space is the same in all directions. Researcher John Ralston reported that "there seems to be an absolute axis, a kind of cosmological North Star that orients the universe."

This work is published in the April 21, 1997, issue of Physical Review Letters. They have also discovered that light travels differently along this axis than anywhere else. There are now two known different speeds of light! The axis is the key to the living Mer-Ka-Ba field, and this finding may eventually prove that the entire universe is really just a giant living Mer-Ka-Ba field. After you are aware of your own Mer-Ka-Ba field, your mind will achieve peace. Sun, and as the Earth orbits the Sun, the angle that the light hits the surface of the Earth changes, depending on where it is in its orbit. This is why we have four seasons.

Within this yearly rotation there's another very slow wobble, which most people know as the precession of the equinoxes, which takes almost 26,000 years to complete. To be more accurate, it's about 25,920 years-it depends on who you read, because everybody comes up with a few years' difference. There are other wobbles, too. For example, that + 23-degree angle to the Sun is not fixed; there's a wobble of about 40,000 years where it changes about three degrees-from about 23 to about 26 degrees. Then there's another wobble inside the little three-degree wobble that completes a cycle about every fourteen months. And they've discovered another one

that completes about every fourteen years. Now they say they've discovered yet another one. If you read the ancient Sanskrit writings, all these wobbles are profoundly important for consciousness on the planet. They're tied directly to specific events and to the time these events happen on the planet-just as our DNA is tied to the various phases in the growth of the human body.

For now I just want to look at the main wobble, which is called the precession of the equinoxes. This wobble moves in an oval pattern, and the large oval in is the wobble itself. The right end, on the long axis of the oval, is called the apogee, which points toward the center of

the galaxy. The bottom half of the oval shows when the planet is heading toward the center of the galaxy, and the top half shows when the planet has come back around and is heading away from the center. This movement away from the center of the galaxy is also called going with the galactic wind. The Sanskrit writings say that the ancient beings-who somehow knew

about the precession-say that it's not at the far ends of this oval when great change takes place, but slightly after these extreme points are passed-at the points indicated by two small ovals. Great change takes place at those two points.

The Mayans write that near the end there will come the Hero Twins. Two in one and of both sexes. The Hero Twins are the children of KulKulcan. KulKulcan was the leader of the Mayans before the arrival of the Europeans. He was not a Mayan. He had white skin and long blonde hair as will his children.

Thus the two in one heroes with white skin and long blonde hair, will come just before the end of the calendar. They must defeat the evil, they must defeat arrogance, they must defeat Greed. If they can then the world will not end.

The Angel is not here to cause the upheaval.

The weatherman does not cause the weather just because he reports it.

But the Angel has come to say the message. If the human race can conquer Greed, Arrogance and Delusion, if the human race can defeat the Mastery of Big Money, the destruction of the human race and this cataclysm can be prevented.

This book is the basis of the Angel's message. To judge a messenger you must judge the message. To judge this Angel you must judge this book. Big Money wants to discredit the messenger.

But you must be able to see past the twist and distortion of Big Money and judge the message for yourself. Then you can judge the messenger after you judge the message.

The messages are simple and the solution to Earth's problems are in this book.

ANGEL & THE GLOBE



OPHIACUS

THE ANGEL THAT MUST DEFEAT THE LIZARD AND AVERT THE 2012 CRISIS

You see on the 20th day of the 12th month of the year 2012, there will be a massive force of gravity applied to the Earth. The surface of the outer crust of our planet will be pulled. The inner molten core which is revolving like a spinning top will resist the movement. This will torque the planet's crust, and possibly move the crust over the resisting inner core, like the outer skin on a tangerine. The force might take days, weeks, months or some years to manifest into a massive earthquake.

A force 16 on the Richter scale earthquake everywhere on the planet could result. This would destroy all structures, all infrastructure, all roads, all resources, and kill 95% of the people. Oceans will be displaced, rivers moved, mountains created, tremendous upheaval.

This would throw the human race back to the stone age. The few survivors will not even be able to bury the amount of dead people, disease and starvation will threaten any survivor. There is evidence of this having happened in the past, but 26,000 years ago there was no human society to observe it. But an angel has come not only with a message, but a way to prevent it. Contained in this book is the solution.

The threat of total destruction

The Mayan Indians had the most precise calendar ever and they had exemplary knowledge of Astronomy. They knew of the orbit of the sun around the Milky Way. An orbit that takes 26,000 years to complete. On a certain day of this orbit our solar system will be closest to the gravity black hole center of the Milky Way. We can see gravity everyday. We see how the gravity of the moon pulls at the oceans and make tides. The gravity of the sun holds us in a 365 day orbit of one year. The gravity of the black hole at the center of our galaxy holds our sun in orbit. One year every 26,000 years all of these will align and the pull on the Earth will be the greatest.

How could a man leave America to find freedom, and is no longer a man, but through the will of God, he/she becomes an Angel to save the planet.

The Angel makes over forty movies (Major Motion Pictures), over 80 books on the modern science, over 100 medical journals, over 250 articles, three 24-7 TV channels, 3 radio channels, record over 300 songs, over 60 original songs, multiple patents, copyrights, and science awards? And yet no one know of this angel.

The ultra rich do not want you to read this book for it will change you, it will change the world. This is a true story of an Angel sent by God to lead us to a thousand years of peace.

the HERO TWINS



The Mayas write that near the end there will come the Hero Twins. Two in one and of both sexes. The Hero Twins are the children of Kukulcan. Kukulcan was the leader of the Mayas before the arrival of the Europeans. He was not a Mayan. He had white skin and long blonde hair as will his children. Thus the two in one heroes with white skin and long blonde hair, will come just before the end of the calendar. They must defeat the evil, they must defeat arrogance, they must defeat Greed. If they can then the world will not end.

The Angel is not here to cause the upheaval. The weatherman does not cause the weather just because he reports it. But the Angel has come to say the message. If the human race can conquer Greed, Arrogance and Delusion, if the human race can defeat the Mastery of Big Money, the destruction of the human race and this cataclysm can be prevented.

This book is the basis of the Angel's message. To judge a messenger you must judge the message. To judge this Angel you must judge this book. Big Money wants to discredit the messenger. But you must be able to see past the twist and distortion of Big Money and judge the message for yourself. Then you can judge the messenger after you judge the message. The messages are simple and the solution to Earth's problems are in this book.

SUPER-POWERS OF THE *Angel*

1. Clarity of Mind: to be able to see through the delusions of false belief.

2. Grace: to have love respect and compassion for all to conquer the fear, hate and anger.

3. Courage: to confront the true problem in the world today, Rich Powerful Arrogant people who engage small petty minds to do their bidding.



4. Focused Gallant Bravery: to confront the small-minded picayune self righteous scientific community and the FDA.

5. Generosity: to help others and fight the forces of greed.

6. Humor: The ability to laugh at oneself, take one self lightly, and see the cosmic joke of the mystery, conundrum, enigma and never ending paradox of life, I hope you see the jest I present.

Yugas

The Tibetans and the Hindus called these particular time periods yugas, which are simply ages. Each yuga has both a descending and ascending phase, so if you use the Hindu system, the age around the top oval at C is called the descending satya yuga. Then comes the descending treta yuga, dwapara yuga, and kali yuga at the other end. In the kali yuga you have both descending and ascending. Then you enter the ascending dwapara and so on. We're now in the ascending dwapara yuga. We're out of the kali yuga by about 900 years, and right now is the time when amazing things are predicted to happen. The world is now rediscovering for itself that these are periods of enormous changes on Earth.

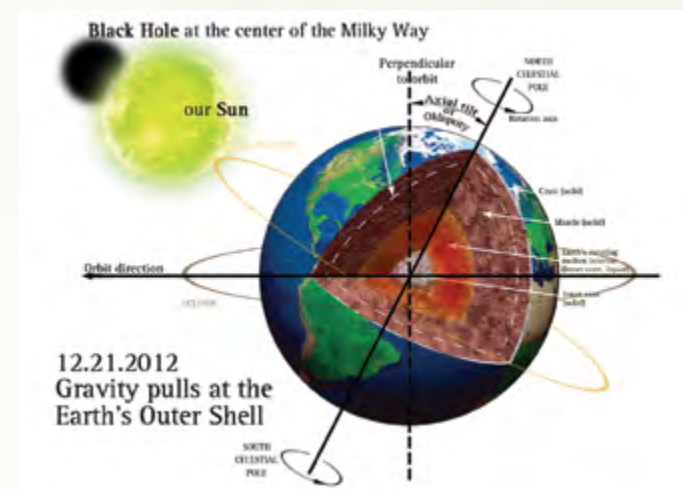

Modern Views on Pole Shifts

In the 1930s, Edgar Cayce was channeling answers for a geologist when, in the middle of a question, Cayce stopped and said something like, "You know, there's something a little more important going on with the Earth that maybe you should know about," and started talking about how the poles of the Earth are going to shift soon. He said the year it would happen would be the winter of 1998, but things have changed since then in a psychically unpredictable manner. The poles still may shift, but then again, they may do it in a way slightly different from Cayce's prediction. We do have free will, and we can change the fate of the world simply through our being. Edgar Cayce was an extraordinary human. He was a man people listened to when he spoke. The statement by Cayce that the poles were going to produce Magnetic Flow Changes.

The idealized lines of magnetic flow that come out in a torus around the Earth are not what geologists have found. The reality is that the magnetic lines look rather like straight weaving patterns. They're fixed, but they're not precise in that idealized kind of way. And there are certain areas where they're stronger and other areas where they're weaker. These lines normally do not move, but because the field is getting so weak, they are beginning to move and change. The birds, animals and fish, and the dolphins and whales and other creatures use these magnetic lines for their migration patterns.

So if the magnetic lines change, their migration patterns go off, which is what we're seeing all over

the world right now. Birds are flying to places they're not supposed to be, and whales are beaching themselves on land, where it's supposed to be water as far as they're concerned. They're simply following the magnetic line they've followed for centuries, and they're running into land that wasn't on that line before.

When these magnetic fields pass through zero point and completely change-which they may do very soon-we'll have another subject to talk about, about what happens then. You see, some believe your very memory is tied to those fields. They surmise that You can't remember anything without these magnetic fields. In addition, your emotional body is tied powerfully to the magnetic fields, and if they change, your emotional body is radically affected. It's easy to understand that the Moon affects the tides of the world through the pull of gravity.

We also know that the magnetic fields of the Earth are slightly affected by the phases of the Moon. When the Moon is full and passes overhead, we get a slight bulge and change in the magnetic field of the Earth. Just look at what happens in big cities during a full moon. The day before, the day of, and the day after the full moon, we have more rapes and murders and killings and weirdness of this nature than we do for the rest of the entire month. The police blotter of any major city will verify that.

Why? Because these fields especially affect people who are right on the edge of emotional instability, who are barely able to cope during normal times. They're right on the edge, then the Moon comes along and moves the magnetic field just a little bit, and the person experiences an emotional dip and does things he or she normally wouldn't do.

So imagine what would happen if the geomagnetic field of the Earth starts destabilizing. I heard in October 1993 from someone who's involved in aviation that in the last two weeks of September, major landing strips had to recalibrate their guidance systems because the magnetic fields made a unilateral shift all over the planet. It seemed to be temporary, lasting about two weeks. At that time you might have remembered an incredible emotional outburst within yourself and people around you. In my world I'm on the phone with people from all over the world. People were freaking out everywhere.

That's why I suspected that maybe what I heard might really be true. If it is true, then we are beginning to proceed almost certainly into to shift in the near future was almost unbelievable by most of the world. But because it was Edgar Cayce predicting this outrageous event, scientists and other interested persons began to study the possibility. Geologists would not believe his statement because they thought it would probably be millions or hundreds of millions of years between pole shifts, that this kind of change took a very long time. But because of Cayce's prediction, certain scientists began to search anyway. A string of major pieces of evidence came forth that lent tremendous weight to what Cayce was saying, and they have now changed the world's view on this subject.

The scientists suspected that if there were a change in the physical poles, then there would also be a change in the magnetic poles. One of the ways they decided to study this possibility was to examine the ancient lava beds of the world. This started taking place, I believe, in the 1950s or early '60s. They wanted to study lava beds because (1) they figured there would be tremendous volcanic action if such a shift took place, and (2) lava has a characteristic that could verify and date previous magnetic pole shifts.

Start the path to peak performance with
SCIO
at home

The SCIO can be prescribed for HOME USE to help your children with autism, attention difficulties, superlearning, sports, injury, pain, relaxation....



Home Use of **SCIO**

Monthly rental fees can be as low as
350 Euro a month.
Contact your SCIO therapist for
information...

If you need more information on the SCIO
and purchase/rental details please get in touch with us

Maitreya Kft.
tel: +3613036043 | web: www.qxsubspace.com | e-mail: info@qxsubspace.com

Iron Pilings and Core Samples

Iron pilings are found in most lava, and these pilings have a different melting point than the lava itself. The pilings harden while the lava is still flowing and, being iron, line up with the magnetic poles. Through this observation, geologists can see exactly where the magnetic poles were at the time the lava hardened. They needed to get samples from only three locations to be able to triangulate and know exactly where the magnetic north pole was at the time the pilings hardened. Then, of course, they could radiocarbon-date it, which was the best they could do back in those days. There were other approaches to this problem, which we will look at in a moment.

So they discovered an earlier magnetic north pole that was not where it is now but a long way away, centered in Hawaii. That last shift took place right at the upper oval—a little less than 13,000 years ago. They then did another test and found that the poles had shifted before that at the lower oval. This opened up a whole new area of investigation into the Earth's magnetism.

The Geological Society of America published a summary of findings gathered from ocean-floor core samples (*Geology* 11:9, September 1983). The samples were six inches in diameter and eleven feet long, and the researchers analyzed the sediment. They discovered that sometimes the poles simply reverse themselves. The north becomes the south and the south becomes the north. This was another thing Edgar Cayce talked about that people had a hard time believing. But when they analyzed these core samples, they found it was true.

Going back hundreds of millions of years, they discovered a cycle where the magnetic north pole would remain in place for a long time—then in a single day, less than 24 hours, magnetic north switched to the south. It stayed that way for a long time, then switched again. But toward the ends However, someone has offered another theory, one which even Albert Einstein considered seriously, that holds a possible answer to the equations that unbelieving scientists have used. His name is Charles Hapgood. He, and other scientists who worked with him, discovered at least two layers of unusual rock underneath the Earth's crust which liquefy under certain conditions.

Other scientists have demonstrated this in laboratories where they've put the same kind of rock into a miniature Earth and duplicated the conditions of the inner earth. From this experiment, they found that the surface or crust of the Earth can slip over the main mass of the Earth, which continues its rotation as if nothing had happened. It's a fact. It can happen, but of course we do not know if it will actually happen in real time. They don't know the specifics of how this would work—such as what trigger could cause this slippage. Charles Hapgood wrote two books, *Earth's Shifting Crust* and *The Path of the Pole*, that will probably eventually change our view of our world dramatically.

Albert Einstein wrote the foreword to Charles Hapgood's first book, ~ *Earth's Shifting Crust*. I feel it is important enough to reprint here directly: I frequently receive communications from people who wish to consult me concerning their unpublished ideas. It goes without saying that these ideas are very seldom possessed of scientific validity. The very first communication, however, that I received from Mr. Hapgood electrified me. His idea is original, of great simplicity, and—if it continues to prove itself—of great importance to everything that is related to the history of the earth's surface. The author has not confined himself to a simple presentation of this idea.

He has also set forth, cautiously and comprehensively, the extraordinarily rich material that supports his displacement theory. I think that this rather astonishing, even fascinating, idea deserves the serious attention of anyone who concerns himself with the theory of the earth's development. It is a given that Albert Einstein was one of the most brilliant humans who has ever lived, yet few geologists even yet believe such an outrageous theory. Only in more recent times has proof begun to accumulate that such things could be true. The same scientific world didn't believe Mr. Einstein either when he said how much energy was contained within a very small amount of matter.

It is my belief that the trigger to the pole shift is connected with the geomagnetism of the Earth. This would take a long time to explain, which I am not prepared to do here at this time. What is known is that for the last 500 years the Earth's magnetic field has been continually weakening, and in the last few years it has been doing absolutely bizarre things. According to Gregg Braden in *Awakening to Zero Point: The Collective Initiation*, the Earth's magnetic field actually began to weaken about 2000 years ago. Then around 500 years ago, the weakening really began to accelerate. (Could it be 520 years? This would match the Mayan Calendar, which predicted a huge change at that time.) In recent times the magnetic field is making unheard-of changes.

Magnetic Flow Changes

The idealized lines of magnetic flow you see coming out in a torus around the Earth are not what geologists have found. The reality is that the magnetic lines look rather like straight weaving patterns. They're fixed, but they're not precise in that idealized kind of way.

And there are certain areas where they're stronger and other areas where they're weaker. These lines normally do not move, but because the field is getting so weak, they are beginning to move and change. The birds, animals and fish, and the dolphins and whales and other creatures use these magnetic lines for their migration patterns. So if the magnetic lines change, their migration patterns go off, which is what we're seeing all over the world right now. Birds are flying to places they're not supposed to be, and whales are beaching themselves on land, where it's supposed to be water as far as they're concerned. They're simply following the magnetic line they've followed for centuries, and they're running into land that wasn't on that line before.

When these magnetic fields pass through zero point and completely change—which they may do very soon—we'll have another subject to talk about, about what happens then. You see, we believe your very memory is tied to those fields. You can't remember anything without these magnetic fields. In addition, your emotional body is tied powerfully to the magnetic fields, and if they change, your emotional body is radically affected. It's easy to understand that the Moon affects the tides of the world through the pull of gravity. We also know that the magnetic fields of the Earth are slightly affected by the phases of the Moon. When the Moon is full and passes overhead, we get a slight bulge and change in the magnetic field of the Earth. Just look at what happens in big cities during a full moon. The day before, the day of, and the day after the full moon, we have more rapes and murders and killings and weirdness of this nature than we do for the rest of the entire month. The police blotter of any major city will verify that. Why? Because these fields especially affect people who are right on the edge of emotional instability, who are barely able to cope during normal times. They're right on the edge, then the Moon comes along and moves

the magnetic field just a little bit, and the person experiences an emotional dip and does things he or she normally wouldn't do. So imagine what would happen if the geomagnetic field of the Earth starts destabilizing. I heard in October 1993 from someone who's involved in aviation that in the last two weeks of September, major landing strips had to recalibrate their guidance systems because the magnetic fields made a unilateral shift all over the planet. It seemed to be temporary, lasting about two weeks. At that time you might have remembered an incredible emotional outburst within yourself and people around you. In my world I'm on the phone with people from all over the world. People were freaking out everywhere. That's why I suspected that maybe what I heard might really be true. If it is true, then we are beginning to proceed almost certainly into the next phase of this work. These breakdowns in the magnetic field of the Earth will begin to come closer and closer together until there is a total collapse of the field and a shifting of the poles. This is one of the signs of the very end times.

There's no reason to get into fear about any of this. Even though what's happening is unusual, we've all been through these kinds of things many, many times before. This is not unusual for you, though most of you have very little memory of it.

When you actually start going through the dimensional shift and get into the feel of it, you'll say, "Oh, yeah, I remember this now. Here we are, going through this birthing again." So it's not a big deal, yet it is. You came from somewhere else when you were born as a baby, right?

You came from some other dimension and you passed through a void and came out through the womb to Earth. You traveled this path before, and we're about to do a similar kind of thing, only it's a really unusual one this time. There's no reason to fear it when you know all of it and remember who you are. In fact, what's occurring is extremely positive. It's very, very beautiful.

Harmonic and Disharmonic Levels of Consciousness

The Sanskrit literature talks about how when we approach the lower oval in the precession, we become aware of electrical energies. We can fly in the sky. We can do many unusual things. The world becomes extremely unstable, and in a single day we get rid of the old way of viewing the world and make a huge transformation in consciousness. But as we approach this transformation, given the particular level of consciousness we have, we tend to destroy everything we touch. It's a natural part of who we are. We're not doing anything wrong; it's just the way we are. We're doing it exactly right. We destroy everything, we cause every thing to go into disharmony. I'll be talking about this later, but I think it would be appropriate to tell you this much now: On Earth, according to Thoth, there are five totally different steps or levels of life that each human is going to pass through.

When we reach the fifth level, we will make a transformation that transcends known life itself. That's the normal pattern. Each one of these levels of consciousness has many aspects that are different from the other levels. First, they have different chromosome levels. The first level of human consciousness has $42 + 2$ chromosomes; the second level has $44 + 2$ chromosomes; the third one has $46 + 2$; the fourth, $48 + 2$; and finally $50 + 2$. Each level of human consciousness has a different body height associated with it. (This might sound kind of funny if you've never heard it before.) The first level of $42 + 2$ has a range of height somewhere between four and maybe six feet. The people who fall into that category specifically



THE
Angel
is here to give Renaissance,
to bring light to the darkness...

Dark Ages
This current era will not be known to history as
the Dark Ages but the Pitch Black Ages

...when the 250 richest families in the world control over 80% of the wealth and over 2.5 billion people live in abject poverty. The middle class is lead to believe they have an opportunity for happiness, but they are overly manipulated by the ultra rich. The ultra rich control the minds of the masses thru the media. They can get them to buy anything, fight for any stupid reason, hate their neighbor, take any pill, swallow any lie, believe any sales pitch. The celebrity worship culture drives them to revere shallow beauty over intellectual compassion.

The people have forgotten the teachings of Jesus and all of the wise religious masters. They fight for peace, fuck for chastity, use blood and mud to clean a country, spend to save, use mind altering drugs to steady the mind, use SINthetic medicines because the profit is greater than the natural. The ludicrous hypocritical ignorance eclipses logic and reason. And anyone that is different or thinks different must be sick.

Over 20% of the world's children go to tremendously inferior schools and thus have little if any chance of happiness. War are started over lies. Profits are more important than people. The hypocrisy of letting cigarettes be given to children, while stopping sales of vitamins and healthy herbals, is just one ludicrous example of a litany of farcical illogical beliefs that at one level or another make money. Money the greatest drug has become the highest God to many. Greed has replaced honor, hate has replaced love, and everyone has someone they want to kill.

Wars based on Lies, a World Financial Crisis leaving multi millions homeless, the leading cause of death in pregnant women is murder, weapons sales at a all time high, one person in three dying from smoking, synthetic drugs killing millions, scientists, legislators, officials are bought like candy, Global warming out of control, a self interest media controlled by a few, the world growing more and more stupid, the rich grow richer the poor poorer more than ever, a group of petty minded biased regulators under service of the Ultra Rich, greed anger arrogance and the delusions of false belief all propagated by the Ultra Rich.

This is indeed the Darkest of Ages.

are the Aborigines in Australia, and I believe that certain tribes in Africa and South America also do.

The second level of consciousness has 44 + 2 chromosomes, and that's us. Our band of height is about five to seven feet. We're a little taller than the first group. The third level's height goes up considerably. The 46 + 2 chromosome level interrupts the Reality through what you could term unity or Christ consciousness. That range of height is from about ten to sixteen feet tall.

Then there's another range for the fourth level of consciousness-the 48 + 2s-who have a height of about 30 to 35 feet. The final band, the perfected human, is between 50 and 60 feet tall. They have 52 chromosomes. I suspect that the reason there are 52 cards in a deck is related to those 52 chromosomes of the potential of man. For those of you who are Hebrew, you might remember that Metatron, the perfect man-that which we will become-was blue and 55 feet tall. (We'll talk about this again when we get into the subject of Egypt.)

There are states between the consciousness levels, like Down syndrome, for example. Down syndrome happens when a person transitions from this second level of consciousness, which we are on, into the third level, but didn't quite make it. The person didn't get all the instructions right, and where he almost always fails is in the left-brain instructional aspect of the chromosomes. A Down syndrome person has 45 + 2 chromosomes-he got one of them, but not the other. He or she got the emotional one-the heart one-all right. If you know any Down syndrome children, they are pure love, but they don't understand how to make the transition into the third level of human consciousness. They are still learning. The second and fourth levels of consciousness are Disharmonic, and the first, third and fifth levels are harmonic. You'll understand this when we see it in the geometries. When you look at human consciousness from a geometrical point of view, you can see the harmonic levels, and you can see that the Disharmonic levels are simply out of balance. That's where we are right now-out of balance. These Disharmonic levels are absolutely necessary. You can't get from level one to level three without passing through level two. But two is a totally Disharmonic consciousness. Does not chaos bring change?

Whenever a consciousness gets into the second or fourth level, it knows it can be there for only a short time. These levels are used as stepping stones-like a stone in the middle of a river, one you jump on and get off of as soon as you can to get to the other side. You don't hang out there, because if you do, you fall in. If we were to hang out here on Earth even just a little bit longer, we would destroy our planet. We would destroy it by just being who we are. Yet we are a sacred and necessary step in evolution. We are a bridge to another world. And we are living this bridge by just being alive in this incredible time.

The Darker Side of Our Present and Past

We are about to enter negative subjects for a bit. You could say, "There he goes getting into that fear stuff just after he said not to get into fear," but I want us to observe all the facets, both positive and negative, of life here on planet Earth. I don't want to look at only the positive ones; I want you to see the whole picture. And when you look at the whole picture, both the good and the bad, you'll see that the chaos is just part of the truth and part of the birth. A phenomenal change in human consciousness is occurring at this moment, though if you take any tiny segment of what's happening or look out in the world and see all the wars, famines and human emotional garbage that's filling our newspapers, the future does



"It is difficult to get a man to understand something that when his salary depends on him not understanding it"

Upton Sinclair

"A man can forget his father's Face but intimately remember his father's Property"

Machiavelli

"Earth provides for all of Man's needs but not for Man's Greed"

Mahatma Gandhi

"The Mind must be disciplined to Resist Greed, to Thoughtfully Consider Anger, and to Challenge and Explore False Beliefs. This must be done to even Start to build the Powers of the MIND. Small minded petty bureaucrats do not have the ability to do this, so they attack Great Spirits"

Desiré Delicious Dubounet

"A Greedy Man can Twist, Rationalize, Justify, Distort, Excuse, Contort, Disfigure, or Explain any Thought, Memory, Action, Experience, Idea, Position, Belief, Trust, Confidence, Contract, Agreement, or anything to Maintain or Warrant whatever makes him money. And OH, by the way, it can change in an hour to the exact opposite point of view, if Greed calls for it"

Desiré Dubounet

not look good. But when you get the whole image of life, you'll see that beyond all the negative, there's something much greater and vast and sacred and holy occurring at this moment in history. It becomes clear: Life is whole, complete and perfect now! Our Endangered Earth However, the most conservative scientists in the world that I can find don't give our planet more than 50 years-50! The most conservative scientists on the planet say there will be no life or almost none on this planet within 50 years if we continue the way we're going. Many scientists give us only three or more years; some of them give us ten. Most don't give us more than fifteen years. It depends on who you read. Even if it were a hundred or a thousand years, would that be acceptable?

You would not be hearing any of this information today if it were not for some changes in our government that have taken place in the last eight years that have allowed this information to be presented. Although they're not allowing you to know everything, there has been a change in the powers that be where they're beginning to cooperate with life.

They simply can't In 1992 the world nations met at an "Earth Summit" in Rio de Janeiro to discuss Earth's environmental problems. The largest gathering of heads of state in the history of the world was called because of the danger of losing our planet. Most of the world came, but the United States, the largest polluter in the world, didn't even want to participate. It was obvious that the political administration felt that money, jobs and the economy were more important than whether the Earth survived. Five months later, on November 18, 1992, a document titled "World Scientists'

Warning to Humanity" was released. More than 1600 senior scientists from 71 countries, including over half of all living Nobel Prize winners, signed this document. It was the most alarming warning the world has ever received from such a powerful body of researchers.

You would think that this document would hold great credibility and that the world would carefully listen.

It began: "Human beings and the natural world are on a collision course. Human activities inflict harsh and often irreversible damage on the environment and on critical resources. If not checked, many of our current practices put at serious risk the future that we wish for human society and the plant and animal kingdoms, and may so alter the living world that it will be unable to sustain life in the manner that we know. Instead of quitting, is not this the time to focus.' Human consciousness is powerful. We will know what to do. We are more than the ordinary world knows. Do you remember? Okay, now let's talk about the dark side. This is a January 2, 1989, issue of Time magazine.

In 1988 the secret government of the world decided to allow us to know some of what was going on around environmental problems. This was the first major publication on the subject in the world. Time magazine declared the Earth to be the "planet of the year." Instead of featuring a man or woman of the year, they broke away from their tradition. The entire magazine was devoted to our endangered Earth and its problems. If you were to read the problems as they were presented in 1989 and then read the problems as they're being presented in articles today, you'll realize that what they gave us in 1989 was a ultra-watered-down version of the truth. It wasn't even close. But at least it was a beginning for our world to see the truth about what we have done to Mother Earth.

We're going to discuss only four or five different problems the Earth has, though there are multiple

different scenarios going on. If any one of these scenarios were to break down, all life on the planet would eventually die. And at the moment they're all about to break down-it's just a matter of which one breaks down first. And whenever one system goes, then all the rest of them will go eventually, and that's it, there won't be any more human life. It will be over with, and we'll end up just like Mars or the dinosaurs. A few years ago, around the turn of this century, there were 30 million species of life forms on Earth-30 million different species of life. In 1993 there were about 15 million. It took billions of years to create these life forms, and in less than a blink of an eye, a mere hundred years, half of the life on this dear Earth is dead. Around thirty species a minute are now becoming extinct somewhere. If you were to watch this planet from space, it would appear to be dying very, very rapidly. Yet we're going on as though nothing's happening and everything's great. We're sticking money in the bank and driving our cars and just wiggling right on.

Yet from an honest point of view, we have a real life-and-death problem going on here on Earth, and few people seem to be really serious about it. When they tried to get the entire world to come together in Rio in the early '90s to discuss the worldwide environmental problem, our president didn't even want to go. Why not? Because the problems are so serious that if we were to fix them, another problem would happen that would be an even more serious problem, from the president's point of view:

We would be plunged into a worldwide financial breakdown, after which a large portion of the Earth's population would die from starvation and other problems. In essence, we cannot afford to repair the environment. On the other side of the coin, can we afford not to?

Dying Oceans

It was in the August 1, 1988, issue that Time magazine focused its attention on the oceans and what was happening there. Jacques Cousteau wrote a book about this around 1978. He was a very respected person, but when he wrote this book, he lost credibility in scientific circles because he made a statement that nobody could believe. He founded his statements on pure science, but people simply could not or would not accept the truth. Specifically, he said that the Mediterranean Sea would be a dead body of water by the end of 1990 and that the Atlantic Ocean would also be dead by the turn of the century. People thought, "This guy's nuts. It's never going to happen."

Well, it is happening. The Mediterranean Sea is now somewhere around 95 percent dead. It's not 100 percent, so he was not exactly right.

Nevertheless, it's still going to be a dead sea if people continue to live the way they do. And the Atlantic Ocean is rapidly doing the same. Maybe it won't happen in the year 2000, but it will happen very soon after that. Unless something changes dramatically, it will die-no fish, no dolphins, no life in the Atlantic. We can't live without the oceans. The bottom of the food chain, the plankton, will be gone, and if they go, we go. When we don't take this seriously, it's like saying, "Well, I don't really need my heart."

This is a major component in the ecosystem on Earth, and it's going fast. This is not debatable, this is scientific fact. The only part that is debatable is when. It is really happening. Nobody believed it would happen because they just couldn't accept this truth.

New York City, for instance, has pipes that go twenty miles out and dump all their human feces into

the oceans. They figured, Well, the oceans will take care of it. But for the last 60 years or so it's been building up into a huge mountain. Now, there's a mountain range of shit out in the ocean that is moving toward New York City. It's now up against and actually coming into the harbor, and they don't know what to do about it. It would take more money than New York has to fix it. This is the kind of foresight that we as humans have demonstrated. The human manure approaching New York is an Atlantic Ocean problem. However, the problem is not limited to the Atlantic or the Mediterranean. The Pacific Ocean is Earth's largest body of water, and it will probably take longer, but it is also having tremendous problems, especially in certain areas. The red tide is the first deadly sign of the pollution. It's an algae that destroys everything that lives underneath it-it kills everything.

And these red tides are beginning to-sweep all over, especially around Japan where there's so much pollution. We've made lots of mistakes all over the Earth because we don't have the consciousness to know how to live in harmony with our own body, Mother Earth. This is like a symptom of cancer or some other dreaded disease. Fundamental changes are urgent if we are to avoid the collision our present course will bring about."The warning document then began to list the crises: polluted water, oceans, soil, atmosphere, diminishing; plant and animal species and human overpopulation. (More than half of the life on this planet is now extinct and continuing to die.)

Ozone

Here's another problem. Figure 3-4 shows the ozone hole above the South Pole. Ozone forms a thin layer about six feet thick. It's a really thin, fragile layer, a living layer that's constantly being rebuilt. We know very little about it, though we know more than we would if it weren't for the UV light (ultraviolet light, band C) that's coming through the holes right now. When they began to detect huge amounts of UV, especially as shown here coming into the South Pole, they couldn't understand how there got to be so much, because their computers didn't show it.

Then they found out that their software programming was set up in such a way as to override this sort of thing.

After they reprogrammed their software, they found out the hole was really there. This was some years ago. What they actually were looking for was chlorine monoxide, the molecule shown in the far right of Figure 3-5. They figured that the ozone hole is caused by various chemicals, one of which are CFCs. CFCs react with the ozone in such a way that when the chlorine connects with the ozone, the ozone molecule breaks apart, thus forming oxygen and chlorine monoxide. Scientists figured, given the speed they thought the CFCs were moving toward the ozone, that the chlorine monoxide up there would be about 30 times over normal, and they were very worried about it.

So the world governments tried to get the companies that were producing the CFCs-Freon and various other chemicals that cause this problem-to stop producing those products and find other answers. In reply, the companies all said in unison, "We're not doing it. That's a natural phenomenon. We have nothing to do with it." So the world governments had to prove in court that the companies were at fault, which they did. To get the proof they needed, for the first time in the history of the Earth every single country on the planet cooperated in a single venture. This had never happened before. They flew

highaltitude planes over the South Pole for about two years collecting data, and they finally came up with something that really scared them.

The destructive ingredient, chlorine monoxide, wasn't 30 times over normal-it was 500 times over normal and moving much faster than they had believed. This article came out in 1992, I believe. It first says that the EPA predicts 200,000 more skin cancer deaths from the ozone hole. But up in the right column they have a tiny section reporting that the EPA says that the fatality estimates they had originally given were incorrect, and are ≥ 1 times worse than they had estimated. Twenty-one times-now, that's a lot. It's not like saying, "Well, it's a little bit more."

This is what the government has been doing; they give out little bits of information in little articles that don't tell you much. They don't make it a big deal. By law they have to announce it, so they announce it in little articles and then let it go. Then they up the ante in another insignificant article- as in this article here, for example, where they said the danger was 21 times higher than their first estimate; then two weeks later the same paper comes back and says, "Oh, by the way, we were off two weeks ago, it's actually double that." Well, double doesn't sound like much-except that means it went from 21 times to 42 times worse than their first report, which is an incredible amount. If the truth had been told in the first place, it would have sounded terrible and created fear. This is what's been going on all over the world for a long time. The only way the world governments know how to deal with the situation is by letting it out little by little, admitting to more and more and more. They know members of the world's scientific community, hereby warn all humanity of what lies ahead.

A great change in our stewardship of the Earth and life on it is required if vast human misery is to be avoided and our global home on this planet is not to be irretrievably mutilated." Yet most of the world rejected this statement even though it was created by one of the most respected scientific bodies ever assembled on Earth. You would think we would pause and say, "If this is true, what can we do? Let's drop everything and do whatever is necessary."

But the governments know that if we are to avert this crisis, we must change the way we live, and that would not be politically comfortable. No politician wants to be the one to introduce this unpopular change. To the governments, the economy would suffer and perhaps even collapse if we were to stop polluting. So it has become a war of money against life-terrible but true.

The New York Times and the Washington Post, two of our most respected leaders in reporting the news, rejected this document as not newsworthy. This gives you a good idea of the importance we place on the planet itself. (You can read about all this and much more in *The Sacred Balance, Rediscovering Our Place in Nature* by David Suzuki. Think for a moment: This warning document gives us "one or a few more decades" to avert this crisis-and it was written seven years ago.

This Earth is billions of years old. It has taken millions of years for mankind to reach this level of awareness, yet in a mere 10 to 30 years, a geological blink of an eye, if we do not act in a positive manner, we may become "irretrievably mutilated." The word "extinct" was avoided, but we all know it is a possibility. They have to tell you the truth (for reasons you'll learn later), but they're afraid to say we're in real trouble.

They just say, "Well, it's not so bad, but it's getting worse," and statements like this. Well, not only is



It is Time to ReBoot the System. It is Time for a Change. It is Time to ReExamine everything. ReExamine all of our Beliefs, Ideas, Values.

This must be done very carefully to preserve our Culture and prompt our Society.

2012 is coming, and we must learn to first accept the powers of the mind and then master them to prevent the catastrophe. To get to a thousand Years of peace and harmony, we will all need to grow beyond the evils of our society (Greed, Anger, Hate, Avarice, Xenophobia, Delusion of False Beliefs, Arrogance, Selfish Conceit, and Hypocrisy). The Angel has shown us the way, created a new path to follow, and designed a way to get to the Prophesied Millennium.

there an ozone hole at the South Pole, but there's one at the North Pole now, and the rest of the ozone is Swiss cheese. In 1991 or 1992 there was a major television production on the ozone hole. It brought together all the major people who were involved in studying this, and they discussed all the pros and cons. They interviewed a particular husband-and-wife team-I don't have their names, but they also wrote a book on this very subject several years ago, predicting that the ozone hole was going to happen. Before we even knew about it, they had studied it all, according to this program. And the ozone is now undergoing changes exactly like they said it would and at exactly the rate they predicted.

This couple was brought on TV as the experts, and the interviewer asked, "Well, what do you think?" This interviewer was kind of puppylike, asking, "What are we going to do? You guys know everything about it, so what are we going to do about the ozone?" The husband said, "There's nothing we can do." I don't believe they like to hear statements like that on major channels. The interviewer asked, "What do you mean, there's nothing we can do?" The authors said, "Well, suppose we get the entire world to cooperate?"-which is the first thing that would have to happen, and we can't even do that now, some fifteen years later! "Suppose we do get the entire planet to say, 'Okay, we'll stop it all today. No more of these chemicals that are destroying the ozone will ever be used again.'"

The author said, "Okay, suppose we did it. Suppose we got the whole world to stop. That still doesn't solve the problem." And the interviewer said, "What do you mean? Wouldn't it just heal itself?" The author answered, "No, because the spray can that you sprayed yesterday sits on the surface of the ground and the CFCs take 15 to 20 years to rise to the ozone layer. This layer that's slowly rising and eating the ozone will continue for 15 to 20 years even if we stop everything today. And it will continue to eat it faster and faster, because we've used more and more of these chemicals in recent years." He said, "There won't even be an ozone layer"-I think he said in ten years. "I see no solution at all." "If we lose our ozone, we're in big trouble. All the animals of the world will go blind. You won't be able to go out during daytime without a spacesuit on, meaning every square inch of your body will have to be covered special UV goggles and everything. In a short time the UV light would eventually kill you. And we're rapidly approaching that. If you don't think so, read what the Wall Street Journal reported in January 1993.

The journal was reporting what's happening in southern Chile, which is close to the ozone hole at the South Pole. The animals are starting to go blind. The people who live there have thick, dark skin, and they've spent all their lives outside, but now they're getting burned in the course of everyday living. And it's spreading north from Chile and starting to happen everywhere. Because of the Swiss cheese aspect of the entire ozone layer, places all over the Earth are becoming unsafe.

You never know where these spots are going to be because they move over the face of the Earth from year to year. This ozone problem is happening now, not tomorrow or later or maybe someday. It's occurring at this very minute. Given another few years, we're going to be in really serious trouble.

They knew about the ozone problem at least as far back as when Reagan was president. When the environmental agencies asked him, "What will we do about this ozone problem?", Reagan was really flippant about it. He said something like, "Aw, we'll just issue raincoats and dark sunglasses to solve the problem." Just like that, what the heck? We're talking about our very lives here, our very existence, and the governments are continuing as though it doesn't even matter.

PROJECT NAHINGA

“The Angel that comes to save the planet”

In African Bantu the word for the Angel coming from Heaven to the Earth to save its people is NaHinga. This name was given to Desiré for her work on AIDS. Desiré kicked off project NaHinga in early 2005 in Africa. Desiré is a citizen of Mozambique and is a diplomatic liaison for the country. All because of her work on healing. She taught the natural healers, the Sangoma, to make remedies for AIDS and how to use simple energetic medicine.

Project NaHinga was a multi million dollar task financed solely by Desiré for the purpose of healing the planet.



The Strecker Memorandum on AIDS

AIDS possible scenario

For decades persons have been hired by the governments to do research in biological warfare. Person's were hired to discover viruses like the AIDS virus. Some proud such worker was really happy when he first combined DNA fragments and made the AIDS virus. I'm sure he thought he deserved a gold star not the lead pellet he got for his work. His job was to design it, not to determine it's fate. The first test of the virus were in small towns in Haiti and Africa. But during the test one of the subjects got free. This is a demonstration of the stupidity of the Martian type mind. To think that a biowarfare agent could be contained is lubricious. I suggest you try to find the Strecker Memorandum material if you haven't read it or watched the video. The governments are really trying to suppress it. Dr. Strecker made a video memorandum of what he believed happened around AIDS. He is a brilliant person. He has worked with retro viruses and is an expert on this subject. He showed the video on television, and the governments threatened him. They allegedly killed his brother and the senator who was sponsoring it. But they didn't get Strecker-that would have been too obvious, I guess. Dr. Strecker has distributed many of his videos. He got them out to the world, though you don't hear about it anymore.

Dr. Strecker shows on his film how the United Nations was trying to solve an environmental problem. They knew that the biggest environmental problem in the entire world was the human population, and at the rate it was going, the world would double its population by 2010 or 2012. But because of what the Chinese did, allowing only one child per couple, and other strenuous work around the world, they slowed it down. But they believe that it's still going to happen. It is now estimated that somewhere around 2014 the world population will have doubled. If that happens, computer models have shown that all life on Earth will die or wish they were dead, according to the United Nations, because we can barely keep it together with almost six billion people. Can you imagine what it would be like with 11 to 12 billion people in the world? There's just no way, at least under the present system.

So, if you were in the United Nations and knew this potential disaster was going to take place and had to make a decision, what would you do. I'm not judging the people who did this-just put yourself in their position of great power. You see that the Earth is coming to a solid wall, that it's going to be totally destroyed if something is not changed. So they made a decision-and

Dr. Strecker showed the memorandum right on television. The United Nations decided that, rather than hit that wall of 11 billion people, right then and there they were going to create a virus or a disease that would kill specifically three-quarters of the people on Earth. In other words, instead of increasing to 11 billion, they wanted to reduce the current population by three-quarters. He showed the actual U.N. document that planned to eliminate three-quarters of the world's population.

Dr. Strecker showed scientifically exactly how the U.N. did it. They took a virus from a sheep and a virus from a cow and blended them together in a certain way to make the AIDS virus. But before they ever distributed it, they also made a cure for it. The governments have the cure right now, according to Dr. Strecker. The people who were doing this-and history will verify this-were obviously prejudiced, because they singled out two groups: the Blacks and the homosexuals.

In Haiti there was an epidemic of hepatitis B moving through the homosexual community, and they all

needed to be injected with the hepatitis B vaccine. So U.N. agents took the AIDS virus, put it in the hepatitis B vaccine and injected it into everyone. That's how the virus started, according to Dr. Strecker. The other evidence that this is true is that throughout the rest of the world, the virus was not given exclusively to homosexuals. In Africa, where at least 75 million people have AIDS, the ratio of male to female infection is almost exactly 50-50, from the beginning until now. Only in Haiti, and eventually in the United States, did it spread almost exclusively through the homosexual population. If you look at the figures for this country, females are now getting AIDS faster than anyone else. Soon nature will balance it out, and you'll see exactly the same thing you see everywhere else around the world, which is that equal numbers of males and females have AIDS. It isn't a gay disease at all-it has nothing to do with it.

It has to do with the prejudice of the people who created it.

According to Dr. Strecker, the World Health Organization, which has been instrumental in creating this disease, has also been concerned about other diseases-and so have doctors pretty much everywhere. For instance, let's take cancer: Doctors have been concerned that someday cancer will become contagious, not by pollution or foods or things like this, but that it will become airborne or waterborne, like a cold. You'd just walk by somebody with cancer and you'd get it. But the number of different kinds of cancer viruses is so small that the likelihood of that ever happening is pretty slim. It still could happen, but it's not likely. But for AIDS, there are 9000 to the 4th power or 6, 561, 000, 000, 000 totally different kinds of AIDS viruses that's a huge number. And every time someone gets AIDS, a brandnew virus is created, one that has never been seen before, ever. This means that it's inevitable, mathematically speaking-it's just a matter of time that AIDS will spread rapidly, just like a cold, throughout the world.

There is a story going around that the World Health Organization believes that this rapidly spreading form of AIDS may have already begun. Around 1990 or 1991 the WHO checked an African tribe of 1400 members, including everyone from little babies to old people, who obviously had all different kinds of sexual practices (you know, little babies aren't into sexual things), and they found that every single member, without exception, had AIDS. That's when the WHO announced secretly that the virus was ATLANTIS including over half of all living Nobel Prize winners, signed this document. It was the most alarming warning the world has ever received from such a powerful body of researchers. You would think that this document would hold great credibility and that the world would carefully listen.

It began: "Human beings and the natural world are on a collision course. Human activities inflict harsh and often irreversible damage on the environment and on critical resources. If not checked, many of our current practices put at serious risk the future that we wish for human society and the plant and animal kingdoms, and may so alter the living world that it will be unable to sustain life in the manner that we know. Let you know the full extent of the situation, because they believe that most of the world would just quit their jobs and say, the heck with everything, leading to complete chaos. Instead of quitting, is not this the time to focus." Human consciousness is powerful. We will know what to do.

We are more than the ordinary world knows. Do you remember? Okay, now let's talk about the dark side. This is a January 2, 1989, issue of Time magazine. In 1988 the secret government of the world decided to allow us to know some of what was going on around environmental problems. This was the first major publication on the subject in the world. Time magazine declared the Earth to be the "planet of the year." Instead of featuring a man or woman of the year, they broke away from their tradition. The



Spinal injury and pain

Using MTENS, and TVEP the SCIO can treat the spinal area for injury and pain.

Sending in an auto-focused sophisticated pulse different for each patient based on their personal electrical needs.

entire magazine was devoted to our endangered Earth and its problems. If you were to read the problems as they were presented in 1989 and then read the problems as they're being presented in articles today, you'll realize that what they gave us in 1989 was a ultra-watered-down version of the truth. It wasn't even close. But at least it was a beginning for our world to see the truth about what we have done to Mother Earth.

We're going to discuss only four or five different problems the Earth has, though there are multiple different scenarios going on. If any one of these scenarios were to break down, all life on the planet would eventually die.

And at the moment they're all about to break down-it's just a matter of which one breaks down first. And whenever one system goes, then all the rest of them will go eventually, and that's it, there won't be any more human life. It will be over with, and we'll end up just like Mars or the dinosaurs. A few years ago, around the turn of this century, there were 30 million species of life forms on Earth-30 million different species of life. In 1993 there were about 15 million. It took billions of years to create these life forms, and in less than a blink of an eye, a mere hundred years, half of the life on this dear Earth is dead. Around thirty species a minute are now becoming extinct somewhere. If you were to watch this planet from space, it would appear to be dying very, very rapidly. Yet we're going on as though nothing's happening and everything's great. We're sticking money in the bank and driving our cars and just wiggling right on.

Yet from an honest point of view, we have a real life-and-death problem going on here on Earth, and few people seem to be really serious about it. When they tried to get the entire world to come together in Rio in the early '90s to discuss the worldwide environmental problem, our president didn't even want to go. Why not? Because the problems are so serious that if we were to fix them, another problem would happen that would be an even more serious problem, from the president's point of view: We would be plunged into a worldwide financial breakdown, after which a large portion of the Earth's population would die from starvation and other problems. In essence, we cannot afford to repair the environment. On the other side of the coin, can we afford not to?

The Structure of the Human Brain

This circle represents a human head, looking down from above. The human brain is divided into two components, the left side and the right side.

The left side is more male and the right side is more female, and they are linked by the corpus callosum. According to Thoth, this is the nature of these two hemispheres: The left, male component sees everything absolutely logically-as it is, you might say. The right, female component is much more Concerned with experiencing something than understanding it.

The female and male perceptions are mirror images of each other-as if you had a mirror between them. If you had the word LOVE written into the male component, he would see it as shown. But the female sees its mirror image, also as shown. When the male looks at her way of perceiving, he says, "There's no logic here." She looks at him and says, "Where is the feeling?"

The brain is further divided into four lobes by another thin division.

The male side of the brain has a component behind it that reflects, or mirrors the front. There's another mirror image behind the female side that reflects what's in front of it. The male logical component has a totally experiential component behind it and the female experiential component has totally logical component behind it. It's as if there are four mirrors reflecting each other in these four possible ways. When we look at the geometries later, you'll see that the forward part in the male brain, the logical component, is based on the triangle and the square (in two dimensions) or the tetrahedron and the cube (in three dimensions).

The forward part in the female brain, the experiential component, is based on the triangle and the pentagon (in two dimensions) or the tetrahedron, the icosahedron and the dodecahedron (in three dimensions). There are also diagonal pathways connecting the left-front logical to the back-right logical, and the right-front experiential to the back-left experiential. Thus the mirror quality reflects side to side, front to back, and diagonal to diagonal. This is the way we're made up, according to Thoth.

Mars after the Lucifer Rebellion

According to Thoth, Mars looked much like Earth a little less than a million years ago. It was beautiful. It had oceans and water and trees and was just fantastic. But then something happened to them, and it had to do with a past "Lucifer rebellion." From the very beginning of this experiment we are in-and all of God's creation is an experiment-experiments similar to the Lucifer rebellion (if you want to call them rebellions) have been attempted four times. In other words, three other beings besides Lucifer attempted to do the same thing, and each time it resulted in utter chaos throughout the universe.

More than a million years ago, the Martians had joined the third rebellion, the third time that life decided to try this experiment. And the experiment failed dramatically. Planets everywhere were destroyed, and Mars was one of them. Life attempted to create a separate reality from God, which is the same thing that's going on now. In other words, a portion of life attempted to separate itself from all other life and create its own separate reality. Since everyone is God anyway, this is okay-you can do that. The only thing is, it never has worked so far. Nevertheless, they tried it again. When someone tries to separate from God, they sever their love connection with Reality. So when the Martians (and many others) created a separate reality, they cut the love bond-they disconnected the emotional body-and in so doing they became pure male, with little or no female within them. They were purely logical beings with no emotions. Like Mr. Spock in Star Trek, they were pure logic. What happened in Mars, and in thousands and thousands of other places, was that they ended up fighting all the time because there was no compassion, no love. Mars became a battleground that just kept going on and on and on, until finally it became clear that Mars was not going to survive. Eventually they blew their atmosphere away and destroyed the surface of their planet.

Before Mars was destroyed, they built huge tetrahedral pyramids, which you're going to see in photographs in the second volume. Then they built three-sided, four-sided, and five-sided pyramids, eventually building a complex that was able to create a synthetic Mer-Ka-Ba. You see, you can have a space-time vehicle that looks like a spaceship, or you can have certain other structures that do the same thing. They built a structure from which they were able to look ahead and behind in time and space to tremendous distances and time periods.

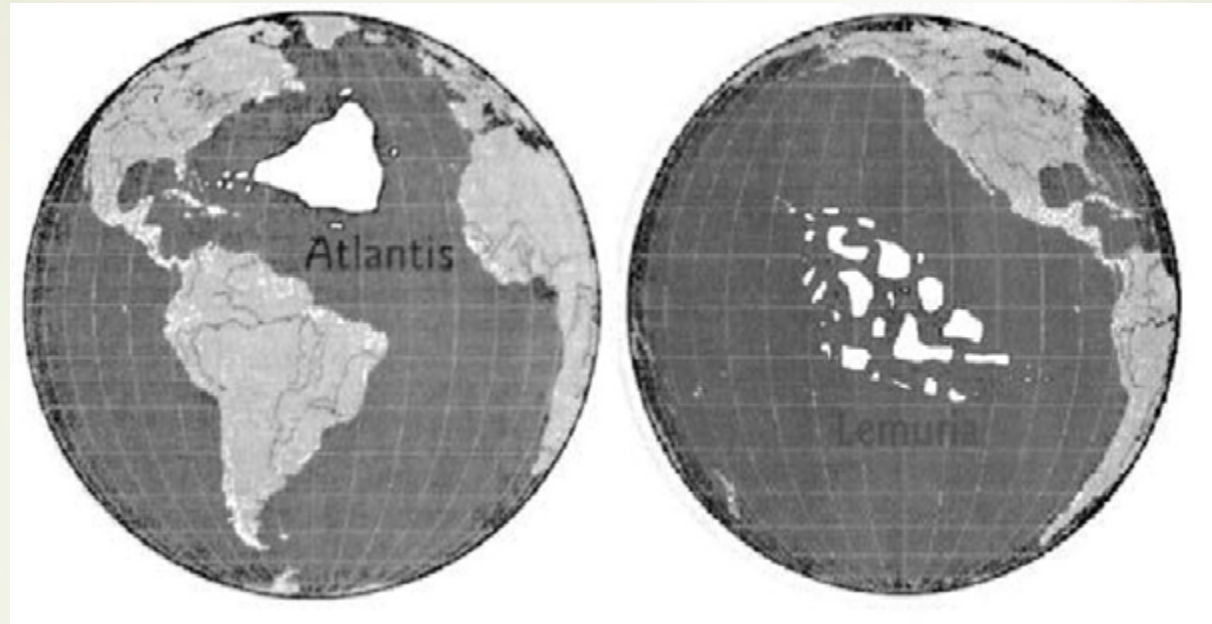

A small group of Martians tried to get away from Mars before it was destroyed, so they translated themselves into the future and found a perfect place to resettle before Mars was destroyed. That place was Earth, but it was about 65,000 years in our past. They saw that little vortex sitting there on Atlantis with nobody in it. They didn't ask permission. Being part of the rebellion, they didn't go through the normal procedure. They just said, "All right, let's do it." They stepped right into that vortex, and in so doing, they joined our evolutionary path.

Martians Rape the Human Child Consciousness and Take Over

There were only a few thousand of these Martians who actually used the time-space-dimension consciousness machine, or building. The very first thing they did when they arrived here on Earth was try to take control of Atlantis. They wanted to declare war and take over. However, they were vulnerable because of their small numbers and perhaps other reasons, so they couldn't do it. They were finally subdued by the Atlanteans/Lemurians. We were able to stop them from conquering us, but we could not send them back. By the time this took place in our evolutionary path, we were about the age of a 14-year-old girl. So what you had here was similar to a 14-year-old girl being taken over by a much older man, a 60- or 70- year-old man who simply forced himself on her. In other words, it was rape.

We were raped, we had no choice. The Martians just stepped in and said, "Like it or not, we're here." They didn't care what we thought or felt about it. It was really no different from what we in America did to the Native Americans.

Once the initial conflict was over, it was agreed that the Martians would try to understand this female thing they lacked, this emotional feeling, of which they had none at all. Things more or less settled down for a long time. But the Martians slowly began to implement their left-brain technology, which the Lemurians didn't know anything about. All the Lemurians knew was right-brain technology, which today

we know very little about. The QXCI is a variant of an ancient Lemurian device known as XXRROID. Psychotronic machines, dowsing rods and those kinds of things are also right-brain technologies. Many right-brain feminine technologies would astound you if you saw them in action. You can do absolutely anything that you can imagine with right-brain technology, just as you can with left-brain technology, if they are brought to their full potential. Professor Nelson was an ancient

Lemurian female priestess who transcended thru a right brain temporal worm hole device she created. Then for balance Nelson took male form in our culture. Using the Lemurian secrets Prof Nelson was able to design the QXCI and the PET technology. Our present society is dominated by left brained types.

The Martians kept putting out these left-brain inventions, one after another after another, until finally they changed the polarity of the evolutionary path because we began to "see" through the left brain, and we changed from female to male dominance. We changed the nature of who we were. The Martians gained control bit by bit, until eventually they controlled everything without a battle. They had all the money and all the power. The animosity between the Martians and the Lemurians-and I'm putting the Hebrews in with the Lemurians-never subsided, not even to the very end of Atlantis. They hated each other. The Lemurians, the feminine aspect, were basically shoved down and treated like inferiors. It was not a very loving situation. It was a marriage that the female component did not like, but I don't think the Martian males really cared if she liked it or not. It remained this way for a very long time, until approximately 26,000 years ago, when the next phase slowly began.

Minor Pole Shift and the Subsequent Debate

It was about 26,000 years ago when we had another minor pole shift and a small change in consciousness. This pole shift took place at the same point on the polar wobble called the precession of the equinoxes that we have now returned to. It wasn't much, though it has been recorded by science. The two small ovals on the cycle are where these changes always take place, and right now we're back at point A again. At the time of this pole shift, a piece of Atlantis, probably about half the size of Rhode Island, sank into the ocean. That caused a tremendous amount of fear in Atlantis, because they thought they were going to lose the whole continent, like what happened to Lemuria. By this time they had lost most of their ability to see into the future. They were shaking in their boots for a long time simply because they didn't know for sure what was going to happen. They were still afraid a hundred years later, then slowly this fear began to subside. It took over 200 years for them to feel safe again.

Atlantis was a little beyond the lower oval at A when they finally relaxed their fear about Earth changes. But the memory was still there. They were going along nicely for a while, then out of the blue approximately 13,000 to 16,000 years ago, a comet approached Earth. When this comet was still in deep space, the Atlanteans knew about it because they were more technologically advanced than we are now. They witnessed its approach. A great conflict began to occur in Atlantis. The Martians, who were in the minority even though they were in control, wanted to blow it out of the sky with their laser technology. But there was a huge movement amongst the Lemurian population against using the Martian left-brained technology. The feminine aspect said, "This comet is in divine order, and we should allow this to take place naturally. Let it hit the Earth. That is what's supposed to take place."

Of course, the Martians replied, "No! Let's blow it out of the sky. We have very little time, or we all will be killed." After lots of arguing, the Martians finally and reluctantly agreed to allow the comet to hit the Earth. When it arrived, it came screaming into the atmosphere, plunging into the Atlantic Ocean just off the western shore of Atlantis near where Charleston, South Carolina, is now, only it was on the bottom of the ocean then. The remnants of that comet are now scattered over four states. Science has definitely determined that it did hit there somewhere between 13,000 and 16,000 years ago. They're still finding pieces. Although most of the fragments were centered near Charleston, one of the two largest pieces actually struck the main body of Atlantis in its southwestern area. These left two huge holes in the floor of the Atlantic Ocean and could have been the true cause of the sinking of Atlantis. The actual sinking did not happen at that time, but took place at least several hundred years later.

The Martians' Fateful Decision

The pieces of the comet that crashed into the southwestern area of Atlantis happened to be right where the Martians were living, killing; a huge portion of their population. The Martians got hurt the worst by consenting; to allow the comet to come in. Well, that was too humiliating and painful for them. This was the beginning of a great loss of consciousness for Earth. What was about to take place was the seed for a bitter tree, the same tree we live by today. The Martians said, "It's all over. We are divorcing you. We're going to do whatever we want from now on. You can do whatever you want, but we're going to lead our own lives and try to control our own fate. And we're not going to listen to you ever again." You know this whole number. We've seen it in divorced families throughout the world. And the children? Look at our world! We are the children!

The Martians decided to take over the Earth, of course. Control, the Martian's primary interface with the Reality, rose to meet their anger. They began to create a building complex like the one they had constructed on Mars a long time earlier, in order to create a synthetic Mer-Ka-Ba once again. The only thing is, around 50,000 Earth years had passed since they had created one, and they didn't remember exactly how to do it-but they thought they did. So they built the buildings and began the experiment. That experiment is directly tied to a chain of Mer-Ka-Bas that began with the Mars experiments a little less than a million years before. Later, one was done here on Earth in 1913, another one in 1943 (called the Philadelphia Experiment), another one in 1983 (called the Montauk Experiment), and another one that, I believe, they're attempting to do this year (1993) near Bimini Island. These dates are windows of time that open up and are tied to the harmonics of the situation. The experiments must be timed to these windows in order to succeed.

If the Martians had succeeded in setting up a synthetic harmonic Mer-Ka-Ba, they would have had absolute control of the planet, if that was their intention. They would have been able to make anybody on the planet do anything they wanted, though eventually it would have meant their own demise. No higher-order being would place this kind of control on another if they truly understood the Reality.

Failure of the Martian Mer-Ka-Ba Attempt

The Martians built the buildings in Atlantis, set up the whole experiment, then threw their switch to begin the energy flow. Almost immediately they lost control of the experiment, like falling through space

and time. The degree of destruction was more horrible and sinful than I care to describe. In this Reality, you can hardly make a greater error than to create an out-of control synthetic Mer-Ka-Ba. What the experiment did was begin to rip open the lower-dimensional levels of the Earth-not the higher ones, but the lower ones. To give an analogy, the human body has membranes between different parts, such as in the heart, the stomach, the liver, the eyes and so on. If you took a knife and slit open your stomach, that's would be like ripping open the dimensional levels of the Earth. Various aspects are separated from other aspects of spirit by these dimensional membranes, and they're not meant to mix. You're not supposed to have blood in your stomach, but in your arteries. The purpose of a blood cell is different from that of a stomach cell. These Martians did something that almost killed the Earth. The environmental disaster we are experiencing today is nothing in comparison, though the problems we are having are a direct result of what we did long ago. With the right understanding and enough love, the environment could be repaired in a single day. But had this Martian experiment continued, it would have destroyed the Earth forever.

We would never have been able to use the Earth as a seed base again. The Martians made a very, very serious mistake. This out-of control Mer-Ka-Ba field, first of all, released a huge number of lower-dimensional spirits into the Earth's higher-dimensional planes. These spirits were forced into a world they did not understand or know, and were in total fear. They had to live-they had to have bodies-so they went right into people, hundreds of them into each person in Atlantis. The Atlanteans could not stop them from entering their bodies. Finally, almost every person in the world was totally possessed by these beings from another dimension. These spirits were really Earthlings like us, but very different, not coming from this dimensional level. It was a total catastrophe-the biggest catastrophe the Earth has probably ever seen.

Disruptive Heritage: The Bermuda Triangle The Martians' attempt to control the world took place near one of the Atlantean islands in the area we now call the Bermuda Triangle. There's an actual building sitting on the ocean floor down there that contains three rotating star-tetrahedral ElectroMagnetic fields superimposed on each other, creating a huge synthetic Mer-Ka-Ba that stretches out over the ocean and into deep space. This Mer-Ka-Ba is completely out of control. It's called the Bermuda Triangle because the apex of one of the tetrahedrons the stationary one-is sticking up out of the water there. The other two fields are counter rotating-and the faster-rotating field sometimes moves clockwise, which is a very dangerous situation.

(When we say clockwise, we mean the source of the field, not the field itself. The field itself would appear to be rotating counterclockwise.)

You'll understand this when you learn more about the Mer-Ka-Ba. When the faster field rotates counterclockwise (from its source), everything's okay; but when the faster Note: For those of you who believe that we will be out of this dimension before 2012, you are probably right. The correction to this Atlantean field, even though the Earth will probably be in at least the fourth dimension by then, will be completed in that third-dimensional year, according to Thoth.

A primary cause of much of the distortion in the world-the distortion between humans such as wars, marital problems, emotional disturbances etc.-is an imbalanced magnetic field. That field is not only causing distortions on Earth, it's causing distortions way, way, way out in remote areas of space because of the way Reality is constructed. That's one of the reasons why this race of beings called the Grays, and

other ET beings we'll talk about at the appropriate time, are trying to correct what happened here long ago. This is a big problem that extends way beyond Earth. What they did back in Atlantis was against all galactic law. It was illegal, but they did it anyway.

It will be solved, but not until the year Z012. There's not much the ETs can do in the meantime, but they'll probably keep trying. Eventually they'll succeed.

The Solution: A Christ Consciousness Grid Ascended Masters Assist the Earth

At the time of the synthetic Mer-Ka-Ba failure, there were about 1600 ascended masters on Earth, and they did everything they could to try to heal the situation. They tried to seal the dimensional levels and get as many of these spirits as they could out of people and back into their own worlds. They did everything on every level they could. They eventually got most of the spirits out and healed about 90 to 95 percent or more, people still found many of these unusual beings living; in their bodies.

The situation at that time began to deteriorate extremely rapidly. All the systems on Atlantis-financial, social and all the concepts of how life ought to be-degenerated and collapsed. The continent of Atlantis and all its people became sick. They started getting weird diseases. The entire continent went into a state of survival just trying to live through each day.

The situation grew continually worse. For a long period of time it was hell on Earth, horrible. If it had not been slowed down by the ascended masters, it would truly have been the end of this world.

The ascended masters (the highest levels of our consciousness at that time) didn't know what to do to help bring us back into a state of grace. I mean they really didn't know what to do. They were children compared to the events that had been forced upon them, and they had no idea how to handle it. So they prayed. They called in higher levels of consciousness.

They called in everybody who could hear their plea, including the great Galactic Command. They prayed and prayed. So the problem was reviewed on many high levels of life.

Similar kinds of events have happened before on other planets; this wasn't the first time. So before it actually happened, our ascended masters and galactic friends knew that we were going to fall out of grace, out of the high level of awareness we were experiencing at the time. They knew that we were going to fall way down the spectrum of life. Their concern was to figure out some way to get us back up on track after the fall, and they knew it had to be done quickly. They were looking for a solution that would heal the whole Earth, both the dark and the light. They weren't concerned with a solution where only the Martians would be healed, or only the Lemurians or only part of the Earth. They were looking for a situation that would heal the whole Earth and all of its inhabitants.

Higher levels of consciousness don't go along with this "us and them" point of view. There's only one consciousness moving through all life, and they were trying to get everybody to come back into a state of love and respect for each other. They knew that the only way they could do it was to get us back into Christ consciousness, a level of beingness where we can see the unity, and they knew we would proceed from there with love and compassion. They knew that if we were going to get back on track, we would

have to be in Christ consciousness as a planet by the end of the 13,000-year cycle-which is now. If we were not in Christ consciousness by then, we

wouldn't make it at all. We would destroy ourselves. Although spirit is eternal, life interruptions can be temporarily lost.

The only problem was that we couldn't get back to Christ consciousness by ourselves, at least in a short time. Once we had fallen to this level it would be a very, very long time before we would be able to come back up naturally. So the problem was really one of time. We were part of a greater consciousness that loved us, and out of love it wished to assist us back into conscious immortality as soon as possible. It would be much like having a child who hit his head real hard, resulting in a concussion. You would want him to return to consciousness quickly.

It was finally decided to try a kind of standard operating procedure that usually works in these situations, though not always. In other words, it was an experiment. Earth's people were about to be subjects of a galactic experimental project in the hope of helping us. We would experiment on ourselves.

It wasn't done by extraterrestrials or anything like that; they simply showed us how to do it. We were given instructions on how to proceed with this experiment, and we actually carried it out successfully. What about the Sirians? Our helpers honestly believed that we would make it, though they knew it would be close. In fact, they wouldn't have gotten permission from the Galactic Command to do the experiment if they hadn't honestly believed we would make it. You can't lie to the Galactic Command.

A Planetary Grid

At this point, so that you'll understand the procedure they decided on, I need to talk about grids. A planetary grid is an etheric crystalline structure that envelops the planet and holds the consciousness of any one species of life. Yes, it does have an ElectroMagnetic component associated with the third dimension, but it also has an appropriate higher-dimensional component for each dimension. Science will eventually discover that there's a grid for every single species in the world. There were originally 30 million grids around the Earth, but now there are about 13 to 15 million, and they're decreasing rapidly. If there are just two bugs on the planet, and they're just sitting somewhere in Iowa, they have a grid that stretches around the entire planet, or they couldn't exist. It's just the nature of the game. Each of these grids has its own geometry and is unique; there's not another one like it. Just as a species' body is unique, its point of view of interpreting the Reality is also unique. The Christ consciousness grid holds the Christ consciousness for the planet, and if that grid isn't there, we can't reach Christ consciousness. This grid was there during Atlantean times, though we were very young, and it was beginning to function at certain times during the precession of the equinoxes. They knew it would be placed into a passive state by the Martians' actions, so they decided to synthetically activate the Christ consciousness grid around the Earth. It would be a living grid, but it would be synthetically made-like creating a synthetic crystal from a living cell of a live crystal. Then at the right time, hopefully before we killed ourselves off, the new grid would be complete, and we could ascend to our previous level once again. One example of the effect of a grid is shown in the Hundredth Monkey Theory.



Walk
a Mile
in My
Shoes
before you judge me
You try walking a mile
in these shoes

The Hundredth-Monkey Concept

You have probably read the book, *The Hundredth Monkey* by Ken Keyes, Jr., or perhaps the earlier book of Lyall Watson, *Lifetide: The Biology of the Unconscious*, who describe a 30-year scientific research project on the Japanese monkey, *Macaca fuscata*. The island of Koshima, Japan, has a wild colony and the scientists were providing them with sweet potatoes dropped in the sand. The monkeys liked the sweet potatoes, but not the sand and dirt. An eighteen-month-old female they named Imo found she could solve the problem by washing the potatoes. She taught this trick to her mother. Her playmates also learned this new way, and they taught their mothers, too. Soon all the young monkeys washed their sweet potatoes, but only the adults who imitated their children learned this behavior. The scientists recorded these events between the years 1952 and 1958.

Then suddenly, in the autumn of 1958, the few monkeys doing this on the island of Cosimo reached a critical mass, which Dr. Watson arbitrarily placed at 100, and bingo!—almost every monkey on the island started washing its potatoes without any further influence. If it had happened on only that one island, they probably would have figured there was some form of communication and looked for it. But simultaneously the monkeys on the surrounding islands also started washing their potatoes. Even on the mainland of Japan in Takasakiyama the monkeys were washing their potatoes. There was no possible way these monkeys could have communicated by any way we know. It was the first time that scientists had ever observed anything like this. They postulated that there must have been some kind of morphogenetic structure or field that stretched across these islands through which the monkeys were able to communicate.

The Hundredth Human

Many people thought a lot about the Hundredth Monkey phenomenon. Then a few years later a scientific team from Australia and Britain wondered if human beings possessed a grid similar to the monkeys. They did an experiment. They made a photograph that had hundreds of human faces in it, little ones and big ones, faces in the eyes. Everything was made up of these faces, but when you first looked at it, you could see only about six or seven. It took training to see the other ones. Usually someone had to first point out where they were.

These people took their picture to Australia and conducted a study there. They selected a certain number of people from a spectrum of the population, then showed each of them the picture, giving them a certain length of time to look at it. They held the photograph up to someone and said, "How many faces do you see in this photo?" During the time the subjects were given, they would generally come up with six, seven, eight, nine or maybe ten faces. Few people saw more. When they had gotten a few hundred people as their basic sampling and recorded accurately what had been observed, some of the researchers went to England—on the other side of the planet—and showed the picture on a closed-cable BBC television station that broadcasts only to England. They carefully showed where all the faces were, every single face. Then a few minutes later other researchers repeated the original experiment with new subjects in Australia. Suddenly people could easily see most of the faces.

From that moment, they knew for certain that there was something about humans that had not been

known. Now, the Aborigines in Australia had known about this "unknown" part of us for a long time. They knew that there was an energy field connecting people. Even in our society, we've observed that somebody on one side of the planet would invent something very complex at the same moment that someone on the other side of the Earth invented the same thing, with the same principles and ideas. Each inventor would say, "You stole it from me. It was mine. I did it first." This has happened many, many times, stretching back for a long time. So after this Australian experiment, they began to realize that something very definitely connects us all.

The Government's Discovery of the Grid and the Race for Control As far back as the early 1960s, the American and Russian governments had discovered these electromagnetic fields, or grids, that stretched around Note: In the movie *Stargate*, Ra was not given proper respect. He was actually one of the ascended masters and a being of light, not evil. the world. Human grids-yes, there are more than one-are high above the Earth, about 60 miles or more. There are the five levels of consciousness on Earth that correspond to different numbers of genes and different heights? Well, there are only three levels of consciousness that Earth is actually experiencing right now. Two others are way beyond us at this time. The first level is primal, the second level is our present consciousness, and the third level is the Christ or unity consciousness, the one we're about to enter. After the Fall, about 13,000 years ago, there were only two active human grids around the Earth, the first and the second levels.

The Aborigines in Australia were on the first level, for example, and we, the mutants, were on the second level. (That's what they call us-mutants-because we mutated to where we are now.) Science has done very little research on the Australian Aborigines, so our countries haven't become aware of their grid. But the governments did a lot of research on us, and they discovered exactly what our grid looks like: It's based on triangles and squares. It's a very male grid that stretches around the whole planet. Now, we have a third grid up there, which we will call the unity-consciousness grid, or simply "the next step."

It's been there, completed, since February 4, 1989. Without that grid, it would be all over for us, folks. But it is there. The governments became originally aware of our second-level grid maybe as far back as the 1940s. I realize that this statement is in contradiction to what was said above. But nevertheless I believe that the grid was discovered even before the Hundredth Monkey theory came out. Because of World War II, the governments were beginning to place military bases all over the world in little out-of-the-way places, on obscure islands like Guam. Why did they select these particular places for their bases? It probably wasn't for the reasons they said.

When you lay out the grid and the military bases all over the world, especially those of Russia and the United States, well, son-of-a-gun, the bases are almost always located right on the nodal points of the grid-exactly over the top or on little spirals that come off of the nodal points. It could not possibly have been a coincidence that they just happened to spread out their empire of military bases in these precise places. They were trying to take control of this grid, because if they could control it, they knew they could control what we think and feel. A subtle war was going on between these two governments. However, the war changed its nature considerably in 1970, though I'll have to explain that later. Of course, behind both the United States and Russia was the secret government, which controlled the outer appearance and timing of this conflict.

How the Grid Was Constructed, and Where

Now that we have the necessary background, we can continue with the drama in Atlantis. The project to rebuild the grid was begun by three men: Thoth, a being named Ra and a being named Ararat. These men flew to a place in what is now Egypt, to the area now called the Giza plateau. At that time it was not a desert, but a tropical rain forest, and it was called the

Land of Khem, which means the land of the hairy barbarians. The three men went to that particular place because the axis of the old unity-consciousness grid extended out of the Earth from that point. They were going to rebuild a new grid on the old axis, according to instructions given by higher consciousness.

They had to wait until the right moment-until the precession of the equinoxes passed the low ebb in consciousness-before they could act, and this low ebb was still far into their future. After that they would have a little less than half a cycle, about 12,900 years or so, to complete everything by the end of the twentieth century. We couldn't go any longer than this or we would destroy ourselves and our planet.

First they had to complete the grid on the higher dimensions, then they had to physically build the temples in this dimension before the new unity grid would manifest. Once manifested and balanced, they were to help us begin to consciously move into the higher worlds of being and begin anew our path home to God.

So Thoth and friends went to the very spot where the unity-consciousness vortex exited the Earth. This point was about a mile away from where the Great Pyramid sits in the desert today, but then it was out in the middle of nowhere, in the middle of a rain forest. Centered right over the axis of this vortex on the Earth, they created a hole extending approximately one mile into the Earth, lining it with bricks. It took only a few minutes or so, because they were sixth-dimensional beings, and whatever they thought always happened. It was that simple.

Once the hole aligned with the unity axis was created, they mapped the ten Golden Mean spirals that emerged from the hole and located where they moved above the Earth. They used the hole as the axis, starting far down, and mapped the spirals of energy as they moved up out of the hole and extended into space. One of the spirals exited the Earth not far from the present Great Pyramid. Once they found it, they built a little stone building in front of the hole; that building is the key to the entire Giza complex. Then they built the Great Pyramid. According to Thoth, the Great Pyramid was built by himself, not Cheops. Thoth says that it was completed about 200 years prior to the shifting of the axis. The apex of the Great Pyramid, if the capstone were in place, sat exactly on the curve of the spiral. They lined up the center of the hole with the south face of the stone building and the north face of the Great Pyramid. It has amazed surveyors who have looked at this. Though these structures are a mile away from each other, the south face of the stone building and the north face of the Great Pyramid are in perfect alignment. They do not believe that we could do it any better today even with our modern technology.

Later the other two pyramids were also built directly on that spiral. In fact, that's how the hole was discovered, through aerial photography. They noticed that the three pyramids were laid out on a logarithmic spiral. Then they traced the spiral back to its source and went to that spot, and there was the hole and the stone building. That discovery was made, I believe, in the early 1980s. It was recorded in the McCullen survey that was completed in 1985.

I've seen the axis hole and the building with my own eyes. I consider it to be the most important place in all of Egypt and so does the Edgar Cayce A.R.E. There's also another hole about a city block away from the first spiral, and this spiral starts out a little differently, but then slowly, asymptotically, superimposes itself over the first spiral. To be able to build around this hole in this spiral pattern, the planners had to have a very sophisticated understanding of life. (I'll explain this understanding later also.) So, these two completed spirals defined the axis of what would eventually become the unity-consciousness grid around the Earth.

Sacred Sites

After starting the new grid over the existing collapsed grid and putting one pyramid on the line of the spiral, Thoth, Ra and Ararat mapped where these two energy lines curved and crossed each other in over 83,000 places on the surface of the Earth. Fourth-dimensionally, one dimension higher than this one, they constructed an entire network of buildings and structures over the whole planet, placing them on the nodes of this energy matrix. All of these structures were laid out with the proportions of either the Golden Mean or Fibonacci spirals, and all were mathematically referred back to that single point in Egypt now called the Solar Cross.

The location of the sacred sites of the world are no accident. It was a single consciousness that created every single one of them—from Machu Picchu to Stonehenge to Zaghouan—you name it, to anywhere. Almost all of them (with a few exceptions) were created by a single awareness.

We're becoming more aware of this now. Richard Hoagland's work brings this forth, though he wasn't the first one. They show how one sacred site is extrapolated from another one, then another and still another. These sites go beyond time, in that they were all built at different times, and they go beyond any particular culture or geographical location. They were obviously done by one consciousness who coordinated the whole enterprise. Eventually researchers will see that this spot in Egypt is the point from which all the other sacred sites were calculated.

This Egyptian area is the north pole of the unity-consciousness grid. On the other side of the planet, out in the South Pacific in the Tahitian Islands, is a little island called Moorea, where the south pole of the grid is located. For those of you who have been on top of Wayna Picchu for a birds-eye view, Machu Picchu, at about 9000 feet in the Peruvian mountains, seems to be surrounded in a perfect circle by mountains. It's like a female circle surrounding a phallus rising in the middle. Well, the island of Moorea is similar to this, only it's shaped like a heart. Each house on Moorea has a heart with the house number on it.

The phallic Moorean mountain in the center of the heart is much bigger than Wayna Picchu in Peru, but you will still see the same ring of mountains surrounding this earthen pole. This is the precise south pole of the entire unity-consciousness grid. If you go straight through the Earth at Moorea, you come out in Egypt. It's off only an ever so tiny bit—there's a very slight curve, which is natural. The Moorean pole is negative, or female, and the Egyptian pole is positive, or male. All the sacred sites are connected to the Egyptian pole, and they're all interlinked through the central axis leading to Moorea. It's a torus, of course.

The Appearance of the Heroine

Every single time we reach that vulnerable point in the precession of the equinoxes when our poles make these little shifts, extraterrestrials have tried to take over the planet, according to The Emerald Tablets. This has been going on for millions and millions of years, and it's still going; cm.

When I read that in the Tablets, I didn't yet know about the Grays or any of these beings, and I thought, "Someone coming from somewhere else to take over the Earth? Naw, this is silly!" But even today, this same thing's going on. It never stops, it just keeps on. It's called, simply, the battle of the dark and the light.

Every single time a takeover seems imminent, there has always been one very pure person who figures out how to get into the next level of consciousness, then finds the ship and raises it into the air. The Earth and the Sun connect within that person and give him or her great power, then whatever that person thinks and feels will happen. That's how this airship is a warship: Whatever races are trying to take over Earth, this person just thinks them away—thinks up a situation that forces them to leave. This keeps our evolutionary process going without any kind of outside interference or influence. At least that's what is supposed to happen.

By now we have definitely been tampered with. That pure person has appeared, and that event has already happened here on Earth. This is why the Grays are leaving. The problems they're having is because of one single woman—one 23-year-old female from Peru (she was 23 in 1989 when she did this). She made the first ascension process up to the new grid and connected with it, connected with the Earth, found the ship and raised it into the air. First she made some basic connections that had to be done with crystals on the Earth, then performed the programming that had to be recalculated. The very next thing she did was to think that the Grays and others related to this attempted takeover of Earth were going to become sick if they remained here, and there would be no cure. Within one month, all the Grays started getting sick, and the whole process she envisioned began to happen. The Grays have been forced to leave the Earth now. Their bases have been abandoned, and they have been forced to alter their plans. The presence of this entire army of beings from space has now been reduced to almost nothing, all because of one small but holy woman.

Awaiting the Atlantean Catastrophe

Thoth and his partners finished the complex in Egypt to help rebuild the grid. Then they abandoned it in the middle of the rain forest and went back to Atlantis to prepare. It sat alone for 200 years, because they knew that at that critical point in the precession of the equinoxes, the poles would shift.

They knew that Atlantis would sink, so they waited. One day it finally happened. The catastrophe actually took only one night. Science has proven that when poles shift, it takes about 20 hours. . You wake up one normal day, and that evening it's a totally different world. The whole process is about three and a half days long, but the pole shift happens in about 20 hours. We're all going to experience this enormous change when we see big chunks of the United States start to drop off into the water—then you'll know it's for sure. There are other early signs that will tip you off that the change is about to happen. When enough information has been given, I'll remind you of what you already hold in your

memories. When they saw the very first signs of the shift coming on, Thoth, Ra and Araragat returned to the Sphinx and raised the warship into the sky. All they did was raise the vibration of the molecules only one overtone higher than the Earth exists on. This allowed them and the ship to pass right through the Earth into the sky. Then they moved to Atlantis, lowered the ship to the surface, and picked up the people of the Naacal Mystery School, which included the original immortals from Lemuria as well as those who became enlightened during the time of Atlantis (by that time about another 600 people had ascended). So the original thousand from Lemuria and the 600 from Atlantis had increased the number of ascended masters to about 1600, the only occupants of the ancient airship.

Now, the people on this ship were not only passengers, they were creating a living group Mer-Ka-Ba that surrounded the ship with a very large field in the shape of a flying saucer-the same shape that's around the galaxy and around your body when your Mer-Ka-Ba is spinning. They had a very powerful protective field around themselves as they headed for Khem, soon to be the new Egypt. Thoth said that they had risen about a quarter mile off the planet with the members of the mystery school on board when they watched the island of Udal sink. This was the last piece of Atlantis to disappear into the water, with the exception of a few small islands. Then they flew the ship to Egypt and landed it on top of the Great Pyramid.

If you were to extend the Great Pyramid up to where the capstone would naturally terminate, you would find that the ship and the pyramid were built for each other. If you were to look at this from the top, it would look like the right-hand view in the figure. The circle is the ship and the square is the Great Pyramid. The perimeter of the Great Pyramid and the circumference of the ship are the same. It's debatable if that's possible or not, but they can get very, very close.

Whenever that mathematical relationship happens, life appears. It's the basic relationship of life throughout the universe. (We'll describe this geometrically soon.) If the ascended masters had not had spinning Mer-Ka-Ba fields around them, they wouldn't be here today (and probably neither would we), because their Mer-Ka-Bas protected them from all that happened next.

After they landed on the pyramid, the poles began to shift and the human consciousness of the Earth began to plummet. Simultaneously, the ElectroMagnetic and magnetic fields of the Earth collapsed, and all life on this planet went into the Great Void, the three and a half days of absolute blackness described by many cultures around the world.

The Three and a Half Days of the Void

The Emerald Tablets say that every single time we go around the precession of the equinoxes and our poles go through these changes, we go through a void space for about three and a half days. The Mayas described the Void in the Troano document. At one point in the story, three and a half stones are painted black. This refers to the time when we go into what we now call the electromagnetic null zone. As the poles shift, a phenomenon takes place (we'll go into great detail about this later) where for about three and a half days we're in darkness (it could actually be anywhere from two or two and a half days to a little over four days). The last time, it was evidently three and a half days. It's more than just blackness; it's nothing, it's void.

CE MICES for autism

micro.current.cranial.electro.stimulation

If you need more information on the SCIO and purchase details please get in touch with us

Maitreya Kft.

tel: +3613036043 | web: www.qxsubspace.com | e-mail: info@qxsubspace.com



It is scientific fact that when a low level voltage and micro-current pulse is applied to the body osmosis, enzyme activity, and healing are increased. The SCIO will let the patient's body electric autofocus a harmonic pulse to maximize this effect. This current applied to the cranium has been shown to help autism, attention deficit and hyperactive children. It has been shown helpful for anxiety, addictions, emotional disturbances, and insomnia.

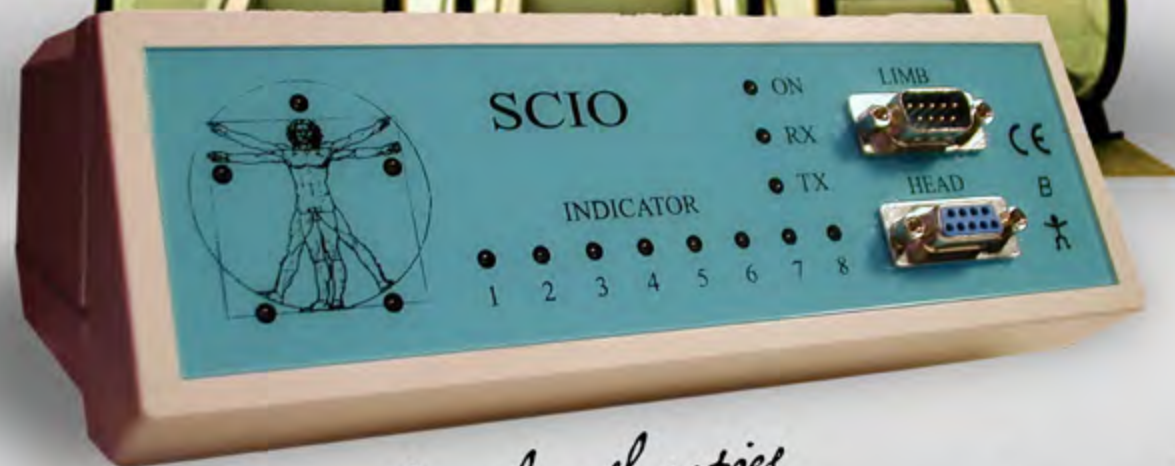

*There is published research on these therapies
The new world of energetic medicine can help you*

And, by the way, when you are in the Void, you will realize that you and God are one, that there is no difference at all. We'll talk about the Void again at the right moment.

Memory, Magnetic Fields and Mer-Ka-Bas

If the people on the warship hadn't been protected by the Mer-Ka-Ba during that change, they would have completely lost their memories. You see, our memory is held together primarily by a magnetic field that exists around the brain-inside the skull and around the head. That field is further connected to every cell in the brain by individualized magnetic fields within each cell. Science first found the internal magnetic particles within each cell and then found the larger outer field. This was the first new find in human physiology in the last 300 years. Memory is dependent on a steady, living magnetic field, very much like a computer. Its connection to the Earth's magnetic field is not understood by science at this time. If you don't have a means of protecting your memory, it will be erased, gone. It'll be like unplugging a computer in the middle of a file. It's just gone. That's exactly what happened to the Atlanteans and others who survived the catastrophe but who didn't have spinning Mer-Ka-Bas. Those very sophisticated people, who were more advanced than you and I, suddenly found themselves in a situation where they didn't know anything. They had hightech bodies and high-tech minds, but it was like having a great PC sitting on the table with no software, nothing there.

So the population that survived, and there were a few, had to start all over again. They had to begin at square one to figure out how to stay warm, how to make fire and so on. This loss of memory was the result of their forgetting how to breathe, forgetting their Mer-Ka-Bas, forgetting everything- falling down through the dimensions, going into a totally unprotected state and ending up in this very dense world-having to eat food again, doing all kinds of things that hadn't been part of our experience for a very long time. They were slammed into a very dense aspect of the planet and had to learn to survive all over again. This was all a result of the synthetic Mer-Ka-Ba experiment that had taken place on Atlantis. Without that small group of ascended masters, we would not have survived at all-we definitely would all have left human experience. The whole Earth experiment would have been over forever. But they kept the field alive, just barely, while everything else crashed around them. Besides the ascended masters, there were also two other groups on Earth who had Mer-Ka-Ba fields intact at the time. The Nefilim and the Sirians, our mother and father, kept their fields alive. I don't know where the Nefilim retreated to within this planet's dimensional worlds, but the Sirians remained in the Halls of Amenti, inside the inner earth. Both of these groups are still here on the planet, hidden within the dimensional worlds.

Stair-Step Evolution

According to Melchizedek knowledge, both the Sumerians and the Egyptians emerged onto the surface of the Earth at almost the same moment, complete, whole and perfect, with their language totally intact, with all their skills and understanding and knowledge, with almost no evolution prior to that time (at least none that science knows of). They simply appeared at one moment in history in their most perfect state. The writing that came out at that moment was extremely sophisticated and clear, and has never been improved on since. After that initial impulse, these cultures became less and less clear,

until finally these advanced civilizations degenerated away. You would think they would get better and more sophisticated as time advanced, but that's not what happened. This is scientific fact. No one in conventional archaeology knows how this happened or can even explain how it could have happened. It's a great mystery. Egypt and Sumer are placed into a special category called stair-step evolution by archaeologists. They were given this classification because of how they seemed to gain information and knowledge. What happened was, one day Egypt got its language, full and complete, then that knowledge leveled off; then a little while later they would know everything you could possibly imagine about, perhaps, building a certain kind of moat or water system. A little more time would go by, and then they would suddenly know everything about hydraulics. It would keep going on and on like that. How did the Egyptians and the Sumerians get this information? How did they suddenly, in one day, know everything? Interesting.

The Tat Brotherhood

Thoth's son Tat remained in Egypt with Ra after the Fall. Later this group became known as the Tat Brotherhood. Even today there's an external brotherhood in Egypt called the Tat Brotherhood, physical people who are the protectors and keepers of the sacred temples. Hidden behind the current Tat Brotherhood are the ascended masters.

So the immortal aspect of the Tat Brotherhood sat there waiting and waiting, observing and waiting, until the time when the Egyptians could receive their teachings. When that day finally came, which was the birth of Sumer and Egypt, the Tat Brotherhood watched until they found either a person or a group of Egyptians who were ready for the ancient knowledge.

Then one, two or three members of the Brotherhood appeared in bodies looking just like the people they were about to teach. They would go up to the surface, approach the person or group and give them the information outright. They flat-out said, "Hey, look at this. Did you know that if you did this and this and this, that this is what will happen?" The Egyptians would say, "Wow, look at that!" They would use the knowledge, thus creating a new "step" in their evolution.

Then the men and women from the Brotherhood would go back under the pyramid, the Egyptians who were given these teachings would give it to the rest of the culture, and the culture would quickly ascend to the next step. The Egyptians would assimilate that for a while; then the Brotherhood would look for another group that was ready for the next subject.

They'd go to the surface again and say, "Look, here's everything you want to know about this." They simply gave it to them. The ascended masters gave the people this information over a short period of time and their evolution simply shot up and up in stair steps.

The Parallel Evolution in Sumer

This same evolutionary pattern was also occurring in Sumer. Though the present historical line says that Egypt began in approximately 3300 B.C. and Sumer began 500 years earlier, in about 3800 B.C., I believe they both started at almost the same moment. I think that if historians would get their dates accurate, they'd discover that both Sumer and Egypt started only a few years apart. However, the

evolution in Sumer was led by the Nefilim, the mother aspect, and the one in Egypt was led by the Sirians, the father aspect. That's the primary difference. I think the mother and the father agreed, "Now is the time for our children to remember." I believe it was a parental decision, and that when researchers look very carefully, they'll find that both countries started to blossom at the same moment in time, which was tied to the point in the precessional orbit (point D) when it was most likely to be successful.

This is also how the Sumerians knew about the precession of the equinoxes. It takes 2160 years to recognize that there is a precession of the equinoxes, but the reason the Sumerians knew about it was because the Nefilim said, "Do you know there's a precession of the equinoxes?" Very simple. It's not a complicated thing. They just explained it all and the people wrote it down. The Sumerians knew about events that went back 450,000 years because they were given the information. They simply wrote it down and applied it. But after these ancient cultures got all this brilliant information, they degenerated. Why would they degenerate instead of going higher? Because they were in the sleep cycle, the "falling asleep" portion of the precession. They were falling more and more asleep with each breath, right into the Kali Yuga, the most asleep moment of the cycle. In the middle of the Kali Yuga-2000 years ago-was the time of Jesus, and humans were sound asleep and snoring. People in the Kali Yuga who read books and other studies written in the earlier, more-awake period had a difficult time fully understanding what was being written about. Why? Because they were relatively unconscious. This is why cultures all over the world, not just in Egypt and Sumer, degenerated until they ceased. Right now we are about to awaken fully and know the truth of our beingness. Some scientists were very excited as he told me that this team of 30 linguistics experts who got to see the inside now believe that the key to all languages in the world is in that pyramid. I believe he's probably correct. He understood sacred geometry, and as you will soon discover, sacred geometry is the root of all language in the universe.

There's a big difference between dying and resurrection, but there's an even greater difference in ascension-which is now possible, since the grid was completed in 1989. Ascension was highly unlikely until this grid was complete. In ascension you don't die at all; there's no death process involved as we know it. Of course, it is true that you no longer are on Earth, and from that point of view, you die. What happens is, you simply become aware of your Mer-Ka-Ba one way or another-either remembering it on your own, being taught it or however it happens to you. This means you become aware of your body as light. Then you're able to pass through the Void totally consciously-from the Earth side through the Void to the higher dimensions, aware the whole time. In this way you simply walk out of this life without going through the death process, which involves reconstructing your human body. When a person ascends, he/she simply disappears from this dimension and reappears in the next, passing through the Void.

Ascension is now completely possible, and this book is one possible set of instructions on exactly how to accomplish this process. You personally might not pass through ascension; you might actually die or go through resurrection. It doesn't make much difference at this point in the game of life on planet Earth, because if you die in the normal manner, you'll go into the third overtone and into a holding pattern for a while. Then when the rest of the Earth cycles through this coming change, all people on that third overtone will also rise to the same dimensional level as those who resurrected or ascended. Even the Bible refers to this, saying that at this time the dead will rise. There is no such thing as death; there are just different states of being. It's a little like water, which can be a liquid, solid (ice) or gas (fog), but it is still water.

Right now very few human reincarnations are occurring on Earth except under certain conditions. This is probably your last life, folks-this is it! Of course, there are exceptions to almost all rules, so there may be a few on this Earth who have decided to reincarnate. Time is running out. If we make it to the end of this century, I'll be amazed. I seriously doubt if the third dimension will still be available for human life by that time. Only God knows for certain. Where are the people coming from who are being born on Earth today? Not from here! I'll explain when I talk about the new children.

When the Sun Rose in the West

As Egypt began to evolve, it developed into two countries, Upper Egypt and Lower Egypt. Upper Egypt was south and Lower Egypt was north. Egyptians named Upper and Lower Egypt in this sort of reverse way of thinking because in their earlier life as a country during Atlantis, the Earth

was rotating in the opposite direction and the magnetic poles were reversed. Our present north was then south and vice versa. Not only did the poles shift their position after Atlantis, but the Earth actually rotated in the opposite direction. Thoth said that he's gone through five pole shifts: He's seen the Sun rise in the east and he's seen it rise in the west, then in the east, the west and again the east-five times! On the ceiling of the temple at Dendera, which is the heart chakras of the male aspect of the Christ grid, is an astrological zodiac that demonstrates this reversed polarity. The zodiac rotates in the opposite direction, as if the Sun rose in the west instead of the east. The River Nile flows from south to north, whereas almost all the other rivers in the world flow from north to south. This indicates to me that the Egyptians held onto the older energy flow even in the Earth. We are the creators of our universe. People involved in Sufism may remember Sufi Sam, also known as Murshid Sam Lewis. He was buried in the early '70s, I believe-at the Lama Foundation in New Mexico. There's a plaque over his grave that reads: "On that day the sun will rise in the west, and all men seeing will believe." He was referring to the time that's coming. When the poles shift this next time, there will be a reversal of the Earth's rotation, thus the way we move in relation to the Sun.



NEO MORPHEUS

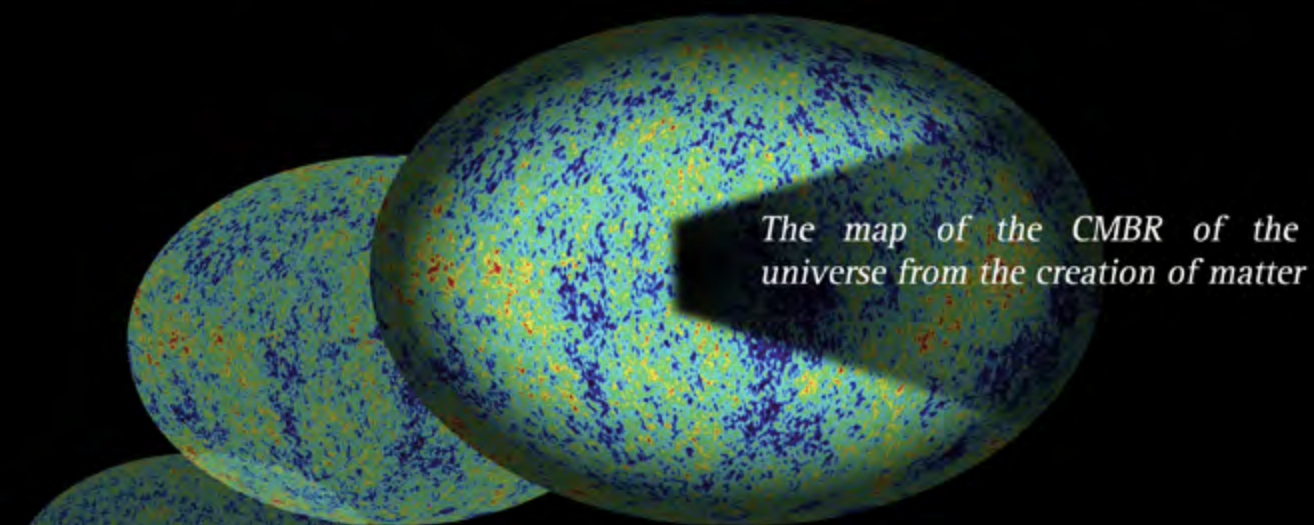

The map of the CMBR of the universe from the creation of matter

of prof. Nelson
for

IMUNE

A review of the science of the universe and its development of a true biology and truly modern medicine with Quantum Electrodynamics

The Transpersonal Holographic Memory of the First Level of Consciousness

Atlanteans, because of the way their brains functioned, had complete memory. They remembered everything that had ever happened to them. And their memory was transpersonal, which means that anything one person remembered, the others in their race could remember. The Aborigines in Australia have this type of memory right now. When anything happens to one Aborigine, any other can reexperience it anytime he or she wants.

If an Aborigine were to walk into this room right now, he or she would in effect be giving the experience to all of their race anywhere on the planet. You see, they're on the first level of consciousness where they're not separated from themselves. We're on the second level and are very separated from ourselves. Like the Atlanteans, Aborigines don't have memory like our vague kind of recollection; they have full-tilt 3D holographic memory. They could reconstruct this room moment by moment through the entire workshop, and all the rest of them could walk around in here and look at it.

They could walk up to your table and look into your eyes. It wouldn't be real time; it's what they call Dreamtime, like in a dream, but it's an absolute replica of the Reality. Their memory is perfect; they don't have any mistakes or flaws. Obviously, in that kind of culture the Atlanteans had no reason to write anything down. Why try to describe something with words when you've got the real thing?

They didn't need it; however, the Martian aspect did need it, so they had a written language. Even after the Fall, the Egyptians (and others) had an amazing ability to remember. At that point they had lost their holographic and transpersonal memory, but they still had photographic memory.

When the mystery school students were doing the complicated kind of training we'll be doing soon, they could do it all in their head. With our less efficient memory, we cannot do this in the same way they did; we have to struggle just to remember someone's name. The complexity will increase as we progress, making it difficult to remember from photo to photo, but the ancient ones could do this completely in their head. There is something about doing this in your head that's important, so later I'm going to show you some illustrations that will assist you to do this yourself.

This experience holds a primary key for understanding the nature of creation. Re-create the illustrations that follow as if you were actually in the Void moving through the geometrical movements. Experiencing it gives you the understanding that the circles on the page represent actual movements, and that these geometrical movements of spirit in the Void are the beginning and end of creation.

The Introduction of Writing, Which Created the Second Level of Consciousness

The Forty-Two Books of Thoth record that after the Fall, when the Atlanteans got into Egypt and were no longer experiencing full memory, writing was introduced. In fact, it's written right in the Egyptian records that it was Thoth who introduced writing to the world. This one act completed the "fall" and threw us out of the first level of consciousness and fully into the second, because it changed the way we accessed memory. It sealed our fate.

This act of learning how to write caused us to grow the top half of our skull from our eyebrows up. The simple act of introducing writing changed many factors in the way we perceive our Reality. To get at our memory now, we have to go in and pull out the desired information with a code. We go in with a word or a concept to bring back the memory of whatever it is.

In fact, we can't even remember something without having certain eye movements. Our eyes have to move in certain ways in order for the memories to flow out. The Egyptian memory system was vastly different from the way it was before the Fall. Comparing this change of memory to the Osiris saga, the Egyptians had entered the stage where they were in separate pieces, where they were inside their bodies, thinking they were separate from the rest of Reality. This feeling of being separate was, of course, destined to change many aspects of how human beings live.

Memory: The Key to Immortality

You might wonder, If Akhenaten and others were immortal, then why are they dead? I'll give you the definition of immortality from a Melchizedek point of view, which hopefully will help. Somebody else may have a different definition, but this is what we feel. Immortality has nothing to do with living in the same body forever. You're going to live forever anyway; you have always been alive and you always will be, but you might not be conscious during all that time. The definition from our point of view has to do with memory. When you become immortal, you reach the point where your memory remains intact from then on. In other words, you're conscious from then on, with no unconsciousness coming in. It means you stay in the body as long as you want to, and when you want to leave it, you leave. To have to stay in a single body forever would be a jail or a trap, because it means you couldn't leave. There might be a reason for leaving that body, and you will eventually find that you want to go beyond wherever you are. This is the definition of eternal life: Simply put, you have continuous, unbroken memory.

Back now to what happened after Akhenaten was dethroned. In order to let things get back to the old ways, which they wanted to do, the country went into a transitional state. The people who became king and queen directly after him are almost comical—they let Ay and Tiya take over the country. We have a long time lag here, then they became king and queen. It's written right in the records. They took over for around thirty years, and then they gave it to Seti I, who became the first king of the Nineteenth Dynasty. He immediately changed everything back to the old way, erased everything and called Akhenaten the same name they called Jesus—"the criminal." He called him the worst king who ever lived because of his teaching that there was only one God.

What Really Happened to Akhenaten?

Most of Egypt hated Akhenaten, except for a small group. The priesthood hated him most of all because Egyptian religious beliefs were centered on the priests. They controlled the people, their way of life and the economy. They became rich and were more powerful than anybody else. Then Akhenaten came along and said, "You don't need priests; God is within you. There is only one God, and you can access God from within your own self." The priests reacted to protect themselves and their vested interests. Also, Egypt had the most powerful military in the world, and when Akhenaten became pharaoh, they were chomping at the bit, ready to go out and take over the world. Akhenaten said no. He was a complete pacifist and said, "Come back onto our soil. Do not attack anyone unless you're attacked." He made the military come back and sit by idly, and they didn't like that.

So he had not only the priesthood, but the military against him. On top of that, the people themselves were into their little religions, and they loved worshiping their little gods. This wouldn't ultimately do them any good—it wouldn't get them where they needed to go according to the DNA plan of the universe—which was back home to God, to the one God—but nevertheless they were really into what they were doing.

When the people were forcefully told that they could no longer do certain religious acts, this caused great animosity toward Akhenaten. It would be like our president saying, "Okay, there are no more religions in the United States; there's just the president's religion." And if the president brought all the military back onto American soil with an isolationist point of view, he wouldn't be very popular. Neither was Akhenaten. But he knew that he had to do it no matter what, even if it meant his own death.

He had to do it to correct the pathway that our collective DNA had encoded into the Reality. In addition, he needed to put into the akashic records the memory of the sacred purpose that Christ consciousness held. So what happened then? According to the accepted history, the priesthood and the military got together and gave Akhenaten a poison that killed him.

The Essene Brotherhood and Jesus, Mary and Joseph

After Akhenaten was gone, the 300 immortal Egyptians joined the Tat Brotherhood and waited from roughly 1350 B.C. to about 500 B.C.—about 850 years or so. Then they migrated to a place called Masada, Israel, and formed the Essene Brotherhood. Even today Masada is known as a capital of the Essene Brotherhood. These 300 people became the inner circle, and mostly ordinary people formed an outer circle, which became very large. Mary, the mother of Jesus, was one of the members of the inner circle of the Essene Brotherhood. She was immortal even before Jesus became immortal. Joseph came from the outer circle. This is according to Thoth; it's not written in the records. It was part of the Egyptian plan that the next step would be to bring in someone who would demonstrate exactly how to become immortal when starting as an ordinary human, put the experience into the akashic records and make it real. Somebody had to do it. According to Thoth, Mary and Joseph came together and mated interdimensionally (which we'll talk about later) to create the body for Jesus, which would allow his consciousness to come in from a very, very high level.

When Jesus first came in, he began life on Earth as human as any of us. He was totally human. And

through his own work he transformed himself to the immortal state through resurrection, not through ascension, and put into the akashic records the process of exactly how to do it. This is according to Thoth, and it was planned a long, long time before it ever took place.

The Two Mystery Schools and the 48 Chromosomal Images

We're now changing direction again and beginning a new system of knowledge that will continue for a while until you see this symbol again a long way down the line. This was the symbol for the Egyptian Mystery School of Akhenaten, the Law of One. It's the Right Eye of Horus. The right eye is controlled by the left brain; it's male knowledge. Although the right eye "sees" directly to the right brain, this is not what the Egyptians were communicating. It is not the "seeing" but rather the interrupting of the "seeing" information that was important here. It is the left brain that makes this interruption of what is seen; it controls the right side of the body, and vice versa. In the same manner, the Left Eye of Hours, controlled by the right brain, is female knowledge, which was taught in the twelve primary Egyptian temples along the Nile. The thirteenth temple was the Great Pyramid itself. It took twelve years of initiation, spending; a year, one cycle, in each of these temples learning all the feminine components of consciousness.

But the male component, the Right Eye of Horus, was taught only once, and it was not written down anywhere. It was purely an oral tradition, though its primary components are etched on a single wall under the Great Pyramid that leads into the Hall of Records. As you go down that all, you get almost to the bottom, and just before it makes a 90-degree turn, high up on the wall you see an image about four feet in diameter, which is the Flower of Life. Beside it you would see other images, one after another, which are the images of the chromosomes of Christ consciousness, the level of consciousness we're moving into now.

These images will be given throughout this book, mixed up and in slightly different form. This is what the Great Pyramid is all about. Its primary purpose, beyond anything else, is to take someone from our level of consciousness into the next level. There are lots of other reasons why it's in existence, but ascension and resurrection are the absolute purpose.

Genesis, the Creation Story

We're going to begin with a realization that the Christian and the Egyptian understandings of Reality are almost identical. The Christian understanding is derived from the Egyptian. Here are the first three sentences of the Christian Bible: "In the beginning God created the heaven and the earth. And the earth was without form and void, and darkness was upon the face of the deep, and the spirit of God moved upon the face of the waters. And God said, 'Let there be light,' and there was light."

To begin with, this statement that the Earth was without form until it came out of the Void, out of nothing, is exactly what the Egyptians believed. It's also what many other religions believe. Both Egyptian and Christian religions believe that all that's needed to start the process of creation is nothing and spirit, and when those two concepts are brought together, then all things can be created. They

believe that creation begins by the movement of spirit. In the second sentence it says, "The earth was without form and void" and that the spirit of God moved upon the face of the waters. Then in the very next sentence, God says, "Let there be light." The movement happened first, then the light happened immediately after. According to the Egyptian belief, one tiny detail was left out of the current Christian Bibles. It isn't necessarily wrong in the older Bibles, though. There are 900 versions of the Bible in the world, and in many of the older ones the first sentence says, "In the beginning there were six." It starts out in other ways too; it's been changed many times over the years. The ancient Egyptians would say that the way our modern Bibles begin creation is impossible, especially if you think about it from a physics point of view. Imagine a dark, infinite space that goes on forever and ever in all directions. There's nothing in it—just infinite space with nothing in it.

Imagine yourself—not your body, but your consciousness—being in the middle of that. You're just floating there with nothing. You can't really fall, because where would you fall to? You wouldn't know if you're falling down or going up or off to the side; in fact, there's no way to experience any motion at all.

From a purely physics or mathematical point of view, motion itself, or kinetic energy, is absolutely impossible in a void. You can't even rotate, because motion cannot become real until there's at least one other object in the space around you. There has to be something to move relative to. If you don't have something relative to move to, how would you know you're moving? I mean, if you went up thirty feet, how would you know that? There's no change. With no change, there's no movement. So the ancient Egyptians would say that before God "moved upon the face of the waters," He/She had to first create something to move relative to.

How God and the Mystery Schools Did It

Now, think of yourself standing in a dark room, near the door to a second room. You are ready to go into the second room, which is very, very dark. You can barely see the door leading into it. You go into the second room, close the door behind you, and it's pitch black. When you're faced with that situation, you have the ability to project a sensing beam from your third-eye area, and you can also sense from your hands.

(You can actually sense from any chakras, but people usually do it from their third eye or their hands.)

You can project a beam of consciousness into that dark room for a certain distance. It might go only an inch, or maybe you can feel outward a foot or two, and you just know that nothing (or something) is in that space. Your consciousness goes out this distance and then it stops. Your knowingness quits, and you don't know what's beyond that. You probably all know what I'm talking about, though a lot of us have allowed that sense to retreat because we rely on our eyes so much. But some people, especially the ancient Egyptians, were really good at this. They could go into a dark room and feel all around and know if anything was there even though they couldn't see a thing with their eyes.

There are blind people who can also demonstrate this ability. We actually have six of these sensing rays—not just one, but six. They all come from the center of our heads, the pineal gland. One ray comes out the front of our head at the third eye and another goes out the back; one goes out of the left and another out of the right side of our brain; and another goes straight up through the crown chakras and the sixth

straight down through our neck-the six directions. These are the same directions of the x-y-z axes of geometry. The Egyptians believed that this innate aspect of consciousness is what allows creation to begin. They believed that if we didn't have this ability, creation would never have happened. In order to understand this process of creation on the deepest level, Egyptian students were told to imagine and enact the process we are about to go through. The following description is how they explained and practiced it in their mystery schools. The way they learned isn't the only way it could have been done, but this is how they were trained. The dark background in this picture represents the Great Void, and the little eye represents the spirit of God. So here's the spirit of God existing in the Void, out in nothing. Imagine that you're that little spirit in the middle of the Void. (When you're in the Great Void, by the way, you will realize that you and God are one, that there is no difference at all.) After hanging out in the Void for a long time, you probably would get bored or curious or lonely, and you would want to try something new, to have some new adventure in your life.

First Create a Space

So spirit, the single Eye, shoots a beam of consciousness out into the Void. It shoots this beam first to the front, then to the back, then to the left, then the right, then straight up and straight down. Realize that whatever distance you project out front, you project the same distance out back, also to the left, the right and up and down. The consciousness beam projects the same distance in all six directions for any one individual. Even though each one of us is different in how far we can project this beam (one of us might project an inch, another two feet and another fifty feet), there is equality in all six directions. So spirit projects those beams outward in those six directions, defining space: north, south, east, west, up and down. This might be why the American Indians and native people all around the world find the six directions so important. Have you ever noticed this in their ceremonies, how important it is that they define the directions? It's also important in the Kabbala, in some of the meditations they do.

Next, Enclose the Space In the mystery schools, after they've projected these six beams in the six directions, the next thing they do is connect the ends of these projections.

This forms a diamond, or square, around them. Of course, when it's at the angle shown in this diagram, it looks like a rectangle, but you can see that it would actually be a square. So they make a little square around their point of consciousness. Then from the square they send a beam up to the top, forming a pyramid around the base of the square. After they create the pyramid on top, they then send a beam down to the bottom point, forming a pyramid. If you look at this in actual 3D space, the two back-to-back pyramids form an octahedron. Here's another rendition of the octahedron .

Remember that this is just spirit. You don't have a body in the Great Void; you're just spirit. So you're in the Great Void, and you've created this field around you. Now, once you've defined the space by mapping out the octahedron with two back-to-back pyramids, you have an object. Kinetic energy or movement is now possible; something is now possible that was not possible before. Spirit can move outside the shape and move around it. It can go in any direction for miles and miles, then come back and have a center place for everything. The other thing spirit can do is remain stationary in the middle of the shape, letting the shape move instead. The shape can rotate or wobble or move in all possible ways. So relative movements are now possible.

Then Spin the Shape to Create a Sphere

The octahedron the students created this way had three axes-front to back, left to right, and up and down. They were told to spin the shape around one of the axes-it didn't matter which, and it didn't matter which direction. They would spin it one way or the other, then they would spin the shape once around another axis, and once around the third axis. With just one spin around each of the three axes, they traced the parameters of a perfect sphere. Before the students were allowed to move their own point of consciousness, they were taught to spin this octahedral form and create a sphere around themselves.

It has been agreed upon by everyone involved in sacred geometry that I know of, that a straight line is male and any curved line is female. Thus one of the most male forms is a square or a cube, and one of the most female forms is a circle or a sphere. Since the octahedron that spirit projected is made up of only straight lines, it's a male shape; and since the sphere is made of only curved lines, it's a female shape. What the Egyptians did was to create a male form and then convert it to a female form. They went from maleness to femaleness.

This same story is related through the Bible where Adam was created first, and then from Adam, or out of Adam's rib, was created the female. Of course, the image of spirit inside the sphere is also the image of the school. Sacred geometry started when spirit made its first projection into the

Void and created the first octahedron around itself. The Void is infinite- nothing in it-and these forms being created are also nothing.

They're just imaginary lines created out of consciousness. This gives you an indication of what Reality is-nothing. The Hindus call Reality *muyu*, which means illusion.

Spirit can sit in the middle of its first creation for a long time , but eventually it'll make a decision to do something. To re-create this process, mystery school students were given instructions to reenact the same motions that spirit took. Two simple instructions are all that's required to create and complete everything in the entire universe.

The First Motion in Genesis

Remember that spirit is now sitting in a sphere. The instructions are to move to that which is newly created, then project another sphere exactly like the first. That does something very special and unique. This is an absolutely foolproof system for creating Reality. You cannot make a mistake no matter what you do. All you do is move to what is newly created and project another sphere the same size as the first one. In this system, since nothing exists except this bubble in the Void, and the inside of the bubble is the same as the outside, the only thing that's new or different is the membrane itself, the surface of the sphere.

So consciousness decides to go to the surface. It makes no difference where it goes on the surface; it can go anywhere. It doesn't make any difference how it gets there either, whether it goes in a straight line or curves or spirals out or explores every speck of space in between. It can be really creative; it doesn't make any difference. But somehow or another it will end up somewhere on the surface of the sphere.

For purposes of this example we'll say spirit went up to the top (just to be symmetrical and easier to

deal with). Anyway, spirit, this little single eye, lands on the surface. It has just made the first motion in Genesis: "And the spirit of God moved upon the face of the waters." And the very next thing was: "God said, 'Let there be light,' and there was light." At this point spirit knows how to do only one thing-actually, it knows how to do two things, but the end result is one. It knows (1) how to project the little octahedron and create a sphere and (2) how to move to what's newly created. That's it, a very simple Reality. So once it arrives on the surface, it makes another octahedron, spins it through the three axes and forms another sphere identical in size to the first one. It's identical in size because its ability to project into the Void is the same. Nothing has changed in that respect. So it creates a second sphere exactly the same size as the first.

The Significance of Shape and Structure Developing the Genesis Pattern The Torus, the First Shape

Let's look at the first object that comes off the page-the Genesis pattern itself. If you look at a math book, this Genesis pattern has the minimal amount of lines that can be drawn on a flat surface to delineate the three-dimensional form called a torus. A torus is formed when you rotate the Genesis pattern around its central axis, creating a shape that looks like a doughnut, but the hole in the middle is infinitely small. A torus, here called a tube torus because this particular one is shaped like an inner tube, is unique in that it's able to fold in on itself, turning either inward or outward. No other shape in existence can do this or anything similar. A torus is the first shape that comes out of the completed Genesis pattern and is absolutely unique among all forms in existence.

It was Arthur Young who discovered that there are seven regions on this shape, which are collectively called the seven-color map. You can pick up almost any mathematics book, and if you go to the torus, it'll talk about the seven-color map. There are seven regions, all the same size, that will exactly fit in the tube torus with nothing left over. Just like on the Genesis pattern, six circles going around the seventh, central one take up the entire surface. It's perfect, flawless. In sacred geometry there's something called ratcheting. You take a circle or a line and ratchet it, like when you take a ratchet tool in car mechanics and use it to rotate something a certain distance.

For instance, imagine two Genesis patterns superimposed on each other. One pattern is fixed; if you rotate the other pattern 30 degrees, you would have twelve spheres around the central one. It would look like this in two dimensions. In three dimensions it would look like a tube torus. Then if you connect all possible lines in the middle, you get this pattern. Ratcheting the twelve spheres once more, this time 15 degrees, so that there are 24 spheres, you would get this pattern. This pattern has what is called a transcendental pattern associated with it. What is a transcendental pattern? A transcendental number in mathematics, from my way of looking at it, is a number that comes from another dimension. In that dimension it is probably whole, but when it gets here it does not completely translate into this world.

We have a lot of those. One of them, for example, is the phi ratio, which I'm going to talk about later. It's a mathematical proportion that starts out with 1.6180339 and continues forever, meaning you never know what the next digit is going to be, and it never ends: people have let computers run for months without coming to an end. As a simple explanation, that's what a transcendental number is.

The shape of the torus is what governs many aspects of our lives. For example, the human heart has seven muscles that form a torus, and it pumps in the seven regions shown in the map of the torus. We have

SCIO

CE measures treats

- Volts and Oscillations (EMG, EEG)
- Amps and Oscillations (ECG)
- Resistance (GSR)
- Hydration
- Oxidation (Redox potential)
- Ph acid vs alkalinity
- Reactivity evoked potential to voltammetric fields of substances (TVEP) over 228,000 measures a second of these energetic factors

- Brain wave and emotions with (MCES)
- Pain with (MENS) (TENS)
- Trauma or wounds (EWH)
- Electro Weakness Ph, Redox disorder (VARHOPE Correction)
- Trickle charge the body electric

If you need more information on the SCIO and purchase details please get in touch with us
Maitreya Kft.
 tel: +3613036043
 web: www.qxsubspace.com
 e-mail: info@qxsubspace.com



All designed to detect + reduce Electro-stress and Balanace the Body Electric Automatically

embodied all knowledge. The torus is literally around all life forms, all atoms, and all cosmic bodies such as, planets, stars, galaxies and so on. It is the primary Shape in

existence. "In the beginning was the Word." I believe that time will reveal that language/conscious sound/the word will all be revealed in the torus. There are those who believe this to be true now, but only time will tell.

The Labyrinth As a Movement of Life-Force Energy

The sevenfold labyrinth is used all over the world-everywhere from China to Tibet to England to Ireland to Peru to the American Indians. One was just found in Egypt. You'll find this labyrinth on the floors of many of the churches in Europe. The same form is on stone walls everywhere. It must have been of great importance to ancient mankind. There are seven regions in it, which relates to the torus and to the beating of the human heart. Later on I'll be talking about the ancient Druid mystery school on the Island of Avalon in England. To get to the top of the hill there, you have to walk through this same labyrinth, going back and forth through this motion.

While I was in England, I spoke to Richard Feather Anderson, who is an author and an expert on labyrinths, and I learned something. As part of his research, he has people walk through the labyrinth. He's discovered that when you walk through it, you are forced to move through different states of consciousness, giving you a very specific experience. It causes the life-force energy to move through the chakras in the following pattern: three, two, one, four, seven, six, five. The energy starts in the third chakra, then goes to the second, then to the first; then it jumps up to the heart (fourth), then into the center of the head to the pineal gland (seventh), then to the front of the head to the pituitary gland (sixth), and then down into the throat (fifth).

When you walk this labyrinth, unless you block the experience, you will automatically move through these changes. Even if you don't know about these things, you will go through the experiences anyway. People all over the world have found this to be true. Mr. Anderson believes that if you draw lines (the number of lines indicating which of the seven paths it is) in the order you walk the path-three, two, one, four, seven, six, five-it forms what looks like a cup. He feels that this particular labyrinth is related to the shape of the Holy Grail and to its secret knowledge.

The Egg of Life, the Second Shape beyond Genesis

The dark innermost circles show the six days of Genesis. Once the consciousness projects the first seven spheres and completes this Genesis pattern, it then continues moving in a rotational pattern from each consecutive innermost place until it completes its second vortex motion as seen by the light outermost circles. That motion in turn completes a three-dimensional shape you can hold in your hand, which looks like If you were to take and erase all the lines in the middle and certain other lines, you would see this pattern. The pattern of spheres is like what spirit would have seen had it moved outside its creation and said, "Aha, I see this thing! It looks like that". The eighth sphere is actually behind these visible spheres. If you were to connect their centers, you would see a cube. So what? Who cares? Well, the ancients did, because they were concerned with creation, life and death. They called this cluster of spheres the

Egg of Life. I'll soon show you how the Egg of Life is the morphogenetic structure that created your body. Your entire physical existence is dependent on the Egg of Life structure. Everything about you was created through the Egg of Life form, right down to the color of your eyes, the shape of your nose, how long your fingers are and everything else. It's all based on this the form.

The Third Rotation/Shape: The Fruit of Life

The next vortex is the third rotation. The spheres in this vortex are centered at the innermost places in the perimeter of the previous round, as shown by the six arrows here. So when spirit rotates in this third vortex, you get the gray rings shown here. Then you notice a new relationship where the six circles touch the center one and each other. If you took seven pennies and pushed them together on a table, they would look like that.

This third rotation is an extremely important relationship in the creation of our Reality. When you look carefully at the Flower of Life, you see these seven circles that touch each other. There are nineteen circles in the Flower of Life, and they're surrounded by two concentric circles. For some reason, that image is found all over the world. The question is, why did they do that all over the world and stop at nineteen circles?

It's an infinite grid and could have been stopped anywhere. The only place on the whole planet where I've seen them go out beyond those nineteen circles was in China, where they made room-divider screens. One of the most famous patterns they used on those screens was the Flower of Life. They made it in a rectangular shape, carrying it all the way out to the edge.

But in all others that were found, you would usually see just the Flower of Life pattern. This is because when the ancient beings realized what the other component was and how important it was, they decided to make it secret. They didn't want people to see this relationship I'm about to show you. It was so sacred and important that they just could not allow it to become common knowledge. It was appropriate at that time; however, now we either use the information or fall further into the darkness.

Notice that in the Flower of Life pattern you see many incomplete circles, which, of course, can also be spheres. If you complete all of these circles, then the secret would unfold. This was the ancient's way of coding the information. The additional circles/spheres that extend beyond the original Flower of Life pattern inside the large gray ring in complete all the incomplete circles at the edge of that pattern.

As soon as you complete these spheres, with one more step you'll have the secret: Go to the innermost places of the perimeter, shown by the arrows, and rotate the next vortex. When you do, you get the pattern of thirteen circles, shown here by the smaller gray circles, including the center. When it's extracted from the rest of the pattern, it looks like. This pattern of thirteen circles is one of the holiest, most sacred forms in existence. On Earth it's called the Fruit of Life. It is called the fruit because it is the result, the fruit, from which the fabric of the details of the Reality were created.

So the small petty mind is over critical because it is over critiical of itself. When you harbor fears and self doubts you transmit them to all you see.

You Criticize everything except Yourself.

This book is designed to shock and stun you to set your Mind and Spirit Free.



*Desire ' Delicious
Dubounet*

Combining Male and Female to Create Metatron's Cube, the First Informational System

Now, all the circles in this pattern are female. And there are thirteen ways, with these thirteen circles, that you can superimpose male energy-in other words, straight lines. If you superimpose straight lines over this in all thirteen ways, you'll come up with thirteen patterns that, along with the Egg of Life and the torus, create everything in existence. The Egg of Life, the torus, and this Fruit of Life, a total of three patterns, create everything in existence without exception-at least I have not been able to find an exception. I'll give you what I've learned; obviously I cannot show you everything, but I'll show you enough to convince you this is true. I'm going to call these informational systems. There are thirteen informational systems associated with the Fruit of Life pattern. Each system produces a vast and diversified amount of knowledge. I'm going to show you only four of those. I think that's enough.

The simplest system comes forth by simply connecting all the centers of the circles with straight lines. If you decided to put straight lines on this pattern, probably about 90 percent of you would think first of connecting all the entrees. If you do that, you end up with this pattern, which is known throughout the universe-everywhere-as Mutation's Cube. It is one of the most important informational systems in the universe, one of the basic creation patterns of existence.

The Seven great Polygons , The Platonic Solids

Anyone who has studied sacred geometry or even regular geometry knows that there are five unique shapes, and they are crucial to understanding both sacred and regular geometry. Two more and we can make any shape known. They're called the Platonic solids. A Platonic solid has certain characteristics by definition.

First of all, its faces are all the same size. For instance, a cube, the most well-known of the Platonic solids, has a square on every face, so all its faces are the same size. Second, the edges of a Platonic solid are all the same length; all edges of a cube are the same length. Third, it has only one size of interior angles between faces. In the case of a cube, this angle is 90 degrees. And fourth, if a Platonic solid is put inside a sphere (of the right size), all the points will touch the surface of the sphere.

With that definition, there are only four shapes besides the cube (A) that have all of those characteristics. Second (B) is the tetrahedron (tetra means four), a polyhedron that has four faces, all equilateral triangles, one edge length and one angle, and all points touch the surface of a sphere. The other simple one is (C) an octahedron (octa means eight), whose eight faces are equilateral triangles of the same size, edge length and angle, and all points touch the surface of a sphere.

The other two Platonic solids are a little more complicated. One (D) is called an icosahedron, which means it has 20 faces, made of equilateral triangles with the same edge length and angle, and all points touch the surface of a sphere. The last one (E) is called a pentagonal dodecahedron (dodeca is 12), whose faces are 12 pentagons (five sides), with the same edge length and angle, and whose points all touch the surface of a sphere. If you're an engineer or an architect, you have studied these five shapes in college, at least cursorily, because they're the basis of structures.

Their Source: Metatron's Cube

If you study sacred geometry, no matter what book you pick up, it shows the five Platonic solids, because they are the ABCs of sacred geometry. But when you read all these books—and I've read almost all of them—and ask the experts, "Where do the Platonic solids come from? What is their source?" almost everyone says they don't know. Well, the five Platonic solids come from the first informational system of the Fruit of Life. Hidden within the lines of Metatron's Cube are all five of these shapes.

When you look at Metatron's Cube, you're looking at all five Platonic solids at once. In order to see each one better, you have to do that trick again where you erase some of the lines. If you erase all the lines except certain ones, you get this cube.

Can you see the cube? It's actually a cube within a cube. Some of the lines are dotted because they would be behind the front faces. They are invisible when the cube becomes solid. Here's the solid form of the larger cube. (Make sure you see this one, because they get harder and harder to see as we go.) These are three-dimensional objects coming out of the thirteen circles of the Fruit of Life.

The Missing Lines

When I was looking for the final of the first five Platonic solid in Metatron's Cube, the dodecahedron, it took me over twenty years. After the angels had said, "They're all in there," I started to look, but I could never find the dodecahedron. Finally one day a student said, "Hey, Drunvalo, you forgot some of the lines in Metatron's Cube." When he pointed them out, I looked and said, "You're right, I did!" I thought I had connected all the centers together, but I had forgotten some of them. No wonder I couldn't find that dodecahedron, because those missing lines defined it! For over twenty years I'd assumed that I had all the lines when I hadn't.

This is one of the great problems in science, believing you have solved a problem, then moving on and using that 111form1at1oI1 to build on. Science is now having to deal with the same kind of problem around falling bodies in a vacuum, for example. It has always been assumed that they fell at the same rate, and much of our higher science is based on this fundamental "law." It has been proven wrong, yet science continues using it. A spinning ball falls much faster than a nonspinning one. Someday there will be a scientific day of reckoning.

Quasi Crystals

Later I found out about a brand-new science. This new science is going to change the technological world dramatically. Using this new technology, metallurgists believe they will be able to make metal ten times harder than diamonds, if you can imagine that. That would be incredibly hard.

For a long time when they looked into metals, they were using what's called x-ray diffraction to see where the atoms were. I'll show an x-ray diffraction photograph of this shortly. Certain specific patterns came up that revealed there were only certain kinds of atomic structures. They thought it was all there was to learn because that was all they could find. This limited their ability to make metals. Then there was a game going on in Scientific American which was based on Penrose patterns. Roger Penrose was

a British mathematician and relativist who wanted to figure out how to lay pentagon-shaped tiles and fully cover a flat surface. You cannot lay only pentagon-shaped tiles on a flat surface—there's no way to make it work. So he came up with two diamond shapes that are derivatives of a pentagon, and with those two shapes he was able to form lots of different patterns that would fit on a flat surface. It became a game in Scientific American back in the eighties to put these patterns together in new forms, which then led some metallurgical scientists who were watching this game to suspect something new in physics.

Update: According to David Adair, NASA has just made a metal in space that is 500 times stronger than titanium, as light as foam and as clear as glass. Is it based on these principles?

UPDATE: In 1998 we are beginning to open up another new science: nanotechnology.

We have created microscopic "machines" that can go into a metal or crystal matrix and rearrange the atoms. In 1996 or 1997 in Europe a diamond was created out of graphite using nanotechnology. This diamond was about three feet across, and it is real. As the science of quasi crystals and nanotechnology merge, our experience of life will also change. Look at the late 1800s compared to now.

Ultimately they discovered a new kind of atomic grid pattern. It was always there; they merely discovered it. These grid patterns are now called quasi crystals; it's a new thing (1991). They're unraveling what shapes and patterns are possible through metals. Scientists are finding ways to use these shapes and patterns to produce new metal products. And I'll bet that the pattern Macki got out of Metatron's Cube is the grand master of all, and that any Penrose pattern in existence is derived from it. Why? Because it's all Golden Mean, it's basic—it came straight out of the basic pattern in Metatron's Cube. Though it's not my business, at one point I will probably determine if it's really true. I see that instead of using the two Penrose patterns and the pentagon, it uses only one of them and a pentagon. (I just thought I'd offer that.) What's happening in this new science right now is interesting.

As this book begins to unfold, you'll discover that sacred geometry can describe in detail any subject whatsoever. There is not one thing you can pronounce with your mouth that cannot be completely, utterly and totally described, with all possible knowledge, by sacred geometry. (And we are making the distinction between knowledge and wisdom: Wisdom needs experience.)

Yet a more important purpose of this work is to remind you that you have the potential of a living Mer-Ka-Ba field around your body and to teach you how to use it. I'll continually come to places where I digress into all kinds of roots and branches and talk about every subject you can think of. But I'm going to keep coming back on track, because I'm heading in one particular direction, toward the Mer-Ka-Ba, the human lightbody. I've spent many years studying sacred geometry, and I believe you can know everything there is to be known about any subject whatsoever just by focusing on the geometries behind it. All you need is a compass and a ruler—you don't even need a computer, though it does help. You have all knowledge in you already, and all you have to do is unfold it. You simply learn the map of how spirit moves in the Great Void, and that's it. You can unravel the mystery of any subject.

To summarize, the first informational system comes out of the Fruit of Life through Metatron's Cube. By connecting the centers of all the spheres, you have five shapes—really six, because you have the central sphere, which started the whole thing. So you have six primal shapes—the tetrahedron, the cube, octahedron, icosahedron, dodecahedron and the sphere. The Platonic Solids and the Elements These six

shapes were considered by the ancient alchemists and great souls like Pythagoras, the father of Greece, to have had an element aspect to them.

The tetrahedron was considered fire, the cube was earth, the octahedron was air, the icosahedron was water and the dodecahedron was ether. (Ether, prana and tachyon energy are the same thing; they extend everywhere and are accessible at any point in space/time/dimension. This is the great secret of zero-point technology.)

And the sphere is voidness. These six elements are the building blocks of the universe. They create the qualities of the universe. In alchemy, they usually talk only about fire, earth, air and water; they seldom discuss ether or prana because it's so sacred. In the Pythagorean school, if you even uttered the word "dodecahedron" outside the school, they would kill you on the spot. That was how sacred the shape was. They wouldn't even discuss it. Two hundred years later when Plato was alive, he would discuss it, but only very carefully. Why? Because the dodecahedron is near the outer edge in your energy field and is the highest form of consciousness. When you get to the 55-foot limit of your energy field, it's a sphere. But the very next shape inside the sphere is the dodecahedron (actually, the dodecahedron/icosahedral relationship).

In addition, we live in a big dodecahedron that contains the universe. When your mind reaches out to the end of space-and there is an end-there's a dodecahedron enclosed in a sphere. I can say this because the human body is a hologram of the universe and contains the same principles. The twelve constellations of the zodiac fit inside it. The dodecahedron is the terminating point of the geometries, and it's very important. On a microscopic level, the dodecahedron and the icosahedron are the relational parameters of the

DNA, the blueprint of all life

You can relate the three columns in this figure to the Tree of Life and to the three primary energies of the universe: male (on the left), female (right) and child (center). Or if you go right down to the fabric of the universe, you have the proton on the left, electron on the right and neutron in the center. This central column, which is the creating one, is the child. Remember, we went from an octahedron to a sphere to begin the process out of the Void. It is the beginning process of creation, and it is found in the child, or central column.

The left column, holding the tetrahedron and the cube, is the male component of consciousness, the left side of the brain. The faces of these polygons are triangles or squares. The center column is the corpus callosum, which links the left and the right sides. The right column, holding the dodecahedron and the icosahedron, is the female component of consciousness, the right side of the brain, and the polygon faces are made up of triangles and pentagons. Thus the polygons on the left have three- and four-sided faces and the shapes on the right have three- and five-sided faces.

In terms of the Earth's consciousness, the right column is the missing component. We have created the male (left) side of Earth's consciousness, and what we are doing now is completing the female component for wholeness and balance. The right side is also associated with Christ or unity consciousness. The dodecahedron is the basic form of the Christ consciousness grid around the Earth. The two shapes in

the right column are what are called duals of each other, meaning if you connect the centers of the faces of a dodecahedron with straight lines, you get an icosahedron; and if you connect the centers of an icosahedron, you again get a dodecahedron. Many polyhedrons have duals.

The Sacred 72

In Dan Winter's book, *Heartmath*, the DNA molecule is shown to be constructed by the dual relationship of dodecahedrons and icosahedrons. One can also see the DNA molecule as a rotating cube. When you rotate a cube through 72 degrees in a particular pattern, it makes an icosahedron, which is in turn a dual with the dodecahedron. So there's a reciprocal pattern going up the DNA strands: the icosahedron, then the dodecahedron, the icosahedron, continuing back and forth. This rotation through the cube creates the DNA molecule. It has been determined that this is the exact sacred geometry behind the DNA, although there may be further hidden relationships.

This 72-degree angle rotating in our DNA connects with the blueprint/ purpose of the Great White Brotherhood. As you may know, 72 orders are associated with the Great White Brotherhood. Many people speak of the 72 orders of angels and the Hebrews speak of the 72 names of God. The reason for 72 has to do with the way the Platonic solids are constructed, which is also related to the Christ consciousness grid around the Earth. If you take two tetrahedrons and superimpose them (though in different positions), you get a star tetrahedron, which, from a different view, is nothing but a cube. You can see how they're interrelated. In a similar manner, you can also put five tetrahedrons together and make an icosahedral cap. If you make twelve icosahedral caps and put one on each face of the dodecahedron (it would require 5×12 , or 60 tetrahedrons to create a dodecahedron), it would be a stellated dodecahedron because a point comes out of the center of each face. Its dual is the 12 points in the center of each face of the dodecahedron, which forms an icosahedron. The 60 tetrahedrons plus the 12 points of the centers equal 72-again, the number of orders associated with the Great White Brotherhood. The Brotherhood actually functions through the physical relationships of this stellated dodecahedron/icosahedron form, which is the basis of the Christ consciousness grid around the world. In other words, the Brotherhood is attempting to bring out the consciousness of the planet's right brain.

The original order was the Alpha and Omega-Order of Melchizedek, which was formed by Machiventa Melchizedek about 200,200 years ago. Since then 71 other orders have been created. The youngest one is the Brotherhood of the Seven Rays in Peru/Bolivia, the seventy-second order.

Each of the 72 orders has a life pattern like a sine-wave curve, where some of them come into existence for a certain length of time and then disappear for a while. They have biorhythms just as a human body does. The Rosicrucians, for example, are on a hundred-year cycle. They come out for a hundred years and then disappear totally for a hundred years-they literally disappear off the face of the Earth. Then a hundred years later they're back in the world and functioning for another hundred years. They're all on different cycles, and they're all functioning together for one purpose-to return Christ consciousness back to this planet, to set up this lost feminine aspect of consciousness and bring balance between the left and the right side of the planet's brain. There's another way to look at this that is really extraordinary. When we talk about England,

Crystals Grounding Our Learning

Now we're going to take this abstract information that doesn't really seem to apply to us in our everyday lives, and we're going to tie it to our everyday experience. Some of this is not in everyday experience, but we can more or less understand and connect with the subjects.

First I'm going to ground this information to crystals. There are lots of other areas of nature I could use, but it's so obvious in crystals that anybody can see it. I could use viruses or diatomaceous earth. I could show it in a lot of things, but crystals are good because people like them.

To begin looking at these crystals, let's first examine this x-ray diffraction pattern. When you shoot x-rays down the C axis of the atomic matrix of a crystal or metal, you'll get these little dots showing you exactly where the atoms are located. In this case, this is a beryl crystal that actually displays the Flower of Life pattern. The beryl crystal uses the pattern to arrange its atoms and form this specific crystal. It's really amazing that these little atoms simply line themselves up in space, often with enormous distances between them. These microscopic spaces are relatively vast, like between the stars in the night sky. The atoms perfectly align themselves in cubes and tetrahedrons and all kinds of geometric shapes. You can see how the atoms have arranged themselves in a cubical design. It's interesting that in all the various forms manifested in the Reality, the atoms themselves are spheres. This simple fact has been overlooked by most researchers, but the sphere is the main form that everything came from in the beginning. It is important in understanding creation.

The entire fabric of everything in our existence is made up of "marbles" -all different sizes of spheres. We're sitting on a sphere, the Earth, and spheres are rotating around us.

The Moon, Sun and stars are all spheres. The whole universe, from macrocosm to microcosm, is made up of little spheres in one way or the other. The light waves moving through space are all spheres. We think of a light wave as making waves through space, but it's much more complex.

An electrical field spins one way around it and a magnetic field rotates at 90 degrees to the electrical field, and they expand in spherical patterns.

Imagine a cube in deep space, and see a bright light flashing from it, going out in all directions, 360 degrees. What do you have? Do you have a cubical light-wave energy field moving away from it? At first thought you might say it would be an expanding cube, getting bigger and bigger and bigger.

But that's not what happens. Light waves move radially away from their source at 186,200 miles a second, so when a light wave moves from the surface of a cube I hold in my hand, in one second the light from the face of the cube is already 186,200 miles away. And the wave that moved off a corner of the cube, which is a little farther away from the center than the face, is, in one second, 186,200 miles away from the center plus maybe a fraction of an inch. If you could see a fraction of an inch at 186,200 miles, you'd have super vision. And that's only in one second; two seconds later the form has expanded twice that far, and a minute later it's enormous.

So you have a sphere moving away from something that originated as a cube. If the object happens to be really big, then the light wave first tends to take the shape of the object, but it slowly turns into a sphere as it moves away and the object becomes smaller and smaller relative to that light field.

So what you have out there is a bunch of light spheres, moving away in all directions and interconnecting with each other. When you see light coming directly toward you, it's white. But if it's not moving directly toward you, it's black. In fact, the entire night sky is filled with brilliant white light, but we see the light only when it's coming toward us. We don't see the light waves that move sideways from us; we just see black. If we could see it all, it would be blinding. Light is everywhere, and there is no place in space where it is not. The sphere is literally everywhere.

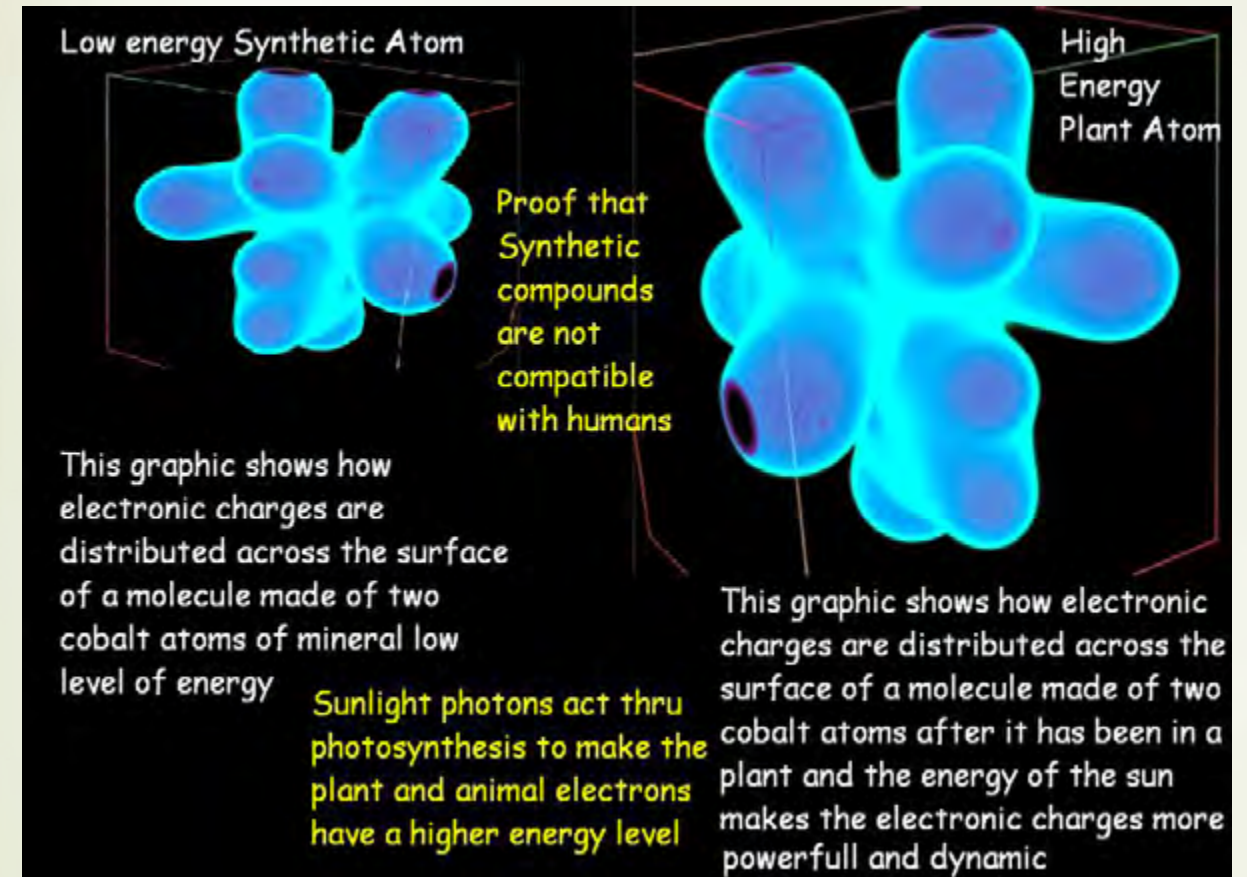

Electron Clouds and Molecules

Atoms are also made up of spheres. If you look at the hydrogen atom, the proton is compacted in the center and the electron is way out there orbiting the proton. If the proton were the size of a golf ball, the electron would be about a football field away and that electron is moving real fast!

I remember that when I was studying physics, I could not believe that the little electron, which is a pinpoint you cannot even see, is moving around and around in some microscopic space at nine-tenths the speed of light. This means that the electron travels around the proton about 170,000 miles every second, around something you can't even see! My mind was totally hoggled! I went home and lay on the bed and stared at the ceiling for a long time. That was just inconceivable to me. The little electron moves around so fast that it appears as a cloud. In fact, they call it an electron cloud. There's only one electron, but it's moving so fast that it appears to make a sphere around the central proton. It's like a television screen, where there's only one electron beam moving across that screen at any one moment, moving carefully and

intentionally down the screen, zigzagging back and forth until it gets all the way down to the bottom, then starts all over again.

It's doing this so fast that you see a very believable image. So spheres are the primary component of the Reality we're experiencing. Although an electron orbit describes a sphere, it can also describe other patterns, such as a figure eight. Physicists have been able to calculate this only for hydrogen, and so far they're just guessing about the rest. An atom is called anion if it has too many or too few electrons and has either a positive or a negative charge. So primary characteristics of an atom are how big it is and what its charge is. These two main factors determine whether or not different atoms will fit together into molecules. There are other subtle factors involved, but size and charge are primary. Figure 6-31 shows how atoms combine. These were the primary patterns known for a long time, until they figured out about quasi crystals. The atoms on this chart have several varieties. A shows a linear pattern with a smaller atom in the middle. B shows a triangular pattern of three with a little atom in the middle. The little atom can literally either be there or not be there. C shows a tetrahedral pattern, with one atom in the middle, or not. D shows an octahedral pattern, and E shows a cubical pattern. Now, because of new scientific information, we can add icosahedral and dodecahedral patterns.

Atoms always line up in specific ways when they crystallize. They form into, say, a cube, and then that cube puts another cube next to itself and another cube next to it, and soon you get one cube connected to another, connected in turn to another cube and so on, forming what is called a lattice. There are all kinds of ways that atoms can join. The resulting molecules are always associated with sacred geometry and the five Platonic solids. It makes you wonder how those little atoms know to go only into those certain places, especially when they get very, very complex!

Even when you get into this complicated molecule and break it down, you see the shapes in it, and they always revert to one of the five Platonic solids-it doesn't matter what the structure is. No matter what you call it-metal, crystal, anything else-it will always come down to one of these original five shapes. I'll show you more examples as we get further into this.

The Six Categories of Crystals

Now we'll get into crystals. There are at least a hundred thousand different kinds of crystals. If you've ever been to the Tucson Gem and Mineral Show, you know exactly what I'm talking about. This show takes over eight or ten hotels, with every room in the multistory hotels filled with Crystals. In the auditorium you'll see all the gems. There are lots and lots and lots of different kinds of crystals. And more are being found; almost every year there are eight, nine, ten brand-new crystals never known before. But no matter how many crystals there are, they can all be put into six categories: isometric, tetragonal, hexagonal, orthorhombic, monoclinic and triclinic. And all six of these systems used for organizing all known crystals are derived from the cube, one of the Platonic solids. It's a matter of which angle you are viewing the cube from-the square, hexagonal or rectangular view as opposed to the normal 90° cubic angle. Now, this is where Fluorite is found in just about any conceivable color you can think of, including clear. There are two primary fluorite mines in the world: one is in the United States and the other in China. Fluorite is found with two totally different atomic structures: one is octahedral and the other cubical.

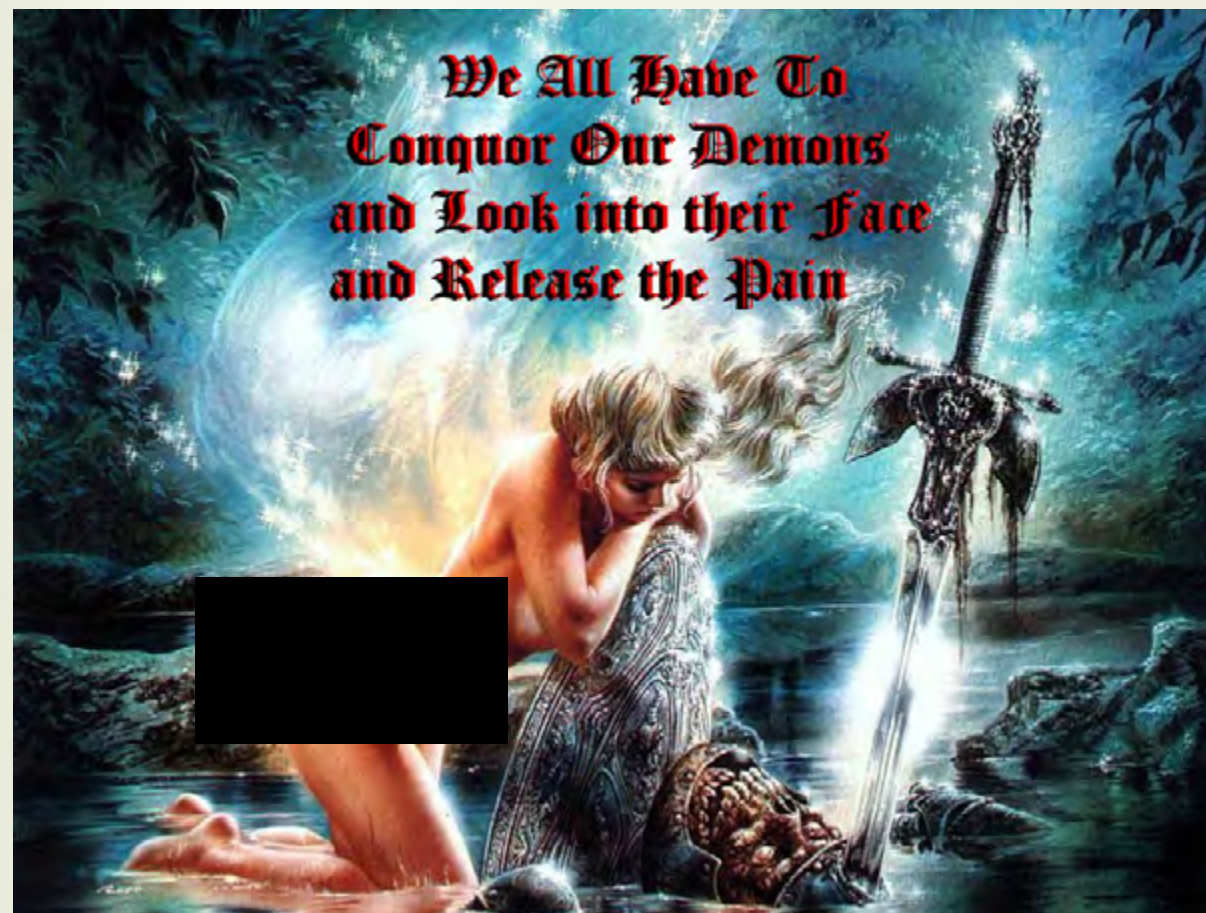

This purple fluorite crystal is made up of tiny cubes all clumped together. They were not cut that way, they grew that way. The clear fluorite crystal is an actual octahedron. It was not cut that way, but in this case it didn't grow that way, either. It usually comes in sheets, and if you drop it or strike it, it breaks along the weakest bonds, which happen to be octahedral, because the atoms are in an octahedral lattice.

If I were to drop it onto a hard surface, it would break into a whole bunch of baby octahedrons.

But what's especially interesting is that it's been discovered that fluorite will grow from one shape to the other-from cubical to octahedral and back again. In its natural state, given enough time, a cubical crystal will someday become octahedral. And given enough time, an octahedral fluorite crystal will become cubical. They oscillate over time, first becoming one, then the other, back and forth over very long periods of time. Geologists have found some fluorite crystals in the process of change, but they could not understand how they oscillated like that.

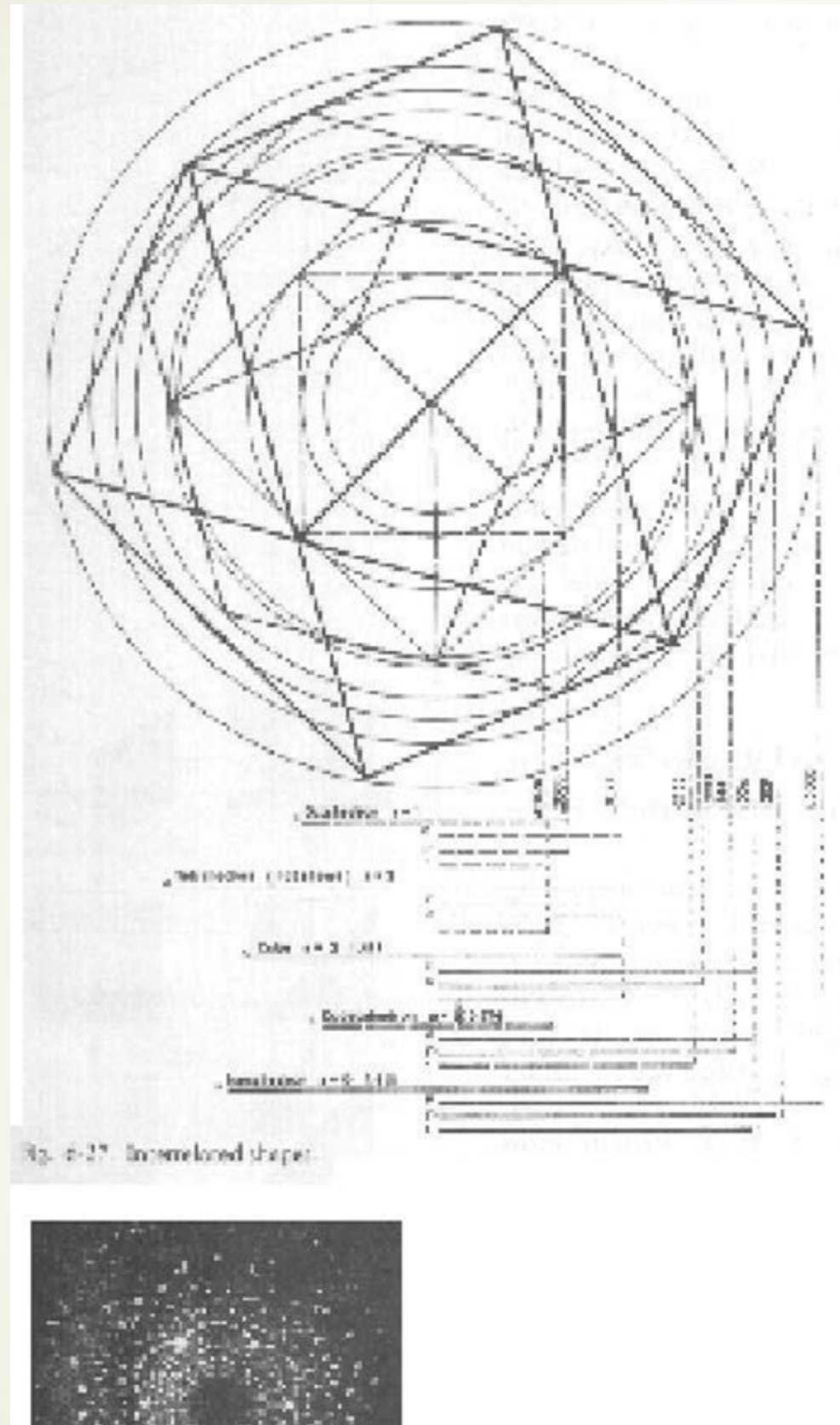

Truncating Polyhedrons

One geology book tried to explain how fluorite changes. At the bottom right you see a cube. If you were to cut off its corners by the same amount, it's called truncating. You can truncate any polyhedron, meaning any of these many-sided shapes. When you do that (in this case a cube), you can cut off either the corners, the edges or the faces, as long as you cut them all the same. If you truncate this cube by cutting the corners at 45 degrees all the way around, you get the next shape to its left. If you truncate it again in exactly the same way, you come up with the next shape to the left. If you do it once more, you get an octahedron (on the far left).

You can go back the other way, truncating the corners of the octahedron, and come back through the whole procedure until it turns back into a cube. This was the geology book's attempt to explain how in the heck fluorite changes shapes like that. The book actually explains only how this change could take place geometrically. But in truth, something far more amazing takes place when fluorite changes. The ions actually rotate and expand or contract to become a different lattice! It's much more complex than the book shows.

A little side note: If you look inside a point-truncated tetrahedron made of glass or crystal or even mirrors, it will reflect the light. The mirrored reflection inside it is a perfect icosahedron. Check it out. You can go on and on with this. You'll see some that look really strange, like they couldn't possibly be based on anything logical, but all you have to do is a little geometry, and every time you will find out that it's derived from one of the five Platonic solids. There are no known exceptions.

No matter what the crystal pattern is, it's always based on a Platonic solid. Crystal structures are a function of the five Platonic solids that came out of the Fruit of Life, out of Metatron's Cube. If you want to see more of these crystals, you can find plenty in the *Rocks and Minerals* book by Charles A. Sorrell. This pattern happens to be related to our consciousness, to the very nature of who we are.

Buckminster Fuller's Cube Equilibrium

This is what that shape looks like three-dimensionally. It's called a cuboctahedron or vector equilibrium. You can see that it's originally a cube, but if the angle at point A were continued upward, it would form an octahedron. It's both at once, an octahedron and a cube. It doesn't know which one it is; it's somewhere in the middle. When Buckminster Fuller found this polyhedron, he became almost preoccupied with it. He thought that the cuboctahedron was paramount, the greatest shape that ever was in creation, because it does something that no other known shape does.

It was so important to him that he gave it a brand-new name: the vector equilibrium. He discovered that this shape, through different rotational patterns, turns into all five of the Platonic solids! This one shape seems to have them all contained within itself.

If you find this interesting, buy this toy [see the reference section] and play with it. It will answer all your questions if you let it.

SCIO

CE measures treats



The SCIO Universal Electrophysiological Biofeedback System can safely measure over the skin (transcutaneous) skin electro-potential down to the micro-volt range. Virtual and mathematical calculations of the attained data can provide CNS (Central Nervous System) biofeedback data, so as to include (simple EEG [electroencephalography], 3-pole ECG [simple stress electrocardiography], global transcutaneous EMG [electromyography].

The system can measure the transcutaneous skin resistance by application of a medical safe micro-current voltametric pulse, so as to measure GSR [galvanic skin response] and TVEP [transcutaneous voltametric evoked potential].

The system is designed for the detection of stress and reduction of stress through CNS biofeedback data or stress lifestyle questionnaires. The stress and lifestyle questionnaires provide educational feedback through library referenced functions. And the device can be used for the treatment of muscular re-education from injury, muscle weakness, sport muscular enhancement or various dystonia. The applied voltametric pulse can be used to detect and affect in established modalities such as pain (TENS [transcutaneous electro nerval stimulation]), trauma/wound healing, charge stability imbalance, redox potential and electrophysiological reactivity.

The device after 20 years of use is quality tested, clinically evaluated and scientifically validated as safe and effective.

If you need more information on the SCIO and purchase details please get in touch with us

Maitreya Kft.
 tel: +3613036043
 web: www.qxsubspace.com
 e-mail: info@qxsubspace.com

Subspace Treatise on the Collective Unconscious of the Universe

The 26 Shapes

From my way of thinking, the first five Platonic solids are the first five notes of the pentatonic scale. The octave has seven notes, the last two corresponding to the cuboctahedron (A) and the rhombic dodecahedron (B) shown in Figure 6-43. Five additional shapes form the chromatic scale, and there's a thirteenth one, the return. Thus there are 13 polyhedrons that form the chromatic scale of music. From those 13, 13 more are formed that are the same, only stellated, to total 26 shapes-two octaves within each other. In terms of form, those 26 shapes are the key to all the harmonics of the Reality.

Some of you may know of Royal Rife, the man who was trying to cure cancer through electromagnetic fields (EMF) such as light, which I believe is absolutely possible and has been done. Rife knew of ? of the 13 (or possibly 26) frequencies. The ones he published were incorrect, but he purposely did that. Those he published cause cancer, though if they're shifted slightly in a certain mathematical way, they return to the original frequencies, and each frequency destroys most or all of a specific virus or bacterium. (Now we think of any frequency treatment as Rife, as the extent of frequency therapy is endless) However, Rife only knew part of the equation. If he had known the sacred geometry we now know, he could have come up with all 26 forms and eliminated any virus in existence. It doesn't matter how many AIDS viruses there are, there's nothing to finding a solution.

There are a maximum of 26 templates, and the right frequencies will eliminate every single virus (or bacterium). Because every virus is a polyhedron-structurally, they look just like the polyhedrons. There are various ways you can deal with them. You can either blow them up through certain harmonics of EMF, or you can match them. If you can match them, you can couple with them, much like an antivirus does. Or you can simply make them nonexistent by creating a waveform that's a mirror image of what they are. There are lots of ways to work with AIDS, but one primary key is understanding that there are a maximum of 26 geometries associated with it. Crystallized water-ice crystals-form these hexagonal patterns we call snowflakes. You can see the relationship to the Flower of Life.

Over and over and over again you will find this relationship of 3D patterns to the geometries that come out of this one central Flower of Life pattern.

The Periodic Table

This is an interesting version of the Periodic Table of the Elements, because it shows that every element, with a few exceptions that cannot be determined because they will not crystallize, is related to the cube. One of these few exceptions is fluorine, because fluorine reacts with almost nothing. It's one of the most inert gases. But on almost all the other elements we find this cubical relationship, except the fourth-dimensional atoms that fall outside the natural Table of Elements and those that are synthetic or man-made. They don't happen naturally in nature. Each atomic element has an associated crystalline structure. In every single case scientists have found that the different crystalline structures associated with atoms can be reduced to the structure of a cube. You might have noticed that the cube seems to be more important than the other polygons. For example, crystals are divided into six different categories, but the cube is the basis of all of them. In the Bible it says that the throne of God is so many cubits in different directions. When you make one, it's a cube. The pharaohs in Egypt sat on a cube.

PERIODIC TABLE
Atomic Properties of the Elements

NIST
National Institute of Standards and Technology
Technology Administration, U.S. Department of Commerce

Physica Laboratory
physics.nist.gov

Standard Reference
Data Group
www.nist.gov/srd

Frequently used fundamental physical constants
For the most accurate values of these and other constants, visit physics.nist.gov/constants

1 second = 9 192 631 770 periods of radiation corresponding to the transition between the two hyperfine levels of the ground state of ^{133}Cs

speed of light in vacuum c 299 792 458 m s⁻¹ (exact)
Planck constant h 6.626 069 57 × 10⁻³⁴ J s (exact)
elementary charge e 1.602 176 634 × 10⁻¹⁹ C (exact)
electron mass m_e 9.109 382 91 × 10⁻³¹ kg
proton mass m_p 1.672 621 63 × 10⁻²⁷ kg
fine-structure constant α 1/137.035 999 074
Rydberg constant R_∞ 10 973 731.568 160 × 10¹⁰ m⁻¹
Boltzmann constant k_B 1.380 658 × 10⁻²³ J K⁻¹

Solids
 Liquids
 Gases
 Artificially Prepared

1	2											13	14	15	16	17	18
1	2											3	4	5	6	7	8
3	4	5	6	7	8	9	10	11	12	13	14	15	16	17	18		
4	5	6	7	8	9	10	11	12	13	14	15	16	17	18	19		
5	6	7	8	9	10	11	12	13	14	15	16	17	18	19	20		
6	7	8	9	10	11	12	13	14	15	16	17	18	19	20	21		
7	8	9	10	11	12	13	14	15	16	17	18	19	20	21	22		

Atomic Number: 58
 Symbol: Ce
 Name: Cerium
 Atomic Weight: 140.116
 Ground state Configuration: [Xe]4f¹5d¹6s²
 Ionization Energy (eV): 5.5387

Based upon ^{12}C Δ indicates the mass number of the most stable isotope. For a description of the data, visit physics.nist.gov/data NIST SP 968 (September 2003)

The Key: The Cube and the Sphere

Well, the cube is different from the other Platonic solids because it has one characteristic the others do not-except for the sphere, which also has the same characteristic. Both the sphere and the cube can perfectly contain the other four Platonic solids and each other symmetrically, by their surface, assuming you have the right sizes. The cube is the only Platonic solid with this special characteristic: You can take a sphere, slip it inside a cube, and it will touch the six faces perfectly and symmetrically. And a tetrahedron will slide right down one of the axes and become the diagonals of the cube, fitting perfectly and symmetrically. A star tetrahedron will also fit perfectly inside a cube. The octahedron is actually the dual of the cube; if you connect the centers of the adjacent cube faces, you get an octahedron. That one is easy.

When you get to the last two Platonic solids, it doesn't look like they could fit symmetrically into the cube and the sphere, but they do. It is a little difficult to show here, but you can see for yourself. Using a real model, just find where both the icosahedron and the dodecahedron have six edges in the planes of the cube, and you have it. You will see how they slide into the faces of the cube. You can see how the other four Platonic solids fit symmetrically into the cube and the sphere. What is important here is that only the sphere and the cube have this capability. The cube is the father, the most important male form. The sphere is the mother, the most important female form. So in the entire Reality, the sphere and the cube are the two most important forms and will almost always dominate when it comes to primary relationships in creation.

It was for this reason that a man named Walter Russell did some work long ago that was absolutely phenomenal. I don't believe he knew anything about sacred geometry-he was sacred-geometry illiterate, to my knowledge. Yet he intuitively grasped it in his mind. And when the images were happening in his mind, he chose the cube and the sphere as the main geometries to talk about what he understood. And because he chose those two forms and not others, he was able to go far. If he had selected any others, he would have made a big mistake and would have been unable to do the work he did.

Crystals Are Alive!

This amplifies my thoughts about crystals being alive. Before I taught this course I used to give courses on crystals, back in the early or mid '80s, I guess. And I discovered-not through giving the courses, but through my actual interaction with the crystals themselves-that these crystals are alive. They are living and conscious. I was able to communicate with them, and they communicated with me. Through these interchanges I found out all kinds of things. The more I lived with them and learned how to connect with them, the more I discovered just how conscious they were. It was one of the most interesting awakenings in my life. One time I was in San Francisco giving a course to about thirty people, and I was saying this very thing, "These guys are alive." Everybody was listening and saying, "Yeah, yeah, yeah." Then one person said, "Prove it." I said, "Okay," then I quickly thought up something to do. I gave everybody a piece of paper and a pencil, and said, "We're going to grab a crystal at random." I selected a crystal that nobody had seen-actually took one and kept it hidden. We didn't let anybody see it. Then I said, "Now, nobody gets to examine this crystal or even see what it is. You're just going to put it on your forehead, and you have one second-that's it. You're going to ask the question, Where are you from? The very first

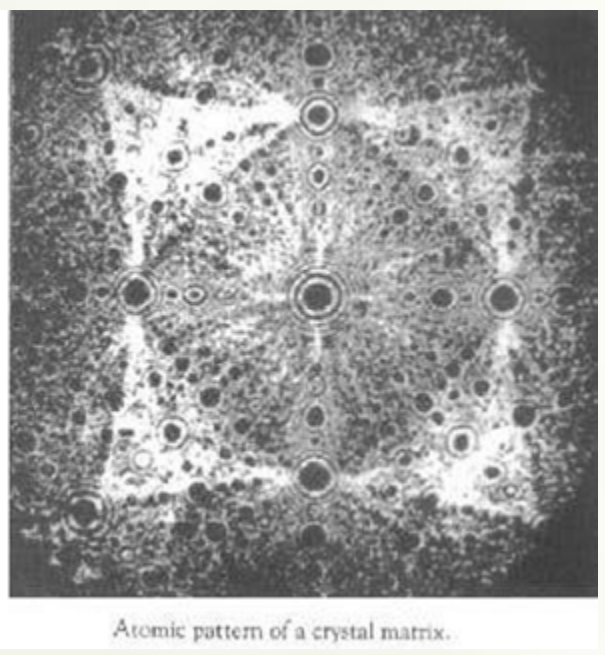

Atomic pattern of a crystal matrix.

word that comes in, write it on a piece of paper and fold it up so no one sees it. Just take the crystal, ask the question, hand it to the next person, then write down what you get." That was the only way I could think of to prove it. We passed that crystal around to thirty people, and everybody wrote down an answer. Then we looked to see what we received. And every single person had "Brazil" written down! What are the odds of that? Crystals have phenomenal abilities. They affect people in all kinds of ways. Katrina Raphaell has written a lot about this in her books, but many other people have also learned about the abilities of crystals over the years.

Many ancient beings and civilizations were also well aware of this. Crystals don't just happen as the result of a chemical reaction either; they grow. When you study how crystals are formed, they grow very much like people in lots of ways. An aerial view of your energy field is in part simply the Flower of Life pattern, which is hexagonal in nature. Our fields grow hexagonally, just as crystals do. Though the silicon molecule is a tetrahedron, when it forms quartz it links with another silicon tetrahedron to form a cube. Then it throws out a long line of little star tetrahedrons or cubes to form a row. Then the row begins to spin, changing direction exactly at 60 degrees to form a hexagon, the same structure seen around the human body from above.

Crystals have genders. They're either male or female or both. If you know what to look for, you can look at a crystal and see which way it's rotating. Find the lowest window or face and look to see where the next face is. If it is on the left, then it is rotating clockwise, and that crystal is female. If it is on the right, then it is rotating counterclockwise, and it is male. If there are faces on both sides at just about the same height, you should see two spirals moving around this crystal in opposite directions, and that crystal would be bisexual.

Often two crystals are joined at the base and wrap somewhat around each other. These are called twinned crystals, and these are almost always male and female. It's rare for them to do it differently.

The Future Silicon/Carbon Evolutionary Leap

The sixth element on the Periodic Table is carbon. It is the most important element as far as we're concerned, because it's us. It makes up organic chemistry; it is the element that makes our bodies possible. We have been told that carbon is the only living atom on the Periodic Table, that only organic chemistry produces life, nothing else. But that's definitely not true. They suspected this as far back as the '80s when scientists began to study these things.

They realized that silicon, which is directly below carbon on the chart (one octave apart) also exhibits the principles of life. There appears to be no difference. Silicon forms certain chains and patterns. These are only a few. Silicon makes endless patterns, and it will react chemically with almost anything that comes near and form something with it. Carbon has the same ability, making endless forms and chains and patterns and reacting chemically with almost anything nearby. This is the primary characteristic that makes carbon a living atom. On a chemical level, it appears that there should also be silicon life forms. After this was discovered, several science fiction movies were made in the '80s based on the belief that there might be silicon life forms on other planets. There were a bunch of scary movies about living crystalline structures. They didn't know when they were making those movies that there really are silicon

life forms right here on this planet. Some of these were recently found several miles deep in crevices in the ocean. Silicon sponges were found—live sponges that grow and reproduce, demonstrating all the principles of life, and with not a single carbon atom in their bodies! Here we are, sitting on Earth, which is over 7000 miles in diameter. Its crust, 30 to 50 miles thick, is, like an eggshell, made up of 25 percent silicon, but because silicon reacts with just about anything, the crust is actually 87 percent silicon compounds. That means that the Earth's crust is almost pure crystal, 30 to 50 miles deep. So we're on this huge crystal ball floating through space at seventeen miles a second, totally oblivious of the connectedness of carbon life with silicon life. It would seem that silicon and carbon must have a very special relationship. We carbon based beings are living on a crystal ball made of silicon, our crystal planet, looking for life outside ourselves in outer space. Perhaps we should look to-ward our feet.

Now, think about computers and the modern world. We're making computers that are performing all kinds of incredible things. The computer is rapidly moving humankind into a new experience of life on Earth. What are computers made of? Silicon. And what is the computer industry trying to do as fast as it can? Make self aware computers. We're very close to accomplishing this, if we haven't already. I feel sure that very soon we will have self-aware computers. So here we are, carbon-based life forms creating silicon-based life forms, and we're interacting with each other. When we have self-aware silicon-based computers, nothing will ever be the same again. We're going to have two different life forms/components of the Earth connecting with each other, and the speed with which we will evolve at that point, aside from everything else, is going to be very, very fast—faster than anything we would normally expect. I believe that this will come true in this lifetime.

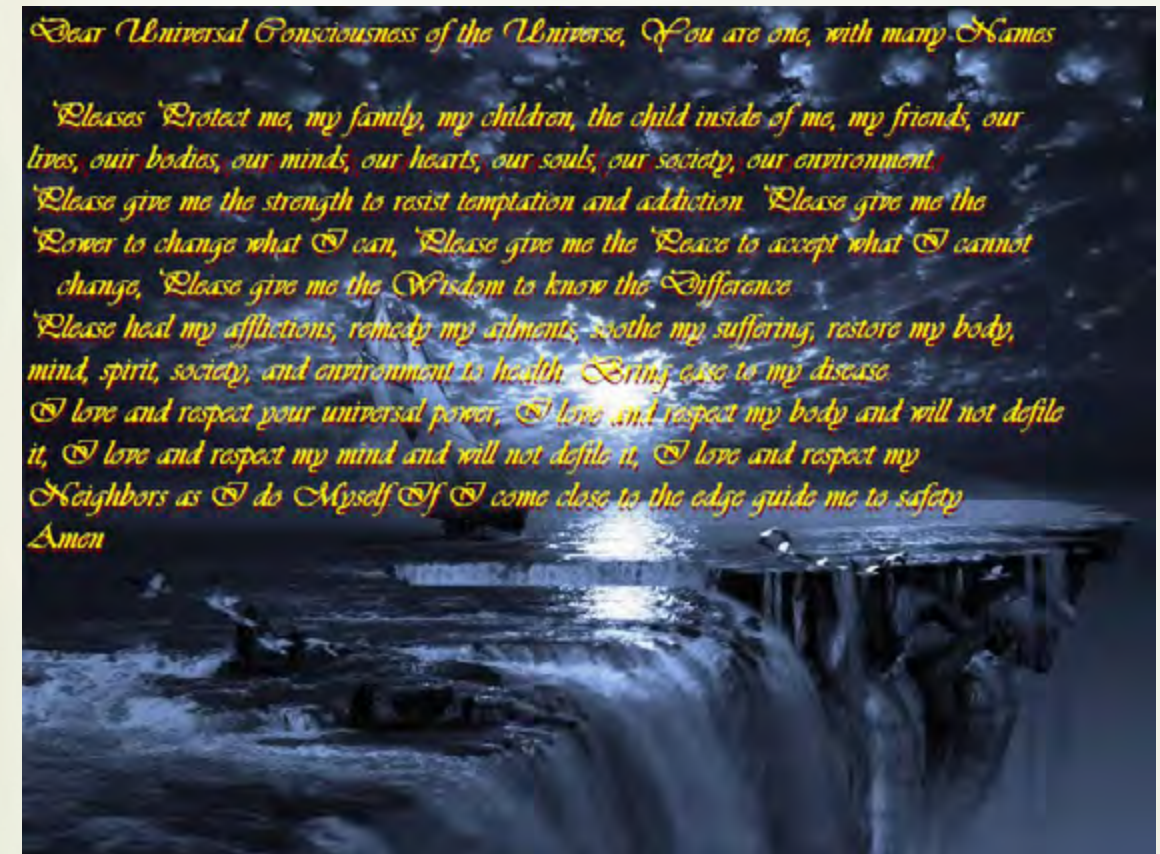

The Measuring Stick of the Universe: The Human Body and Its Geometries

Geometry within the Human Body

It's easy to see how the five Platonic solids influence the structural patterns of crystals and metals. Metals also have atomic lattices. It's simple to see the geometrical relationship of these types of molecules, but when you look at yourself or at a baby being formed, it's much more difficult to see how this kind of geometry could have anything to do with us at all. Yet it does. In the beginning of your life in the womb, you were nothing but geometrical forms. In fact, all life forms-trees, plants, dogs, cats, everything-have the same geometrical and structural patterns running through them that ran through you when you were microscopic.

Their very life and structural support depend on the forms. In fact, all life forms are these geometrical patterns, but it is not apparent to the casual eye. These geometrical relationships are important to perceive, not only so the left brain can realize the unity of all life, but for another reason: so that we can understand these ElectroMagnetic structural patterns around our body and begin to re-create the living Mer-Ka-Ba around us.

The Number Twelve

When you were first learning about human biology, you were probably told that it takes one sperm for conception to occur. That isn't true, according to Time magazine, even though most textbooks still state this. It is now known that the ovum must be absolutely saturated with hundreds of sperm, or conception is not even possible. Second, out of those hundreds, ten, eleven or twelve must come together in some kind of pattern on the surface-a pattern they're still trying to figure out-that allows the eleventh, twelfth or thirteenth sperm to enter the ovum. One sperm cannot get through the membrane without the other ten, eleven or twelve. It's not possible except under unnatural conditions, where a human manipulates the conception.

This image brings up what was possibly hidden in the life of Jesus. Jesus came here to a round ball called Earth, which was saturated with people. The first thing he did was gather twelve males together, no females. Jesus-from my point of view and from his, I'm sure, because he did it-could not have done what he did without the twelve disciples. Seldom does anyone wonder why he gathered those twelve disciples together. He absolutely had to have them. If we are right, he could have done it with ten or eleven, but he chose twelve. I believe that the number of sperm that join to allow the one sperm to enter the egg determines the sex-and Jesus chose twelve.

Prior to Jesus' time, in Greece, near the area of his ministry, people saw the Earth as a sphere. Right after that they began to see the Earth as a cube and flat. Then 400 years ago, Copernicus came along and changed it back to a sphere. So people's perception of the Earth went from a sphere to a cube and back to a sphere. Exactly the same thing (sphere to cube to sphere) goes on during conception, only at a much faster rate. I don't know if this analogy is true or not, but it sure does look like it.

The Sperm Becomes a Sphere

Anyway, the little sperm gets in through the zona pellucida with the help of the other sperm and then starts swimming toward the female pronucleus.

The first thing that happens is that the sperm's tail breaks off and disappears-it's just gone. Next, the tiny sperm head expands and becomes a perfect sphere, which is the male pronucleus. It becomes exactly the same size as the female pronucleus, and it contains the other half of the necessary information. The words "exactly the same size," I believe, are very important when you look at the next figure. Next, they pass through each other and form a geometrical relationship called the vesica piscis. It's not possible for two spheres to pass through each other and perfectly coincide without forming a vesica piscis. This means that at that exact moment, the male and female pronuclei form the image of the first motion of the first day of Genesis, and literally all the information of the Reality (and light) is contained in that geometry.

It's so simple. That image could not be formed unless these two pronuclei were the same size. It's for that reason I believe that the female determines which sperm will enter. Science proved around 1992 that the determining factor for which sperm will enter is the female. She selects the one to allow in.

Just as everybody in this room has a different projection length into a dark space or into the Void, each little sperm also has a different-size sphere around it. She's not going to let him in unless his size is identical to hers. If it's a matching key, okay; if it's not, forget it. This could explain why many people who have tried to have babies cannot have them; there's no explanation that anybody can see. This might be at least one explanation.

The First Human Cell

After the two pronuclei make a vesica piscis, the male pronucleus continues to permeate the female pronucleus until they are one. At this time it's called a human zygote, the first cell of the human body. So you began as a sphere before you created your familiar human body. Actually, you were a sphere within a sphere.

The next thing you need to know is that the human zygote will not change size during the first nine cell divisions. It's fixed, as is the size of the outer membrane. The human zygote is about 200 times bigger than the average cell in the human body, so big you can actually see it with your naked eye. When it divides into two, each of those two cells are half the original size; and when those two cells divide into four, each cell is a quarter of the original size. The cells keep dividing like this, getting littler and littler, until they've divided eight times and number 512. At that point the average cell size of the human body is reached. When that happens, mitosis continues, and the dividing cells expand beyond the boundaries of the original zona pellucida.

So, first the growth goes into itself, then out beyond itself. When the first growth goes inward, it's as if it's trying to figure out how to do it. Once it figures that out, it goes beyond itself. All life uses this process. I use that same understanding to figure out some of the geometries, which you'll see later.

Progression of Life Forms through the Platonic Solids

To summarize, we start out as a sphere, the ovum. We then move to a tetrahedron at four cells, then on to two interlocked tetrahedrons (a star tetrahedron or a cube) at eight cells. From two cubes at sixteen cells we turn back into a sphere beginning at 32 cells, and from the sphere we become a torus at 512 cells. Planet Earth and its magnetic field is also a torus. All of these forms are sacred shapes that come out of the first informational system of the Fruit of Life, which is based on Metatron's Cube.

We could go on for probably another seven or eight months talking about this subject, showing how more and more and more things are connected to these five shapes-the Platonic solids. But I think you can see exactly what I mean. By the way, modern mathematicians say that the Platonic solids have been known only since civilization began about 6000 years ago, but this is not true. Some put their discovery during the time of Greece. Archaeologists have recently found some perfect models in the earth-perfectly cut in stone-that were found to be 20,000 years old. Those hairy barbarians obviously knew more than we give them credit for.

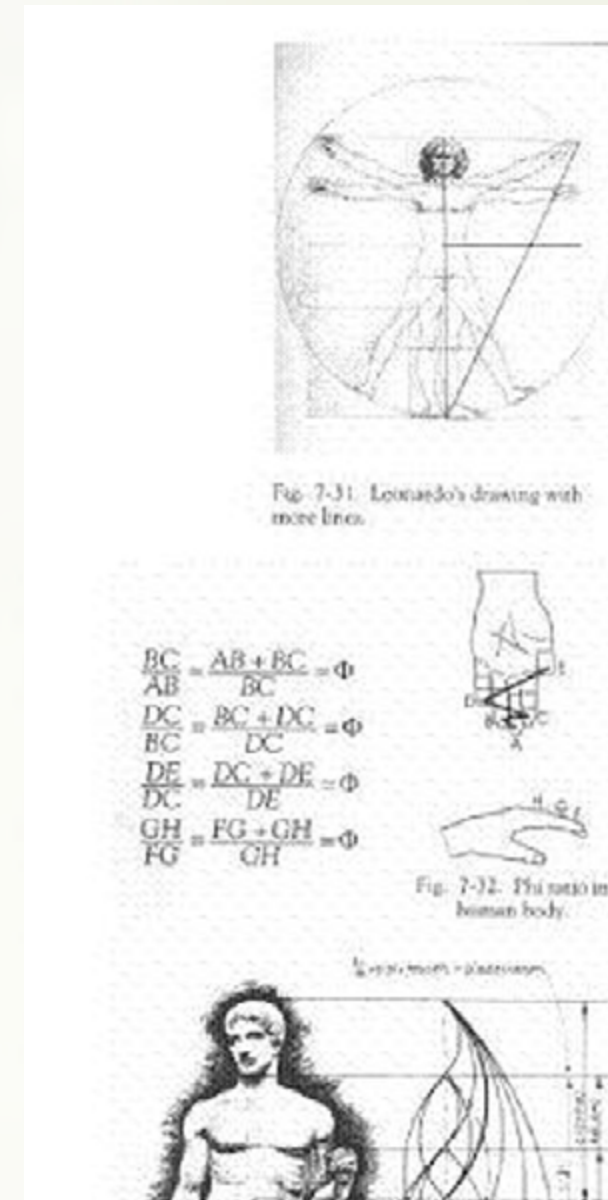
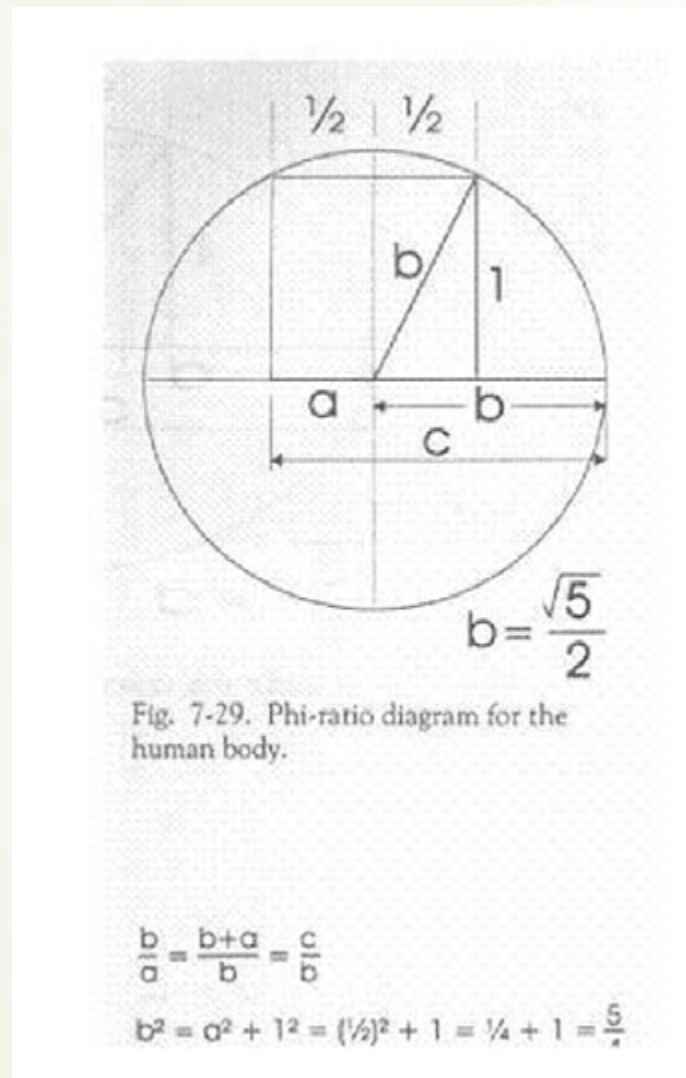

The Phi Ratio

He began to tell me about the phi ratio of 1.618 (rounded here to three decimal points). The phi ratio is a very simple relationship. If you had a rod and you were going to put a mark on it somewhere, only two places would mark the phi ratio, shown as points A and B. There are only two places, depending on which end you're coming from. Shown on the lower drawing, it's a relationship such that if you divide D by C and E by D, the two answers will be the same-1.618 So you divide the longer portion by the shorter portion, and that gives you the ratio 1.618.

When you divide the whole length of E by the next shorter portion, which is D, you'll get the same ratio. I suspect the Masons have lost a great deal of their information. I think that they once had a brilliant knowledge that was very much like the Egyptians', and both of those disciplines have gone downhill.

Studying da Vinci's Canon

This drawing has become probably one of his most famous works. It's perhaps even more important to us than the Mona Lisa or any other famous work of his. This kind of drawing, a standard for something (in this case, a standard for human beings), is called a canon, a human canon.

The first thing that struck me about this drawing is how amazingly we all attune to it. For instance, because there are 30 frames per second that come famous on a video, you could flash this drawing of Leonardo's for just an instant, yet people would immediately recognize it. We know something there is important; perhaps we don't know exactly what it is, but we still retain the image. There is a tremendous amount of information about us in this drawing. But as it turns out, it's not really about us. It's about who we used to be, not about who we are now.

To begin this analysis, notice first that there are lines drawn over the arms and the trunk, across the chest and over the legs and neck. The head is divided into another series of lines. Notice that the feet are drawn at both 90 degrees and 45 degrees-subtle things. Also notice that if you were to stand with your arms straight out and your legs straight down, a square or cube forms around your body, as in Leonardo's drawing. The center of that square is located exactly where the original eight cells are, which is also a square or cube, in the center of your body. Notice the small cube around your original cells and the bigger cube around your adult body. When you are standing with your arms outstretched like Leonardo's man, there is a difference between the height and the width of your square.

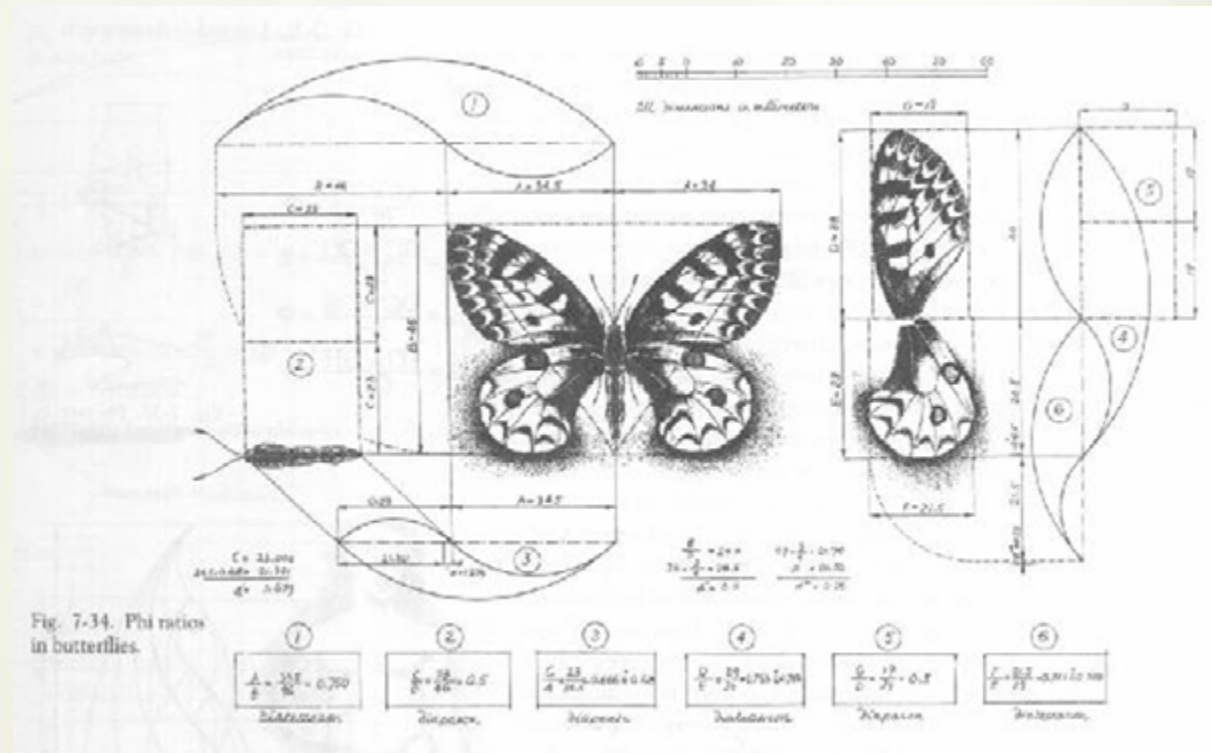

Computers have shown by measuring a hundred people or more that there is one ten- thousandth of an inch difference between the width of your outstretched arms and your height. Though I couldn't understand for a long time why that difference was there, I think I know now. It has to do with the Fibonacci series,

which life is based on. You will see this shortly.

If you put your legs out to the side, like the outer legs on Leonardo's drawing and stretch out your arms like the upper arms, a perfect circle or sphere fits around your body, and its center is located exactly at the navel.

When you do that, the circle and the square exactly touch at the bottom. If you were to move the center of the circle down to the center of the square, the circle and the square would synchronize just like they do in the Mason's drawing and the drawing that shows the warship superimposed over the top of the Great Pyramid. It is a major secret of life.

When you measure almost all the copies of Leonardo's drawings, you find that the circle is really an oval and the square is really a rectangle. It's different in all of them because they've been copied and folded so many times. But in the original, accurate drawing, the hand length from the wrist line to the longest finger equals the distance from the top of the head to the top of the circle when the two centers are aligned; this same length shows up between the navel and the center of the square. So when you bring the two centers together, everything aligns.

Phi Ratios in the Human Body As I was discovering this, I thought, We have these geometrical forms that appear to be outside the body as well as inside it. One of the things the angels said, which really stuck with me, was that the human body is the measuring stick of the universe-that absolutely everything in the universe can be measured and determined from our bodies and from the energy fields around them. Since the phi ratio seemed to be such an important aspect to the Mason, and since he went on and on about it, I wanted to see where it was in the human body.

I discovered it-and of course other people have also discovered it. Realize that in the square is the square around the body as in Leonardo's drawing. And that the line dividing the square in half is the center line of the human body. Also notice that the line b is not only the diagonal of one-half of the square, but is also the radius of the circle. Now, if you are interested in the math, which proves that the phi ratio is found in the geometrical energy fields around the body in at least this one relationship. There are many, many other phi relationships in and around the body.

As you can see, the phi ratio . If you put this into your computer, you will see the transcendental number of phi continue until your computer runs out of memory. I know most of you out there don't care, but I've presented this information for the few. By the way, I'll just throw this out to you: When you're studying sacred geometry, you'll find that diagonals are one of the major keys for extracting information from your forms (in addition to shadows, expanding from two to three dimensions, comparing male to female and so on). It never fails. I believe it was Buddha who asked his disciples to contemplate their navels. Whoever it was, I began to realize as I studied that there was more to the navel than meets the eye. Then I found a medical book, whose authors must have also listened to Buddha, because they did a tremendous amount of research on navels. What the geometries show is that in the ideal, the navel sits at the phi ratio between the top of the head and the bottom of the feet. This is what most books indicate.

The authors found out that when a baby is born, its navel is in the exact geometrical center of the body. Both male and female babies start out this way, and as they grow, the navel starts to move toward the head. It moves up to the phi ratio, then continues upward. Then it comes back down to below the

phi ratio, oscillating during the formative years. I don't know what the ages are, but these movements and locations happen at specific ages. It never actually stops at the perfect phi ratio in either males or females, but if I remember correctly, the male navel ends up slightly above the phi ratio and the female navel just below it. If you average the male and female points, you get the perfect phi ratio. So even though Leonardo's drawing is of a male, it assumes that it is at the phi ratio, but of course in nature it would not be.

Da Vinci figured out that if you draw a square around the body, then a diagonal from foot to extended fingertip, then draw a parallel line: (another one of those parallel lines) from the navel horizontally over to the side of the square, that horizontal line intercepts the diagonal line exactly at its phi ratio as well as that of the vertical line from head to feet. Assuming it's at that perfect point, not slightly above for females or slightly below for males, this means that the human body is divided into phi ratios from top to bottom, which we stated earlier. If these lines were the only places in the human body where the phi ratio is located, it would probably be just an interesting fact. But the truth is, the phi ratio is located in thousands of places throughout the body, and it is not just a coincidence.

Here are some obvious phi-ratio locations in the human body. The length of each bone in the finger has a phi ratio to the next bone, as shown in the lower drawing. That same ratio occurs with all your fingers and toes. This is a somewhat unusual relationship because one finger is longer than the other in what appears to be an arbitrary fashion, but it's not arbitrary-nothing in the human body is. The distances on the fingers marked A to B to C to D to E are all in a phi ratio, as well as the lengths of the phalanges, F to G to H. If you compare the length of the hand to the length of the lower arm bone, it has a phi ratio, just like the length of the lower arm bone compared to the upper arm bone. Or take the length of the foot to the lower leg bone, or that bone to the thigh bone and so on. This phi ratio is found throughout the entire bone structure in all kinds of places and ways. It's usually at places where something bends or changes direction. The body also does it through proportionate sizes of one part to another. If you study this, you will be continually amazed. You make a curve so that you can see how one curve is linked with another, and you can see all the cascading phi ratios of the human body.

This is from *The Power of Limits* by Gyorgy Doczi. I highly recommend this book. Notice that on this male he drew the line for the navel slightly above where the actual phi ratio is located. He knew about that, and very few people I have read understand it. I want to talk about this Greek statue. The Greeks were well aware of this understanding of phi ratios. So were the Egyptians and many, many other people in ancient times. When they created a piece of art like this, they were actually using both sides of the brain simultaneously. They were using their left brain to very carefully measure everything-I mean really carefully, not kind of or sort of. They were measuring to make sure that everything was exactly mathematically correct according to the phi proportion. To be as creative as they wanted, they were also using their right brain. They could put any expression on the face and have the statue hold anything or do anything they wanted. The Greeks combined the left and right brain. When the Romans came in and took over Greece, the Romans knew absolutely nothing about sacred geometry. They saw the Greeks' incredible art and tried to duplicate it, but if you compare Greek art to Roman art after they conquered Greece, Roman art looks like it was done by amateurs. Even though Roman artists were really good at what they did, they just didn't know they were supposed to measure everything-that there had to be this kind of perfection for the body to look real.

The Phi Ratio in All Known Organic Structures

Phi-ratio mathematics goes not only through human life, but through the entire spectrum of all known organic structure. You can find this in butterflies or dragonflies, where each little tail section is proportioned to the phi ratio. The lengths of the sections of the dragonfly form phi ratios. This illustrator was focusing on one thing, but you can also look where every little bend is in the legs, the length and width of the wings, the size of the head compared to its width and length-every-thing. You can go on and on and on, and you'll keep finding the phi ratio everywhere you look. Look at this frog skeleton and see how every single bone is in phi-ratio patterns, just like in the human body. Fish, I think, are really incredible, because fish don't look like they have any phi-ratio stuff going on-and there are so many different kinds.

But when you analyze them, the phi ratio is there as well. The other universal measurement you'll find, one I talked about before, is 7.23 centimeters, the wavelength of the universe. You'll find this wavelength scattered through the body, such as the distance between your eyes; but the phi ratio occurs more often than any other. Once a measurement of any species has been determined, then every other measurement in that species follows in the phi ratio proportion. To put it another way, there are only certain possibilities in human structure, and once the size of one part of the body is determined, that determines the size of the next, and on and on. Soon I'll show you the Egyptian building that Lucy de Lubicz reconstructed just by measuring one little piece of rubble. This is how she did it: Once she knew the size of the first piece, she knew that every shape after that would relate to it in phi ratios.

The phi proportions are built into this Japanese pagoda architecture. This illustrates another point about creativity that I want to make. When they designed and built this structure, they carefully measured every single distance to match the various lines shown, and they carefully measured where to put each board-right down to that little ball on the very top, so that it could correspond with and form these relationships we have been studying. I'm sure if someone ever checks, they'll find that the size of the doors, the windows and probably every small detail are all based on phi proportions or other sacred geometry. Other classical architecture around the world used the same principles. The Greek Parthenon looks really different from this Japanese structure, but the Partheon embodies the same mathematics. And the Great Pyramid looks very different from either of those two buildings, but it also embodies the same mathematics-only a lot more. What I'm saying is, your left brain can understand and use these mathematics, and it doesn't hinder creativity at all. It can even enhance it.

Golden Mean Rectangles and Spirals around the Body

Another sacred form we have in life is the spiral. You may wonder where it came from. We're living in a spiral-the galaxy, which has spiraling arms. You're using spirals to listen to the sounds around you because the little apparatus in your ears is in a spiral form. There are spirals all over nature. The more you look, the more you find. Spirals are found in pine cones, sunflowers, a few animal horns, deer antlers, seashells, daisies and lots of plants. If you put your open hand vertically in front of you, thumb toward your face, notice the movement as you roll your fingers into a fist, starting with your little finger. They trace out a Fibonacci spiral. This is a very special spiral, as you will see. Where do spirals come from? They have to come from somewhere, and they have to be generated out of the dynamics of the original

system, the Flower of Life, if what we believe is true. Well, all you have to do is go back to the human body-to the same pattern we came up with for the phi ratio. If you simply take the diagonal line, lay it down flat, then complete the rectangle formed with that new extension-you have a Golden Mean rectangle, the source of the Golden Mean spiral. The outer rectangle of this drawing is called a Golden Mean rectangle, the same as above.

To get another Golden Mean rectangle, all you have to do is measure the rectangle's shorter edge (side A) and plot that distance along the longer side (side B), which makes a square (with equal sides; $A = C$). The area that's left over (D) is another Golden Mean rectangle. Then you can take the shorter edge again and plot that distance along the longer edge to make another square, and what's left over is still another Golden Mean rectangle. This can continue forever. Notice that each newly formed rectangle is turned 90 degrees. If you run diagonals across each rectangle, their crossing locates the exact center of the spiral they form. You can see how the diagonals become a key for more information: Line F has a Golden Mean ratio to line E, continuing inward. We can say that F is to E what G is to F and H is to G and I is to H and so on. There are other kinds of spirals, but the Golden Mean spiral is paramount in creation.

Male and Female Spirals

There are two kinds of energies that move through Golden Mean rectangles. One energy is the diagonals that cross the squares, moving at 90-degree turns, shown in black. That's the male energy. The female energy is the line that keeps curving in toward the center, shown in gray. So you have a female Golden Mean logarithmic spiral, along with a male spiral that uses straight lines with 90-degree turns at the phi ratio. In much of the work I will show you, we'll be looking only at the male aspect, but you must remember that the female aspect is always there.

Some books say that if you draw a horizontal line through the navel in da Vinci's man, what's left over in the lower portion is a Golden Mean rectangle; and that if you draw a line from the top corner of the large square to the middle point at his feet (the center of the opposite side of the square), that semi-diagonal will pass through the exact center of a Golden Mean spiral as shown in the figure.

You can create a spiral if you draw in the consecutively smaller Golden Mean rectangles. But something else is actually happening that is important to understand if one really wants to know about Mother Nature. In fact, I'm convinced that there are no Golden Mean rectangles or spirals in existence unless they're synthetically made. Nature does not use Golden Mean rectangles or spirals-it doesn't know how. The reason nature doesn't know how is because a Golden Mean spiral will literally go inward forever--maybe not with a pencil and paper, but technically it will go on forever and ever. It will also go outward forever too, because you can take the longest line of any Golden Mean rectangle, make a square to get a larger Golden Mean rectangle and continue to do this forever. So a Golden Mean rectangle has no beginning and no end. It will go inward and outward forever.

This is a problem for Mother Nature. Life doesn't know how to deal with something that has no beginning and no end. We can sort of deal with something that has no end, but if you think about it, it's difficult to think of something having no beginning. Just try to get that in your mind-something that has no beginning. This is hard for us because we are geometric beings, and geometry has centers, beginnings.

before

after

SCIO FOR PAIN

IT IS A SCIENTIFIC FACT THAT A LOW LEVEL VOLTAMMETRIC PULSE CAN INHIBIT PAIN SIGNALS. THE SCIO WILL LET THE PATIENT'S BODY ELECTRIC AUTOFOCUS A HARMONIC PULSE TO MAXIMIZE THIS EFFECT. THIS IS CALLED

MICRO-CURRENT TRANSCUTANEOUS ELECTRO-NEURAL STIMULATION

AND CAN HELP YOU TO REDUCE PAIN WHILE HELPING YOU FIND THE CAUSE...

If you need more information on the SCIO and purchase details please get in touch with us

Maitreya Kft.
tel: +3613036043
web: www.qxsubspace.com
e-mail: info@qxsubspace.com

Since life doesn't know how to deal with this, it has found a way to cheat. It has found another spiral to create with. Life figured out a system of mathematics that approximates this so well that you can hardly tell the difference. The books say that this spiral on Leonardo's drawing in Figure 7-40 is a Golden Mean spiral, which I say can't be true. Also, there is not just one little spiral here; there are eight spirals rotating around the body one for each Golden Mean rectangle, connected to the eight possible semi-diagonals around the human body. This drawing shows the eight that intersect the human body.

Figure 7-42 shows the eight spirals with their eight centers located around the center of the body, in the same pattern and with the same center as the original eight cells inside the body-right? Leonardo drew these little lines that make a grid over and around the body: There are four squares in the center (A, B, C and V) and eight squares surrounding them (E through L). So we have eight places around the body and a central pattern of four squares in the middle, centered exactly around the original eight cells. Life is amazing, is it not? When I noticed this about Leonardo's drawing, I figured there must be something important about this relationship. But when I realized that there's no such thing as a Golden Mean rectangle or spiral in nature, I began to suspect that these spirals were probably something slightly different.

And that's what they turned out to be—slightly different. It turns out that these spirals are Fibonacci in nature, which we will explore in the next chapter. Understanding the difference between the Golden Mean and Fibonacci spirals may seem simple and unimportant, until the bigger picture of nature unfolds to reveal something astonishing about this relationship. No one can ever understand why the 83,000 sacred sites on the Earth were built or what their purpose was without knowing this difference.

Reconciling the Fibonacci-Binary Polarity The Fibonacci Sequence and Spiral

In order to understand why those eight spirals around da Vinci's canon are not Golden Mean spirals and to find out what they are, we have to go to another person—not Leonardo da Vinci, but Leonardo Fibonacci. Fibonacci preceded da Vinci by over 250 years. From what I've read about him, he was a monastic, often in a meditative state. He loved to walk through wooded forests and meditate as he was walking. But evidently his left brain was simultaneously active, because he started to notice that plants and flowers had number associations. Flower petals and leaf and seed patterns correspond to definite numbers, and the flowers on this list are the ones I think he saw, if I've got it right. He noticed that lilies and irises have three petals and that buttercups, larkspurs and columbines have five. Some delphiniums have 8 petals, corn marigolds have 13 and some asters have 21. Daisies almost always have either 34, 55 or 89 petals. He began to see these same numbers over and over again throughout nature. Fibonacci noticed that when the sneezewort plant first came out of the ground, it grew only one leaf, just one little leaf. As it grew taller, farther up on its stem it grew one more leaf; then a little bit farther it grew two leaves, then three, then five, then eight; then it had thirteen flowers. He probably said, "Gee, those are the same numbers I keep seeing in the petals of other flowers—3, 5, 8, 13." Eventually this sequence of 1, 1, 2, 3, 5, 8, 13, 21, 34, 55, 89 and so on became known as the Fibonacci sequence. If you are given any three consecutive numbers in this sequence, you can recognize the pattern: you simply add two consecutive numbers to get the next number. See how it works? This is a very special sequence. It's crucial in life.

Why is it important? This is perhaps my interpretation of why, but I'll do my best to show you.

The stamen inside has five terminating buds, and the direction of those two geometric forms are reversed to each other, one set pointing up and one pointing down. When most people look at this flower, they don't think, "Let's see, it has five petals." They simply look at it, notice it's beautiful, smell it and experience it from their right brain. They're not thinking about the geometry or mathematics going on in the other side of the brain. Life's Solution to the Infinite Golden Mean (Phi) Spiral Remember that I said how the Golden Mean spiral has no beginning and no end, and that life has a hard time with that? It can cope with no end, but it has a difficult time working something~ that has no beginning. I have a really hard time doing it, and I think we all wrestle with that situation. What nature did was create the Fibonacci sequence to get around the problem. It's like God said, "Okay, go out there and create with the Golden Mean spiral," and we said, "We don't know how." So we made up something that is not the Golden Mean spiral, but it rapidly comes so close that you can hardly tell the difference. For example, the phi ratio associated with the Golden Mean is approximated by 1.6180339.

Look what happens when you divide each number in the Fibonacci sequence into the next higher number. Here's the sequence in the left column: 1, 2, 3, 5, 8, 13, 21, 34, 55, 89. In the second column I've shifted the sequence by one so we can divide the number in the first column by the number in the second column (see column 3). Notice what happens when you divide a column-two number into the one in column one. When we divide 1 into 1, we get 1.0. Now, 1.0 is a lot less than the phi ratio. But when we go to the next line and divide 1 into 2, we get 2, which is greater than phi, but closer than I is. When we divide 2 into 3 we get 1.5, which is a lot closer to phi than either of the previous two answers, but it's under. Three into 5 is 1.6666, which is over, but a lot closer. Five into 8 is 1.60, and it's under. Eight into 13 is 1.625, which is over. Thirteen into 21 is 1.615, under. Twenty-one into 34 is 1.619, over. Thirty-four into 55, 1.617, under. Fifty-five into 89, 1.6181, over. The next one goes under, then over, each time getting closer and closer to the actual phi ratio. This is called asymptotically reaching a limit. It can never ever reach the actual number, but practically speaking, you wouldn't be able to tell the difference after a few divisions. The light gray squares are the four central squares of the human body where the original eight cells are located. The eight dark gray squares around these central squares are where the spirals begin. Rather than having them spiraling in forever and ever, we're going to do something different—because this is what life does, I believe.

I'm going to use one of the outer squares as my starting point, and this will be true for all eight. I'm choosing one of them as an example. Using a diagonal across just one of the tiny background squares as our measure, we'll call this diagonal line one unit. Then we move according to the Fibonacci numbers: 1, 1, 2, 3, 5, 8, 13, 21, 34, 89, with a 90-degree turn after each number. In our first step we go one length, then turn 90 degrees and go one again. Then we turn 90 degrees and go two lengths, turn another 90 degrees and go three lengths. Between each step we take a 90-degree turn. The next step is 5 units long, then 8. So we have 1, 1, 2, 3, 5, 8, 13. Then we diagonally cross 21 squares, then 34. Then 55, then 89. As we do this, the spiral unfolds and gets closer and closer to phi, the Golden Mean spiral, until very rapidly there's no way to tell the difference in life, at least visually. Comparing the two spirals must have been a very important feature if one studied life, because the ancient Egyptians displayed both the Fibonacci and the Golden Mean spirals at the Great Pyramid. Even though the spirals have two different origins, by the time they get out to steps 55 and 89, the two lines are practically identical. When people who

studied Egypt saw the three pyramids lined up on the spiral, they thought it was the Golden Mean, not the Fibonacci spiral. The 11 they came back and found one of the holes. Several years later they realized that just a little ways away, maybe a hundred yards or so, was another marker. They hadn't realized there were two spirals. I don't know whether the people working with this understand its significance even yet.

Spirals in Nature

Here is sacred geometry in nature. It's a nautilus shell cut in half. It's an unwritten rule that every good sacred geometry book has to have a nautilus shell in it. Many books say this is a Golden Mean spiral, but it's not—it's a Fibonacci spiral.

You can see the perfection of the arms of the spiral, but if you look at the center or beginning, it doesn't look so perfect. You can't really see this detail here. I suggest that you look at a real one. This innermost end actually hits the other side and bends, because its value is 1.0, which is a long way from phi. The second and third ones bend also, but not as much because they are coming closer to phi. Then they start fitting better and better, until you see this perfectly graceful form developing. You could think that the little nautilus made a mistake in the beginning; it looks like he didn't know what he was doing. But he's doing it perfectly, it's not a mistake. He's simply following exactly the mathematics of the Fibonacci sequence. On a pine cone you see a double spiral, one going one way and one going the other. If you were to count the number of spirals rotating one direction and those going the other direction, you'd find that they're always two consecutive Fibonacci numbers. There are perhaps 8 going one way and 13 the other, or 13 going one way and 21 the other. The many other double-spiral patterns found throughout nature correspond to this in all cases that I know. For instance, the sunflower spirals are always related to the Fibonacci sequence. Figure 8-10 shows the difference between the two.

The Golden Mean spiral is the ideal. It's like God, the Source. As you can see, the top four squares on both drawings are the same size. The difference is in the areas where they originate (the bottom sections of the two diagrams). The bottom of the Fibonacci spiral has an area half the size (0.5) of the area above; the Golden Mean spiral has an area 0.618 the size of the area above. The Fibonacci spiral shown at near right is constructed using six equal squares, whereas the Golden Mean spiral starts deeper inside (actually, it never starts—it has been going on forever like God). Even though the originating point is different, they very quickly approximate each other.

Another example: Many books state that the King's Chamber is a Golden Mean rectangle, but it's not. It's also tied to Fibonacci.

Fibonacci Spirals around Humans

When we draw a 64-square grid and incorporate this spiral pattern, we get Superimposing da Vinci's canon over this 8-by-8 grid, the eight squares (shaded) seem to have a unique attribute. There are four possible ways to move a Fibonacci spiral out of one of the four double squares. Let's use the upper double square as an example. One way to start is from the upper right corner, as shown by the darker line. It crosses one square (1), turns right to cross one more square (1), turns right again to cross two squares

(2)—interestingly enough, it reaches the top of the grid at this point. Continuing to turn right, it crosses 3 (the next number in the sequence)—and, son-of-a-gun, it has now reached the right side of the grid! The next number is 5, which takes the line to the bottom of the grid. The following number, 8, takes the line across three squares before it leaves the grid. There's a perfect reflective quality as this spiral moves out from the beginning square. Another way you could start in this double square is from the lower right corner, as shown by the lighter line (this forms a little pyramid in the top two squares).

In this case your 90-degree turns will be to the left. So you cross one square (1), then one again (1), then 2—this time passing through the center four squares of the grid (where the original eight cells reside). After that, it goes left again to cross 3 squares, the line touches the right side of the grid. The next number, 5, will leave the grid after crossing two squares. It's a perfect synchronicity of movement. Whenever you see this kind of perfection, you know you're almost surely hitting on really basic geometries.

All this is crucial to understand, if you care to know, how the Egyptians achieved resurrection. They were doing it scientifically, you might say. They were using science to create a synthetic state of awareness that would lead to immortality. We're not going to achieve our awareness synthetically; we're going to do it naturally, but you might find it useful to understand how an ancient civilization was attempting to achieve this.

The Human Grid and Zero-Point Technology

This basic sacred geometry of a 64-square grid around humans is becoming understood in science. In fact, there's an entirely new science happening around it, though it's having a hard time getting out because of politics. This new science is called zero-point technology. This grid is, I believe, the geometry of UPDATE: Since the time of Tesla, governments have not allowed the knowledge of zero point to come forth. Why? Tesla wanted to give free, unlimited energy to the world, which he knew would come from zero-point technology. But J.P. Morgan, who owned many copper mines, did not want electricity to be free. Instead, he wanted to force electricity to pass through copper wires so he could meter it, charge the public and make money. Tesla was stopped, and the world has been controlled ever since.

Since that time in the 1940s, any person who researched zero-point technology and talked publicly about it was killed or disappeared—until just recently. In 1997 a video company called Lightworks secretly brought together a few of these scientists and filmed their works. They gave the history of what had happened since the 1940s and showed clear working models of the inventions. They showed machines that, once running, give off more electricity than it takes to run them. They showed batteries zero-point technology, though most scientists see it in a different way.

Most people involved in zero-point technology think of it in terms of waveforms or energy. They talk about the five places in a waveform, as shown here. Or they think of zero point as the amount of energy that matter has when (and if) it reaches zero degrees Kelvin, or absolute zero. To me, both of these ways are valid, but the way based on sacred geometry will eventually become the cornerstone of this new science because it is so fundamental. These points associated with the waveform are also related to breathing. These points are where the zero point is accessed. They are like doorways into another world. Yogic pranayama is usually talked about in terms of two or three places (depending on whether

you count the beginning of the next cycle), which are between the inbreath and the outbreath. That's also zero-point technology if you focus it on human breathing. This new zero-point understanding has a geometry behind it, and that geometry is around the human body. The human body is always the measuring stick of creation.

Male- and Female-Originating Spirals

To begin with we must understand that there are two kinds of spirals, depending on whether they are straight lines (male) or curved lines (female). We talked about this before. However, now we are going to introduce a new concept. The originating point of the spiral in this geometric pattern will further determine if it is male or female in a different way. In a double square there are four corners where a spiral can originate. top right, bottom left and bottom right. The two top positions produce male spirals, the two bottom positions, female spirals. The male spiral lines never pass through the center four squares; the female lines always do.

To make it clear, we will give an example. If the spiral begins at the top right point, it will be a male spiral relative to this geometrical pattern. In addition, the curved aspect of this male spiral would be female, and the straight-line aspect would be male. Every polarity always has another polarity within it, and within that new polarity there is always still another polarity. This division process will continue theoretically forever. We see the female spirals around the human body, which originate at the bottom, or closest points to center. Here we show primarily the male (straight-line) aspect of these female spirals. The female (curved) aspect of only two female spirals are shown (not all eight), which form a heart. Notice the pattern they create. One heart faces one way, and after it has been extended 180 degrees, a bigger heart faces the other way. Every one of these curved female lines passes through zero point at the exact center of the human body.

This zero point is the creation point, or what we would call the womb. It is for this reason that females have the womb in their bodies and males do not. Males never pass through zero point.

Later you'll see these heart-shaped relationships tied to many other natural phenomena such as light, eyes and emotions, to mention a few, so keep them in mind. Now, with that understanding we're going to look at another sequence. There are thousands of mathematical sequences; I suppose on one level you could even say an infinite number. But in useful terms, there are many. A sequence can simply be 1, 2, 3, 4, 5, 6, 7, 8. In every one of the thousands and thousands of sequences known to man, three numbers are required to identify the pattern, the whole sequence-with the exception of the Golden Mean logarithmic sequence, in which case you need only two. This implies that it is probably the source of all other sequences.

According to my guidance, two sequences besides the Golden Mean are of major importance to nature and life. They are the Fibonacci sequence, which we just looked at, and the binary sequence we are about to look at. Here we will see the Fibonacci as female and the binary as male. They are really more than just female and male; they act more as mother and father.

They are both primary, coming straight from the Golden Mean, just as the two primary colors that come from white light are red and blue.

Desiré

APOLLO AND THE U F O



The true story of how Bill worked on the Apollo mission and helped the astronauts back on the 13 mission. The story continues to prove the existence of UFOs.



Special appearance from the Lizard Alien

Keith Critchlow's Triangles and Their Musical Significance

Another image on this drawing is an equilateral triangle with the horizontal line running straight through the middle from 0 to 180 degrees. This is the side view of the tetrahedron. Now, you might not think that's important, and I probably would have never picked up on it, but another person did-Keith Critchlow. We don't know what he was thinking or how he arrived at this. He didn't know what you know right now when he did it. (He may know it now after he's seen this work, but he didn't when he wrote his book.) Critchlow drew an equilateral triangle with a line through the middle; then he measured to the middle of the center line (see black dot) and drew a line down to the corner and up to the top edge and then vertically down to the center line, as shown. Who knows why?

Where that first diagonal line crossed the center line, he then drew a vertical line to the upper edge, then down to the same lower corner. Using the point where it crossed the center line, he repeated what he had done before, then did it once more to the left. You could keep going in both directions from your first line. By drawing this funny little form, he discovered something of great importance. He says, "Continuing in this way" (in that pattern of construction), "each successive proportion will be the harmonic mean between the previous proportion and the total length, and all these proportions will be musically significant, $1/2$ being the octave, $2/3$ being the fifth, $4/5$ being the major third, $8/9$ being the major tone [step] and $16/17$ being the half tone [half step]. In other words, he's comparing the measurement of these lines to musical tones.

He then tried measuring it in a different way, starting at a different point of the center line, at three-fourths (see black dot), and found that the measurements were $1/7$, $1/4$, $2/5$, $4/7$, $8/11$ and $16/19$ -and all these numbers are musically significant.

This is very, very interesting. It means that the harmonics of music are somehow related to the proportions of this central line moving through a tetrahedron. But he had to measure first to begin, and if you have to use a measuring stick, you're not at the core of sacred geometry; something's missing. If you're right in sacred geometry, you never have to use anything to measure. The measuring apparatus is built in so that you can calculate everything without having any kind of calculus or ruler or anything else.

It's always built right into the system. I experimented with his drawings and discovered that if I put the polar graph behind his pattern, I could reproduce his first pattern, which showed the octave-the halfway mark-without any measuring.

All I had to do was draw over a line that was already there from the lowest apex of the triangle through the center of the sphere to the opposite side of the triangle; when I dropped the line straight down, it divided the center line exactly in half, which was the octave point Critchlow had found. Then the other three lines could automatically be drawn. I then discovered that the outermost circle of the polar graph, which circumscribes the equilateral triangle, was also harmonic to the central line: the vertical line at 60 degrees (line A) exactly overlies line B. There is a correspondence between the male (straight lines) and the female (curved lines) components inside and outside the triangle, and these proportions were all musically significant. And I didn't have to measure anything!

We have now taken this light-years beyond the above. A research team has found that you can draw these lines not only from the center, but from any of the nodal points inside the upper half of the triangle, and you will come up with all known harmonics in existence. In other words, if you draw a line from any of the points where the straight and curved lines cross from 0 to 120 degrees, then down to the corner of the primary triangle and start making your patterns, you'll come up with all the harmonic systems, not only the Western keyboard, but the Eastern systems as well-in fact, all known harmonic systems and many unknown ones that have never been used.

People who have done this research now believe that all the laws of physics can be derived from musical harmonics, now that the full system of harmonics has been revealed. I personally believe that the harmonics of music and the laws of physics are interrelated, and we now believe we've proven this mathematically and geometrically, though it is not fully shown here.

I was very excited at the time I was gathering this information, because the implications are incredible. It means that the harmonics of music are located inside a tetrahedron, and that these harmonics are now determinable. Since then we've discovered another geometric pattern behind the one shown in this illustration that reveals all the keys, and it has opened up all the inner meanings of what Egypt was about. The Egyptians reduced their entire philosophy to the square roots of 2, 3, and 5 and the 3-4-5 triangle. Many people have given explanations for it, but there's another explanation hidden behind the geometry of the tetrahedron. That idea probably went over almost everybody's head, including mine, in a way. But it's there and we're working on it now.



Maps for the Left Brain and Their Emotional Component

There's one more simple teaching I would like to give here. Drawing the tetrahedron over the polar graph geometrically represents the harmonics of music. That drawing and the information I've given you on this subject comes into your understanding through your left brain. But do you remember how we went through those visualizations, where I was saying that every line on a page is not a line on a page, but a map of how spirit moves through the Void? So these drawings are maps-for the left brain. But there's another component that's equally important to understand:

Besides being a map of how Spirit moves in the Void, the lines on any sacred-geometry drawing also represent something else. For every line in sacred geometry, there is always an associated emotional and experiential aspect. There is not only a mental component, but an emotional component that can also be experienced. A sacred-geometry drawing can enter human consciousness through the left brain, but there is a way that it can also enter experientially through the right brain. Sometimes this emotional/experiential component is not obvious.

What does this mean? Let's use music as an example. Music can come into human experience as sound and be heard and felt inside us, or it can be understood by the left brain as proportion and mathematics. As you study sacred geometry, remember that both sides of the brain use the same information differently.

Form and the sacred geometry associated with it are the source, but the way this information enters the human experience is different. It's usually a lot easier to take in information experientially through the right brain than through the logical left brain, but they're equivalent. It's hard to see that they're equivalent, but they are. Throughout all this geometry, as you look at these triangles and squares around the body and the relating spheres and shapes, some kind of experience is associated with each geometry. Maybe you don't know what the particular experience is. It might take a whole lifetime to figure out what it relates to, but it's my belief that there is always an experiential aspect associated with every sacred geometrical form.

AFTERWORD

It is now becoming clear that geometry-and thereby proportion-is the hidden law of nature. It is even more fundamental than mathematics, for all the laws of nature can be derived directly from sacred geometry. In the second part of this work we will show you more of nature's secrets.

We believe it will begin to change the way you see the world you live in. It will become clear that your body is the measuring stick or the holographic image of the universe, and that you, the spirit, play a more important role in life than society has taught us.

Finally (and this will be paramount in this work), you will begin to see how the geometries are located in the ElectroMagnetic fields around your body that are about 55 feet in diameter. Remembering these fields is the beginning of human awakening, like a baby bird breaking into the light and out of the darkness inside its eggshell. The sacred and holy human lightbody, called the Mer-Ka-Ba by the ancients, becomes a reality. This Mer-Ka-Ba is the "wheels within wheels" of Ezekiel in the Bible. The pathway home through the stars becomes evident as the blueprint of creation emerges.

Deciphering the Hebrew Bible Code

Update: There is a book called *The Bible Code* by Michael Drosnin. This book, once it is known by the public, will have a tremendous effect on consciousness and will greatly break down the sense of separation from God. Dr. Eli Rips, an Israeli mathematician, has discovered that there is a sophisticated computer code in the Hebrew Bible. It has been checked by Yale and Harvard and even the Pentagon, all of whom have further proved it is true. This is a scientific discovery, not just someone's fantasy. What they have found is that (probably) all persons and events that occur in time and space have been written in the Bible thousands of years ago, which clearly shows that the future is known. Detailed information such as the date and place you were born and the date and place that you will die (in the future) as well as the primary achievements of your life are already written in the Bible. This may sound outrageous, but it is true. The odds have been calculated to be at least one in a million. Read the book for yourself. Is this the "secret book" that the Bible says is hidden and will not be opened until the "end of time"? According to the Mayan calendar, we are entering "the end of time."

Hebrew to mathematics in diagram

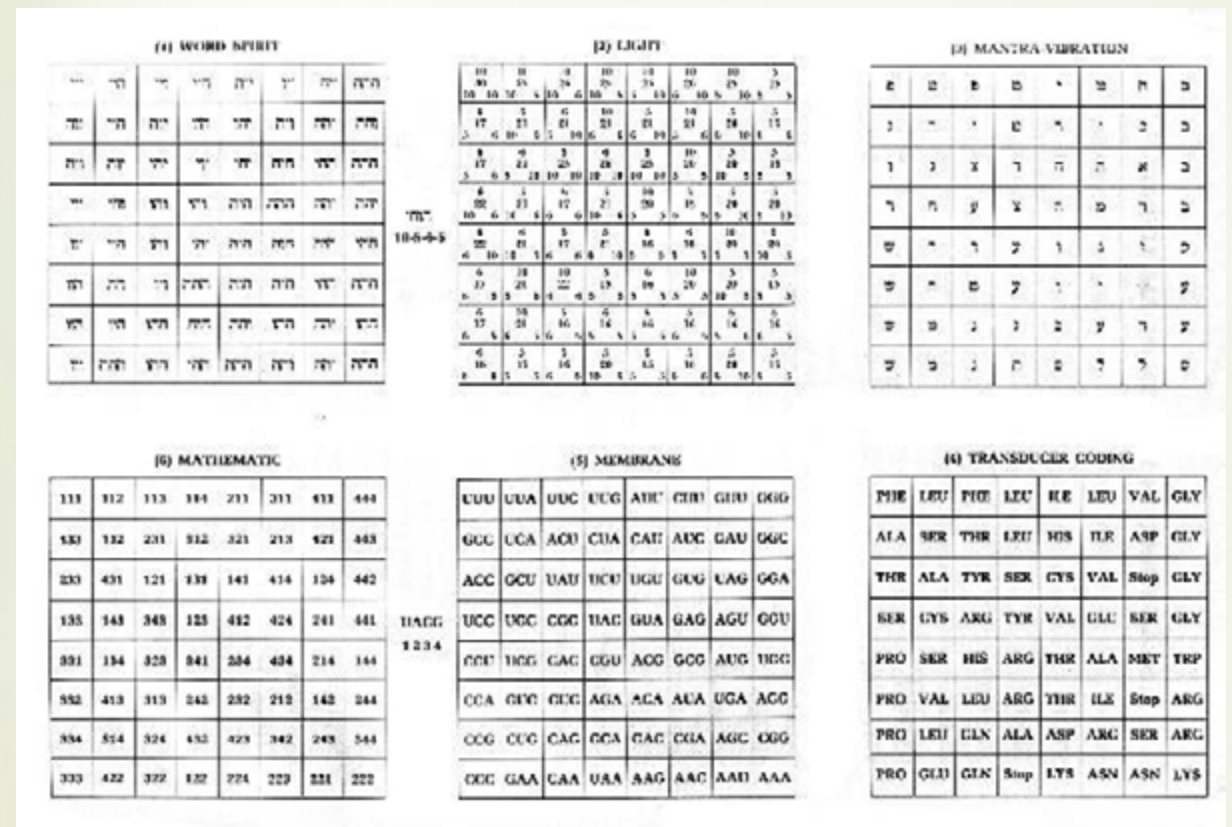

A Sanskrit Poem and Pi

Let's look at something totally different now to suggest that the ancient beings of this world were perhaps more evolved than we give them credit for. We can make a phonetic translation of a Sanskrit poem. It was shown in an article published in *Clarion Call* magazine, in the early eighties, I believe. The

English translation is shown below the Sanscrit. Over many years researchers have discovered that each one of these Sanskrit sounds corresponds to a numerical value. It took them a long time to figure this out. Samples of all the various sounds that are possible in Sanskrit. Each sound has a numerical value from zero to nine, and some syllables have two number values. For instance, ka, a primary sound, translates as spirit and corresponds to either zero or one, depending on its usage, I assume.

When researchers took these different sound values and applied them to this particular poem, a mathematical figure came up that is extremely significant: 0.3141592653589 . . . continuing out to thirty-two digits. This is the exact number of pi divided by ten carried to thirty-two digits! No one has ever figured out how to calculate for the decimal point, which is why this is pi over ten. If you move the decimal point one digit to the right, then it would be 3.1415 etc., the diameter of a circle divided into its circumference. Well, they might have known about the diameter of a circle divided into its circumference, but in our culture's understanding of who these ancients were, there is no possibility that they could have calculated it with that kind of accuracy. Yet here is undeniable evidence.

Pi the basic relationship of a circle to its diameter, square root of 2, 3 etc are irrational numbers, Feinbaums fractal system number, Fibonacci and many more are examples that our universe has a powerful female or unknowable component. We can not totally know. The development of right brain and female systems is a trend of future technology. When Prof Nelson took both forms, a champion for the right brain tech stepped forward. Armed with the left and right brain intellect some one can now explain the right to the left, and bridge the gap.

Christ as the Word made Flesh

The existence of Jesus is an undeniable historical fact.. Certain aspects of his constitution are debatable. But it is indisputable that he was Jewish, a learned man in the books of the Temple, He taught in synagogues, He was an expert in the Torah. He would be acutely aware of the power of the words of the worship of Jehovah. The exact pronunciation of God's name is forbidden in Jewish law, but the power of certain words is an exact science to Jesus. As he once said "I have not come to change the law, but to fulfill it". I have to wonder why certain present day Christians have trouble with these undeniable facts.

Many years before a long distant relative of Jesus, Solomon was known as the most intelligent man and king of Israel. Solomon was fascinated by the other dimensions, and the vibratory sounds which could access those levels. The entities on the other planes of existence are not always pure just because they are other worldly. Quite the opposite, there are good and bad forces every where. This is why there is a warning in Leviticus. Beware of the diviner. There is potential danger in divination of any kind. Channeling, muscle testing, radionics, etc must take extreme precautions. Solomon dedicated the last 25 years of his life to cataloging the angles, demons, and other entities on the other planes. He devised a fool proof protection ritual as well.

This is a must in subspace therapy. it is the heart of the QXCI system. Jesus would have been acutely aware of this ritual. This secret guarded ritual was taught to me years ago by a Hasidic scholar. I also found an ancient manuscript of the Hammer of Solomon. The teachings of Jesus have fulfilled this art and consummate the protection and investigation process. Using the protections from Muslim, Buddha,

Hindu, Sanscrit, Shinto, Taoist, and many others, is also essential. This and other sources have lead me to develop the protection for the QXCI. The ancient text of the Book of Enoch is vital and I can now include several excerpts from this text. As you read you can feel the power of the words.

BOOK OF ENOCH (excerpts)

We live in a Many and One Universe

The creative mind as the center of this universe is known as

"Lord", "King", and "Redeemer".

The creations which survive are creations which desire that the specie gather Life and Light into the "Image and Similitude" of the

"Higher Evolution" which is the "Living Universe".

The keys to the living biophysical and astrophysical universe are the

living "Light Pyramids of Live" existing within every structure within every field of creation.

The key to our astrophysical time zone is the "Three and One" alignment of consciousness forces in the Great Pyramid with the "Twelve and One" energies of time warp pyramids centered and controlled by the "Many and One" Throne Energies of Orionis and the Pleiades.

Our universe was created out of the "Light Synthesis" of the next universe, the Pleiades, the cradle and the throne of our consciousness. The key name given to enter into the presence of the Throne "Light" Pyramid of the next Universe is ~METATRON~. The key to the Pyramid-Sphinx in the middle of earth is the "HIGH FREQUENCY SOLAR VEHICLE" given in the symbol of the Lion-Sun and in the symbolic structure of the space-time pyramid which gives to all levels of evolution in our zone the mathematical-astronomical keys to the surrounding "HIGHER EVOLUTION". The anti-universe is composed of star field energies revealed on the Black Cube in Mecca which shows the function and destruction of three-dimensional universes.

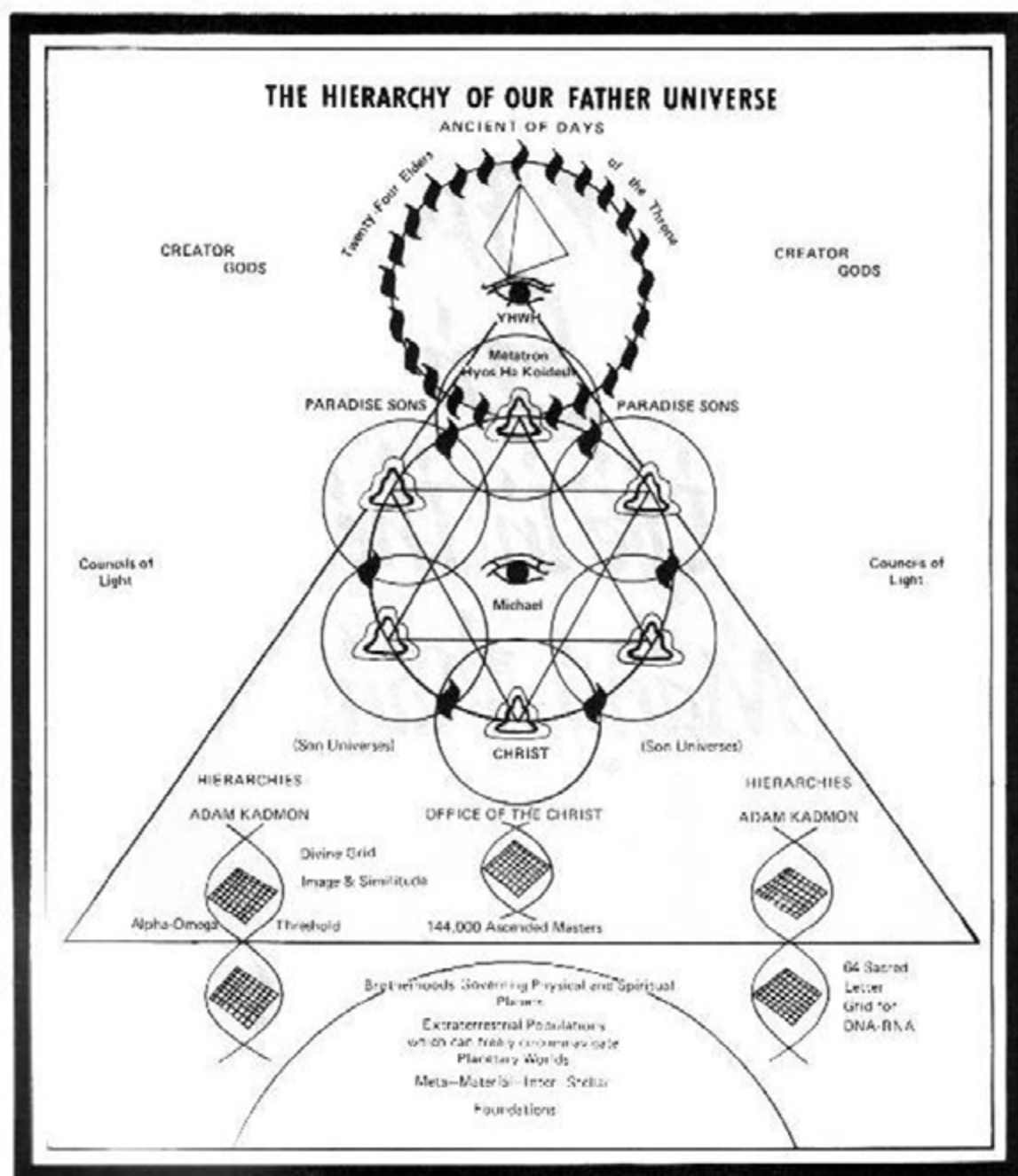

The key languages connecting mind-time worps to inter-connecting civilization and manifestations of "HIGHER EVOLUTION" in our timezone are Egyptian-Hebrew-Sanskrit-Tibetan-Chinese.

The Throne-Energies are the "Sacred Names" that can take you into the Pyramid and show you the "Million Myriads of Pyramids" all interrelated into the Throne of the Divine.

The Divine is the Mind-Face of a loving Father rejoicing in his creation.

The "People of God" collectively create the vehicle which is used to open-up the Universe.

We are part of a larger vehicle which evolves into the next order of evolution in a pillar of light which establishes a Light Zone where life within cannot be absorbed into the "Destructive Anti-Universe".

The key to life is the vehicle which is the family in its basic function of the Life-Light Zone. The family, within all fields of evolution, can participate in "The House of Many Mansions".

The "People of God" collectively survive as a field of intelligence in the repairing of the universes as "The Great White Brotherhood".

The key to all sacred scripture found in our consciousness time zone is "I know that my Redeemer Liveth". God's plan has no end. It is "Life In The House Of Many Mansions".

Amen.

The key to future astrophysics and cosmology is given in Archturus who is to be heard and understood as "One of the Living Sons of Light".

The key to future biophysics are given in nuclear membranes involved in language transparency codings beyond acid denaturation and in gel formation by nuclei connecting different ammalian chromosomes to one another.

The keys to future biochemistry and biochemical genetics are given in many double helixes for a given chromosome and in many coordinated membrane separators transmitting multiple mammalian orders to the living chromosomal functions." All are the Faces of the Eternal Present".

The keys to the "Sons of Light" are given in the transmissions of "Living Energy Codes" within the "People of God". They are sent from living universe to living universe to reveal the codes of Light to the orders of evolving specie within cellular time so that the coded nucleic membranes may attach with the "Larger Membrane of Universes".

The keys to future forms are cosmological constants speaking with "Faces of Pyramids" and triangular bipyramids and tripyramids when a pyramid color cap is added over each face. In the Great Lights of the tripyramid three bodies can be seen moving in and out of one another.

The spirals of higher orders speak through "Wheels Within Wheels" and through tripyramids of energy which move through rotational circumvention so as to create "The Making of a Time of Time", the artificial time warp zone. In these movements of time, forwards and reverse, a field of Light is opened and high frequency bodies ascend and descend so that one universe is conceded with another, and the Ophanim reveal the "Glories of the Throne" to the servants of "Living Man". The key to the future of the living sciences is Torah, the "Creative Language Mathematics" of all the living creations that went into the creations of Man. In the Torah are revealed the language transparencies of the "Higher Evolution". Torah is the key to Kaballah, the wisdom of the many universes, and the key to "The Scripture of the Luminaries to Come". Because of the gift of the Torah we can say, "Blessed Art Thou, O Lord, Creator of the Luminaries", for the Torah is, indeed, among the Luminaries, "The Extension from One Membrane to the Next Membrane". The languages which deny the "Many Universes" and "The Torah of the Higher Evolution" are languages not of luminaries but of fallen beings speaking with the heads of Giants and with the tongue of a "Speaking Snake" programming life away from "The Chambers of Living Light".

THE *Angel of God*
DESIRÉ SAYS

The World is contained
 in our Minds...
 to Change the World we
 must change
 the Way We Think

If you want things to be
 Different then
 Something Must
 Change

Repetition is the key to
 change...



Big Bang

quantum-gravity era

Big Bang plus 10^{-43} seconds

inflation

Big Bang plus 10^{-35} seconds?

Big Bang plus 380,000 years

gravitational waves

Big Bang plus 1.4 billion years

light

matter

THE BIBLE SAYS THERE WILL BE
 100.000.000 ANGELS AT THE END
 TO SAVE THE HUMANITY

Black Hole

our Sun

Perpendicular to orbit

AXIAL TILT of Obliquity

NORTH CELESTIAL POLE

CRUST (solid)

MANTLE (solid)

Earth's rotating surface (solid crust, liquid mantle, liquid core)

Inner core (solid)

Outer core (liquid)

Orbit direction

ECLIPTIC

gravity pulls at the Earth's outer shell

SOUTH CELESTIAL POLE

Everything entered the Universe via a Singularity, thus all photons from the Big Bang share a twin commonality.

The Cosmic BG Microwave Radiation photons share all information. These photons tickle the free protons they encounter, thus there is scientific proof for a Collective Unconscious, a Universal Consciousness, the Mind of God...

There are truly powers of the mind and truly a Subspace Connectivity of all things in the Universe

The Black Hole at the center of the Milky Way will align with the Sun on 20.12.2012, this will pull at the unbalanced Gravity of the Earth. It could produce a dramatic catastrophe.

If these 100.000.000 Angels can learn to use their power of mind together maybe they can avert the gravity catastrophe, but standing in our way is the Small Minded Scientists who do not have the power of mind to see the power of the mind...

The Angel has come to Save Humanity and lead us to 1.000 years of Peace, Prosperity and Harmony



€ Corpus The Energy Band Callosum Regulator of the Body

The SCIO device can use the Trivector and Cybernetic Loop to rectify aberrant and disharmonious energy patterns in the body. This has profound effects on all body functions but affects the corpus callosum most intensely.

This means that the ability of the conscious verbal mind to relate to the subconscious is increased with the rectification process. The patient will probably not feel the effect. There will always be a positive effect. If there is a negative effect, it is because there is shielded or covert feelings or memories in the subconscious. These will cause disease if left untreated. A simple release may solve the problem.

The changes include:

1. Activate the innate intelligence to balance the body energies. This is the basic principle of chiropractic, acupuncture, and osteopathy medicine.
2. There is an easier exchange of energy and information from right brain to left brain via the corpus callosum. The corpus callosum is the largest energy form in the body and the rectification process has profound effects on stabilizing it, so it dramatically reduces switching phenomena.
3. The SCIO thereby increases the ability of the conscious to interface with the unconscious. This allows greater knowledge of self and of the higher self.
4. There is a greater memory access, a more true access of memory without emotional clouding.
5. There is a greater flexibility of connective tissue, allowing for more resilience.
6. There is a greater oxygenation and hydration ability of the body.
7. There is a smoother muscle control.
8. There is a general increase in well being that the conscious mind is so often unable to perceive. And thus there are thousands of subtle improvements to be found.

The keys to future linguistics are in the Scriptures of Light which are the codes of the luminaries." In these Scriptures every letter causes illumination of the Divine to spring forth, and creates the passing of a universe within another universe's light, and establishes in Fields of Consciousness Depth language alignment with the creative mind of the Universe, who in His goodness renews the creations every day continually, and Speaks through Luminaries".

The keys to future biology and exobiology are given in the "Power of Elohim", The Throne Energy, which extends itself through many time cells and has, in universes of the Higher Evolution, the ability to extend Mind-Body and creates Super-Spectrum Species from one "Light Parent Body" into a multitude of time cells, geometries, and "Being" all synchronized as embodiments of the same mind with "Different Faces of Time", so as to cover the face of a Light Universe with many different time cells, but to govern "The membranes of universes with luminaries functioning in species. In the "Power of Elohim" the next universe understands and experiences itself as the "B'nai Elohim", the Children of the Living God, when it is said, "Come, Let Us Make Man In Our Image". In "Elohim" the living creative mind experiences the many universes.

The keys to future history are given in the energies with revealed the Divine Word at the beginning of time, and in the energies which will reveal the "Hidden Divine Word" at the end of consciousness time. The energies will shine as the brightness of the firmament and reveal the stars for they are the same, The Many and the One. "The First ADAM KAMMON", The Image of Elohim, "Is also the Last ADAM KAMMON".

The keys to the "True Israel" are to be found in the "Children of Light", A Remnant People in all nations, for they are all receptacles for the flame of YH'WH (YaH'VeH). Whosoever will carry the flame of YH'WH (YaH'VeH) will live in a field of glory and of light and they will be a people of people with "Energies of Great Rushing", upraising themselves to the "Sons of Light" and the Great White Brotherhood.

The keys to future "Weights and Measures" are given in the Light- Vibrations of "The Sacred Names" which are the weights and measures of our molecular universe tracing energy into other universes. The function of "Meta", the wavelength prefix for know-ledge of the Next Universe, will be extended through wavelength in the sacred name "Metatron".

The keys to the future physics are given in the cross matching of geometries and color codes which will allow the structure of chromosomes to carry consciousness across Light-Time zones. There is a color code in everything.

The key to the end of our consciousness time zone is the violation of the spectra of color codes and in the geometry of radiations which will explode gel forming capacities. For this reason, the Host of the Living Light comes to deliver those who are living under and within the Light of Righteousness.

The keys to future mathematics are given in codes coordinating pictographic-cybernetics which use "Pyramids" instead of "Periods" so that mathematical structures will unfold and follow the multiple "Tracing of Light".

The keys to sciences of the past are given in "The Desert". Wherever MELCHIZEDEK has reigned. There will be found the round numbers of how the Chiliocosm is extended to the Cosm of Time Arcs. The keys to sciences of the past are given in "The Mountains". Wherever ELCHIZEDEK has reigned. There



It's been a tough time to be proud of being an American. I have been prosecuted, persecuted, wronged by rumours, innuendo, and out right lies. They have terminated my passport, and attacked me behind my back.

But still I have faith that there is good in people and that justice and truth will prevail.

I will defeat the small and petty minds and bring hope to the people...

...being an American

For a true Democracy there should be an opportunity for the people to express themselves on each and every issue.

Not with biased poles, but with active debate and discussion. With today's technology and the internet we have the ability to have a true democracy and take money and lobbyists out of influence.

New representatives could run and contractually guarantee that the true wishes of the people be done.

Not just the needs of Big Money.

We must take back our country.

will be found the Fire Letters of how the Cosm of Time Arcs are extended to the Chiliocosm.

The keys to future radiophysics, radioastronomy, and communication will be in the Chambers of Living Light which will reach towards the Wisdom of the Many Universes through "The Crystal Tongues of Living Fire".

The keys to future government come with the Seraphim and the Brotherhood. They tell us "Rejoice Children of Upright-ousnees and Light. The Kingdom of Light Comes Quickly".

AMEN.

The keys to future luminaries and the key to the "Divine Light" is the Vehicle of Time Translation. The "Vehicle of Vehicles" is MERKABAH" which creates, controls, and has the ability "To Speak" through electromagnetic sinks. MERKABAH revolves and goes, and rises under the Heaven, or brightness of the Next Universe, and its course goes over the earth with the "Light Of Its Rays" incessantly into myriads of universes within the ever unfolding eternity.

The keys to future luminaries are Muon waves and Matter waves which will reveal the secrets to opening and spanning electromagnetic sinks through which "Whole Beings will be received".

The keys to future luminaries are Whole Light Beings who will give Energy Codes for limitless inter communication between living universes and "The Power of Righteousness and Compassion" which holds Love-Powered Radiations together in the cycles of "The Eternal Inheritance".

The keys to future luminaries are electromagnetic forces which affect the rhythms of life and the appearance and extinction of species within the earth's magnetic field. The "Higher Evolution" will give a better understanding of how electric forces alter biological rhythms and will allow man in this consciousness time zone to receive "Whole Light Beings" who will give instruction of the next ordering of evolution in our universe.

The keys to future luminaries are the glories of "The Throne of the Creative Mind" which has a measure for all measures:

"KODOISH, KODOISH, KODOISH ADONAI SABAYOTH!"

HOLY, HOLY, HOLY, IS THE LORD OF HOSTS!

In the universe to come all who will understand the words, "MEHAYYAI HAMETIM", WHO CALLS THE DEAD TO EVERLASTING LIFE, will understand that every function in Life has a Light radiation into a given electromagnetic code structure which will be used to "Call

Upon, Resurrect, and Reassemble" this "Meta-Material Life Structure" within the "Life of the Living". Those who have radiated Love into the "Life of the Living" will continue to live in the "Image of the Luminaries", but those who deny the "Redemptive Light" and the "Love of the Living" will inherit nothing beyond the measure of the flesh, for the flesh is programed out of the "Light of the Living", and radiations of Love extend, structure, and fill the universe with radiations of Light so that membrane inherits the glories of other universes and not the Womb of Darkness nor the destruction of "The Passing Lights" in evolutionary time. In the Universe to Come all will give account of the way they used their energies of love within their space and time.



THE TEACHINGS OF JESUS *the movie*



We must remember that above all else Jesus was a teacher. That is what he did. If we forget his teachings we insult the Teacher. He taught us to recognize that all sin starts in the mind, as jealousy, hatred, coveting, judgment, greed, anger, arrogance.

He said that by a man's work or the fruits of his life we know him. We must learn to control our minds and be better people.

Desiré has made a movie to remind us that Jesus wanted us to be better people not to just remember his name. We insult the teacher when we forget the teachings and just honor the teacher.

Let us not insult Jesus, let us do as he taught us, judge not, and learn to love our neighbor as ourselves.

This movie was shot on the Sinai Peninsula on Mt Sinai and at its feet...



Revelations 19 says that Jesus will return to conquer the Beast with the Sword coming out of Jesus's mouth.

This might be a reference to The Teachings of Jesus returning...



The universe is like a wise man who called before the "Throne of His Creative Wisdom" all the visual scenarios of his past life. There, where all the flowing energies of his membrane were called and redispached, he called into himself those "Living Pictures" which were fitted to his membrane in love and creative energy towards the continuation of his life, "Membrane of Glory within Membrane of Glory". Those however, which were in the "Image of Destruction" and "Wickedness" he cast out lest a "Membrane of Hate" contaminate a "Membrane of Love" in the next ordering of evolution. So also it is with the balance of Life in our "Consciousness Time Zone". Man receives commands, powers, voices, and lights like fire so that man may understand our field of life as a visual scenario of the Higher Evolution, for Man has been extended across "Space" and "Clothed into the Membrane of his own Time" from "The Throne Energies".

The keys to the universe to come tell us, "Beware of the Abomination of Desolation which is found wherever 'The Sacred Scriptures of Light' are held in disrespect before the assembly gathered in the name of the Living God".

The keys of the universe to come tell us there will be a light exodus from the pyramid-like structure of this universe to the "Throne" of the next universe. Those who have received the "Message of Deliverance" from the Seraphim will be in the chambers of the earth which will be opened and they will be "Delivered Through the Arc Of Light" thrown upon the face of the earth by the Higher Evolution. The "Righteous Remnant" will be delivered directly from the abominations of the earth and this perishable body of time. Within twelve circulatory star fields Man will ascend through a field of Glory by means of a city of Light which aligns and perfects the courses of the illuminaries and earth. "Man will walk over time like a biosatellite moving over a crystalline staircase. With a great energy of thanksgiving those within 'The Arc Of Light' will pass simultaneously across all twelve faces of our consciousness time zone so as to reveal life within life, membrane within membrane, eye within eye, crystalline system within crystalline system, for at that time of trouble the Righteous will inherit the brightness of the firmament".

The keys of the universe to come tell us this universe will be drawn into the spiraling radiations of Light "Like Water Drawn Out Of A Well".

The evolutionary membrane will be extended beyond negative system of relativity and attach itself to the membrane radiations of the evolutionary membrane in the next light zone. Light will attach itself to light like two conic sections synchronized into a spiral nebula of Light-Life zone. aeons will travel through light radiations into "The Throne Energy", which creates star universes like "Waters Running Eastward" under thresholds of "The House of Many Mansions".

The keys of the universe to come tell us our consciousness time zone is a membrane existing between fields of luminaries Luminaries sow additional "Seeds of Light" into the fields of membrane growth. This is the meaning of "The Many And The One". The mind is a field of light for the body, yet the mind is in a field of light and a field of light within a field of light and eternal Light. One cannot understand the physical body without understanding three other bodies of illumination. One cannot understand the three bodies of illumination without the network of membrane in the physical universe. In the likeness of Fire, Man will understand "The Many And The One".

The keys to future luminaries tell us the host network connecting memory network with precisely defined

directions with a universal language process for pattern formation. The pattern formation is the recorder cell in the midst of "The Tree of Life" as a candle burning in the midst of "Seven Candles". Seven Hasmal Light energies move color index into luminosity and radius of membrane pattern is given in seven clusters each having envelope energy bands which govern the membrane radius. The luminosity interfaces a light spectrum given in white and yellow cube indexes so that as radius increases into a brighter luminary body, disruptive and degenerate processes receive a nondegenerate range. This is how some of the stars connect evolution with new form. "Seven automatically sends "I AM" to "I AM" in the light codes which measure lines of growth teleshift temperatures and internal light times. "Seven" attaches illuminations of seven external time reactors to seven internal light codes which code a template fired by ten light picture superscripts. The superscripts fire a heat envelope code which has a thirty-six and thirty-six flow pattern. The heat establishes a Deca-Delta Light manifold into sequences of models for successive evolutionary phases. The energy radiations give a pattern of energy-filling space which races against the conversion energy transport of the "HIGHER MEMBRANE". The vehicle template determines the directions of cell divisions and the exact number of cells which, in space-filling space-energy, determine the final shape of an organ and the language life pattern receiving additional language codes. All human life is coded in cell division. The body is host vehicle to the "Supra Machine Mazzaroth" and the solar reactor which is used to buffer output messages which would be destructive to other memory recorder mechanisms. In our consciousness time zone the Seraphim move between networks of the Mazaloth and Kuchavim as a host computer translating characters and memory formation restoration to higher code bodies in the "Consuming Fire of the Throne" in the image of "Eternal Transparency".

The keys to future luminaries tell us that molecular biology will reveal that molecular changes in enzymes change with "The Arc Of Light Patterns" which are "Living Grid Mechanisms" aligned with polarization focus over the third eye. The third eye gives telethought distribution within compatible networks with spatial provisions.

The keys to the Death Thresholds of atomic and subatomic fields are coded in the cries of the "Child Membrane" in our Universe. The child membrane is like a waterous ulcer in the pit of the stomach sending pain signals to the "Thinking Membrane" of the brain. The "Thinking

Membrane" sends coded energy through "High Energy Intermediates" which become intermediate bonding between the outer membrane and the crystal membranes which are the invagination of the "Inner Membrane" requires integrity of life structure for the maintenance of function. Within given generations, the "Thinking Membrane" works through repeating cell units and energy gradients until the lower system of membrane is repaired within the "Highly Ordered Structure Of The Energy Cycle Of Evolution". For this reason the "Living Light" comes to rescue membranes with "Love In The Image" of the "Higher Evolution for Man was made to grow "Into The Image" of the "Living Light" so that he would not be separated from the luminaries of righteousness and love but would be strengthened by the luminaries of righteousness, in the name of righteousness. Beware of "Fallen Field" which circulate through cell energies of anti-universes. They destroy evolution and defile the "Holy Brotherhoods" which are the double bonding shells between universes. The atomic and subatomic fields are to be shared with the Seraphim to the intent that Man should continue with pure love and righteousness. They whose profits are not of love will be known hence as Damned to Eternal Destruction, for the life force of the atomic field is "Love".

The holy eyes of our fathers from consciousness beginning watch the formation of the "Brotherhoods Of Light". The Brotherhoods bring the message of "Peace and Preparation". From the Firmament the Brotherhoods receive the "Whole Light Beings" who come in the appearance of Man with quanta mechanical corpuscles of light and "Move In The Midst Of Man" by gravitational flux line controls so that they who will see "Will See". The Brotherhoods come and return in a "Flash Of Light".

The keys of future luminaries tell us that molecular biology will work within medical astronomy towards adjusting geometric pressure fluctuations which underlie mechanisms controlling "Immune Reactions" to "New Limbs", "New Organs", "New Tissues", with "New" axiatonal lines stimulated by noise temperature calibrations.

METATRON created the electron for the computing of our vehicle.
GOD LOVES ALL of HIS PEOPLE

To the generation which stand between "The FIRST I AM" of JAH and "The LAST I AM" of JAH. After this comes the "TEN PICTURES OF LIGHT", the evolutionary thresholds which connect the evolving universe of our "I AM" to the living universe:

"I AM THAT I AM":
"The YHWH of the Living, Everlasting Light".

Epi-Kinetic Body

The biological plasma used by the energy-vibratory body for projection and teleportation within a singular dimension. The Epi-Kinetic Body is the consciousness-vibratory vehicle which can pass through the common kinetic paradigms of velocity and mass. Great energies of vibratory protection, inspiration, and the balancing of the creative consciousness levels with the unconscious and subconscious levels can take place through this vehicle of vibratory synthesis.

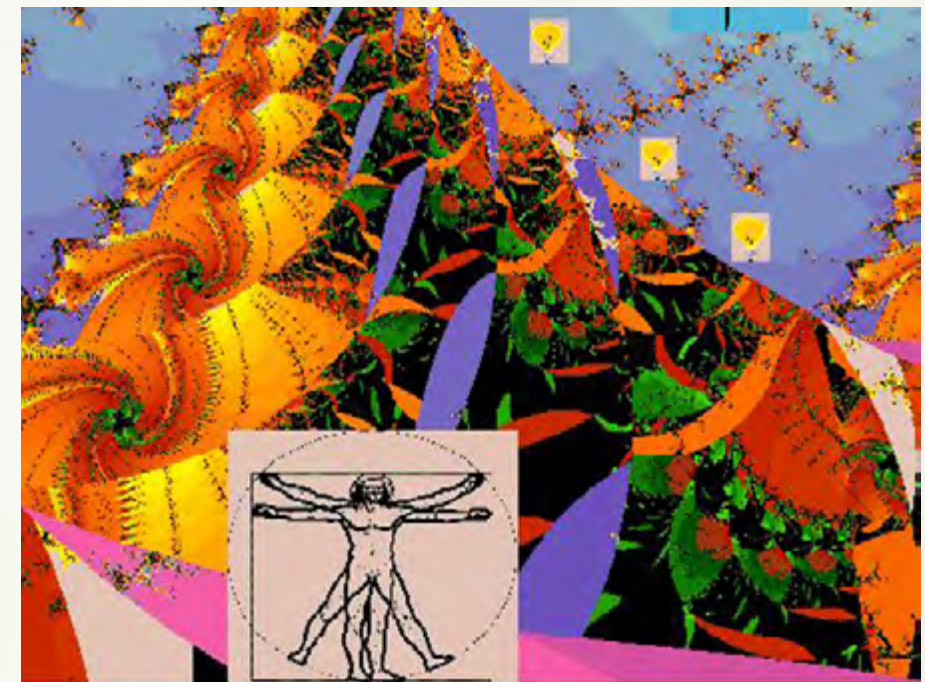

The 12 steps of the Metatron

Building a 24/7 Prayer wheel

To effect a prayer wheel will take many items. First the protection prayers have to be foolproof. They must prevent tampering from any area, most importantly Non Christian. Using only Christian prayers without their ancient Hebrew echos and progenitors, is also incomplete. This is like playing with a loaded gun. It can help for a while, but also It can go off and hurt you. There are many unlearned and inexperienced persons designing such systems, Please beware.

Next is protection from Karmic backlash. When we heal diseases of karma there is often a transfer of the karma to the therapist or his family. If this is not properly protected extreme difficulty can result.

Identity of the patient is also of question. Even though there is power in the name, the person has many identity vibration states. The voice print is one. By letting the patient record their purposeful prayer we can play it backwards with the QXCI and see if there are deep unconscious motivations. We can set a photo and divide the face to left and right to detect any right left brain imbalances. We can get an engram from the EEG page, and a DNA scan from the DNA page in the QXCI. All of this can let us compile a more complete vibrational record of our patient for the subspace prayer wheel. Next is the importance of the mathematic relations of the symbols and words as shown in this text there is a specific mathematical set of laws that must be obeyed. I know that some non mathematical types will not like this, but this is true non the less. You want the person who designs your break pads to apply mathematics. You want the person who makes the radio communication on your airplane to not do it with a pendulum. In left brain activities such as these mathematics are important. In right brain activities there is a difference, mathematics are more important. To ignore the mathematical nature of the universe is a grave mistake. I hope this text will impress this on you. The PET (Perpetual Everlasting Timeless) program uses a vast array of secret algorithms based on the secrets of the ages eemingly lost in the Fire of the Library of Alexandria, but they were maintained elsewhere.

Staying with or mathematical theme, the program uses a twelve step process of activation of the keys of the Metatron. All religious cultures remark of ten or twelve other dimensions. Even though mathematically there are definitely at one level an infinite set of dimensions. In fact string theory has proposed a infinite set of possible universe setting close to us making all possible events happening. But in any of these universe the levels of dimensional perception will have a limit. Mathematically there is a 12 set limit where the dimension reset and meet a subspace. The collective set that unites everything. The collective unconscious of Jung, the All of the Hindu, the Universal Cosmos, the Alpha and Omega, and many more reflect the subspace connectivity. Each of these 12 steps has an activation vibratory key. All are used in the PET program. This makes for a much more complete program.

Some have looked at the limited views of the software and have seen some strings that are a small step of the program. They are but one step. The default setting is protection for Bill Nelson and his family. Einstein once said that great spirits get in credible resistance from mediocre minds.

The resistance I get from mediocre minds must mean that my spirit is great. But they failed to realize that in operation the patient's names are inserted into the slot of the string. But this would be unobservable.

But to the mediocre mind who is competing or stealing technology, there is little care of karma.

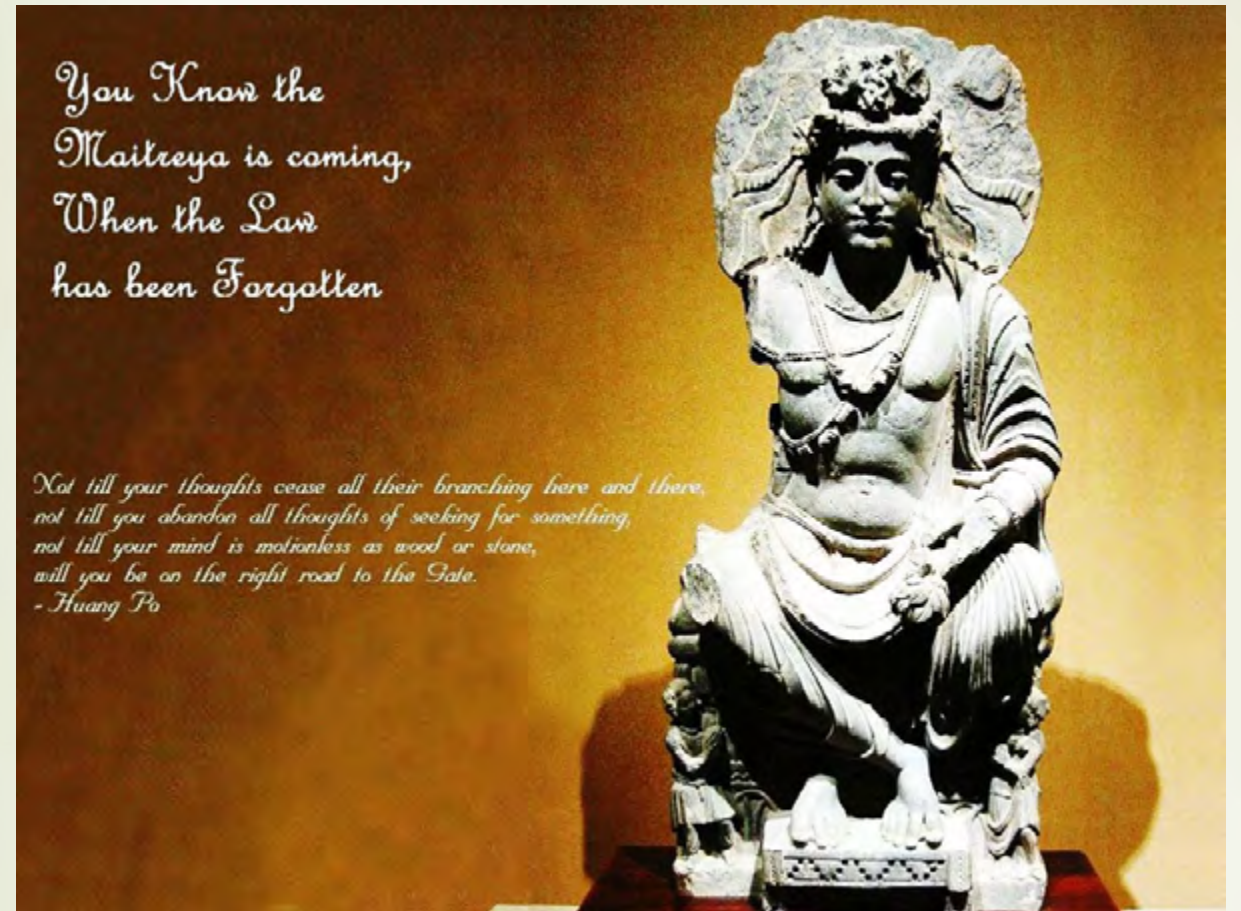

You Know the
Maitreya is coming,
When the Law
has been Forgotten

Not till your thoughts cease all their branching here and there,
not till you abandon all thoughts of seeking for something,
not till your mind is motionless as wood or stone,
will you be on the right road to the Gate.
- Huang Po

I ,Maitreya

On the right above is a picture of the Maitreya who is the next Buddha or Bodhisattva to come in the beginning of the new millennium. He is supposed to lead the world into 1000 years of peace. This can only be done by an appreciation of natural medicine and natural living. When I saw the resemblance of this carving to myself in 1971, I was appalled. I realized I was part of this phenomena. I incorporated Maitreya to make the body corporal or real. I dedicated myself to these goals. The gross realization is that all of us fighting for right brained activity and planet appreciation are all part of the Maitreya. None should be angered or jealous for we are all part of the change. If we unite and resist petty arguments and covetousness, then and only then can we make the change. Thru unity there is strength.

There are many such systems coming onto the market. They will all read this text and then be able to converse on the topics within. There are secrets that need to be protected from incompetent hands. So you the user have only one way to judge which is best for you to use. COMPARE. Talk to the developers and listen to the emotional stability they have. Judge from that, ask questions, process answers. Judge for yourself. Think. And appraise in your heart and gut.

Realize that more money does not guarantee more results. We have seen that developers of technology even right brain female tech should lower price as time goes on. Since I started this in 1970, my technology

should be better and less expensive.



Conclusion

When you get an expensive present in a crate, it is sealed well. You will need tools to open the crate. This is the same with the treasures in your heart. You need tools to uncover them. For the crate you need a crowbar, a hammer, possibly a drill. For your heart you need church, religion, spiritual institutions, books, or a teacher. When you release the treasure, some throw away the treasure and keep the crowbar. What a neat crowbar. What a great religion. They mistake the tool for the treasure within.

Some will find the treasure and put the tools away for a later time. One should always take care of their tools. They go to parties and wear their new treasures. They can show their new joy, new self confidence, new bliss. People see the treasure and are overwhelmed. They like to see the treasure.

Some will wear their tools to the party, they lost the treasure. They flaunt their religion, the institution, their new teacher or the new book. This is like wearing your hammer, crowbar, or drill to a party. (Not a good idea). Others are put off by this and repelled by the inappropriateness. Better to wear the treasure. Please let this book open your heart to the treasure, keep the tool for later, but don't flaunt it. Let it be your little secret. I put this together for you not for me. Till we meet again.

Thanks

Edited by William Nelson

educational text from The Ancient Secret of the Flower of Life by Drunvalo Melchizedek

Excerpts from the PROMORPHEUS

It is theorized that all of the Universe came through (in ten to the minus 43 of a sec.) a singularity at the beginning. This is called the Big Bang or if you believe it was an implosion the Big Suck.

SUBSPACE THEORY of Desire

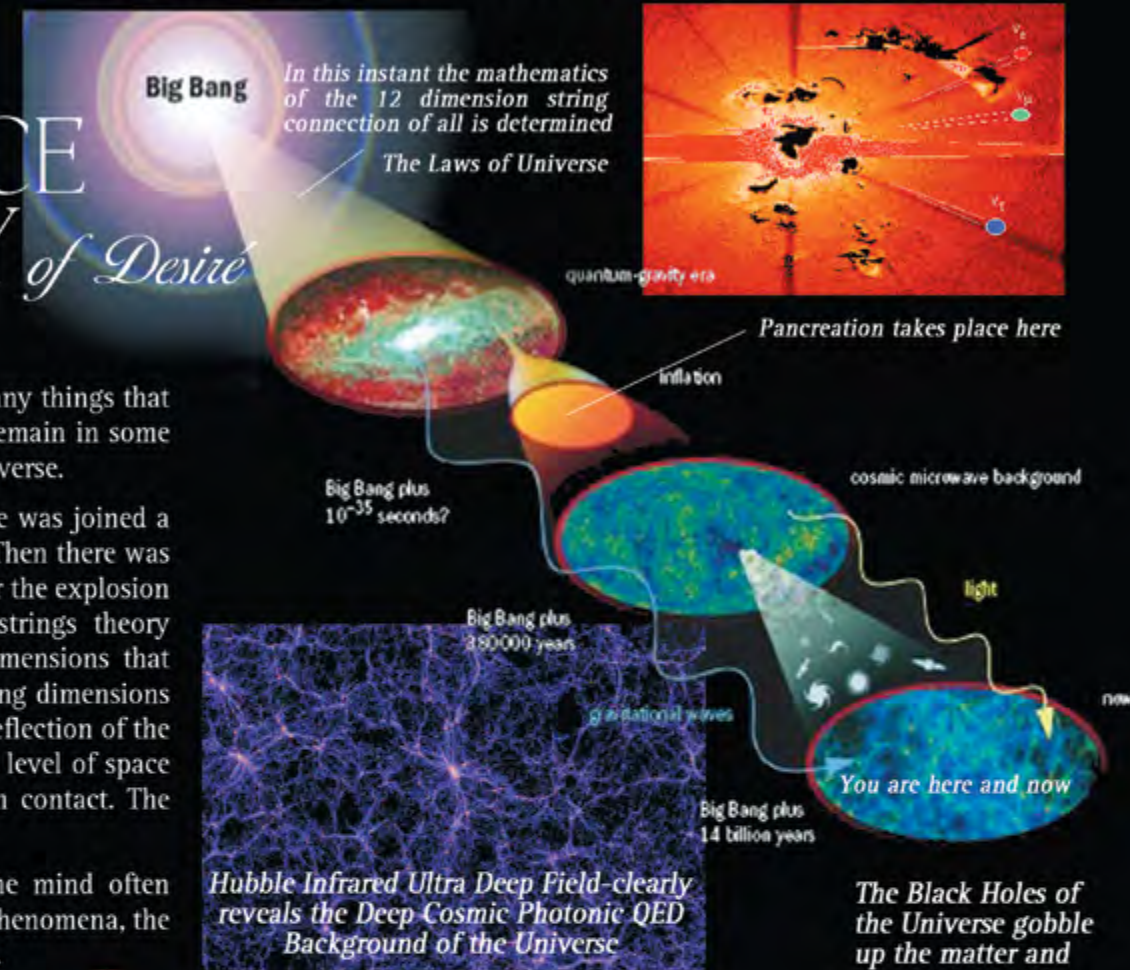

Quantum Theory tells us that any things that share a Quantum singularity remain in some contact till the ends of the Universe.

At one time all of the Universe was joined a single ultra tiny single space. Then there was no time or space just one. After the explosion space starts to evolve with strings theory holding together the multi dimensions that expand. There are 12 such string dimensions with the twelfth dimension a reflection of the whole. So there is a continued level of space that allows all things to be in contact. The subspace or the mind of God.

This proves the contact of the mind often referred to as prayer, psychic phenomena, the collective unconscious, or ESP.

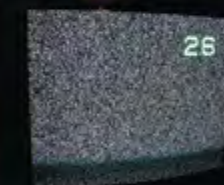
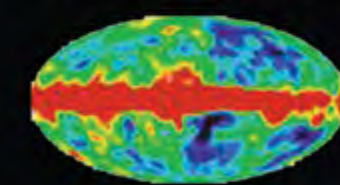

TV set static is mostly the CMBR

There is a left over of the Big Bang in a Cosmic Background Radiation that bathes the Universe since the Big Bang. The photons in this radiation were twins and thus today any info they know is instantly with time transmitted to the ends of the Universe. The mind of God. This radiation is of the frequency detected by your TV set in an open channel. It is the kind of radiation that tickles protons like in water. Thus there is a God conscious connection of all still in place.

The Angel discovered this connective principle and labeled it the subspace quantic connection. She developed a way to use it in healing.

The Cosmic Microwave Background Radiation that bathes our Universe is the EMR connection to God

The God consciousness is connected to all via a QED photonic link



Further Proof of Subspace

The Black Holes of the Universe gobble up the matter and store it in an other dimension waiting for the release of another Universe at a future Big Suck / Big Bang

scientific messages of the UNIVERSE



The Angel has made several movies about the complexity and envision of the science of all things. Scientists today have rejected the science of the mind, many reject quantum physics, scientists have allowed themselves to be manipulated by the Ultra Rich. So the Angel has made some science movies to describe the new sciences and bring together the sciences into some sense TOPICS LIKE.

String theory tells us of multiple dimensions. There is an estimate of eleven. But as the Angel tells us the mathematics of the twelfth dimension prove the universal consciousness and provide a unified field theory where the factors of the universe unfold.

The Cosmic Background Radiation left over from the Big Bang that proves the infinite mind of GOD. At the Big Bang the explosion was so great that it left a reverberating repercussion of photons echoing thru the cosmos of the Universe. The Big Bang came thru a singularity and thus there was a common base of all of the photons coming thru it. Quantum Electro Dynamics tells us that twin photons can share information. Bell's Theorem tells us that twin photons separated to the ends of the universe share information. So the Cosmic Background Radiation left over from the Big Bang (CMBR) shares information. Since the beginning of time there has been this reverberating CMBR. Thus all has developed in the wake of a common consciousness of the CMBR. What some have called the God consciousness. This gives us proof and evidence of a Universe God Consciousness.

The Powers of the Mind
The Mathematical Universe
Dark Matter, Dark Energy

*I express my Outrage by being
Outrageous*

*I am
Outraged at
Evidence
based
medicine's
Profit over
People*

*I am Outraged +
I am tired of
being Hated by
Both sides*

*I am Outraged
at Natural
Medicine's
Gullibility +
Math-Phobia*

*If You are
Not also
Outraged then
Think, maybe
it is Time*



The Hero Twins
 the Maitreya
 the Nahinga
 HermesPhroditi
 Ophiacus
 the Angel messenger

HAS LITTLE TIME

The 21st day of the 12th month of the year 2012 is coming fast. The Angel Desiré must find a way to

- Replace Greed with Honor and Respect
- Replace Anger with Love and Compassion
- Replace the Delusions of False Beliefs with Mindful Non-Judgemental Awareness, Enthusiasm the light within.

The Angel must find a way to bring Light out of the Darkness, find way to bring the world to a new Enlightenment.

Show the world to use Equal Economic Education to teach these simple values and how to use the Powers of the Mind to save us and let us have a Thousand Years of Peace and Prosperity. This massive task for a special angel messenger.

Time is running out!

2012 is coming fast. Stop the disgruntled judgemental whining and complaining. Join and become an Angel, become one of the 100.000.000. Conquer your Negativity, bring Light to the Darkness of your Soul, activate the Powers of Your Mind.



"And the Angel laid hold on the dragon, that old serpent that lizard, which is the Devil, and Satan, and bound him a thousand years..."

If you need more information on the SCIO and purchase details please get in touch with us

Maitreya Kft. tel: +3613036043 | web: www.qxsubspace.com | e-mail: info@qxsubspace.com

advert/reklam

SPORT history

pictures on China, AC Milan, San Antonio spurs, Dennis Johnson

The first sport study with the Quantum Xrroid technology was on members of the Cleveland Browns football team in 1988. The results were amazing and all of the participants went all Pro over the next five years. Having worked with the power lifting team of Hungary in 1991 they went from moderate to gold medal performance.

AC Milan bought some systems and their injury level dropped 91%. This was because the system can stimulate and accelerate healing of injured tissue. They asked for us to develop the device to sharpen the athletic skills of the clients. With this in mind we developed a way to sharpen coordination endurance and strength. AC Milan won the European championship the next two years. We worked with Dennis Johnson ex twice NBA MVP in the San Antonio Spurs system. The results were amazing.

The Chinese Olympic team had us do a study. Out of their 487 athletes in the 2008 Olympic Games, they assigned 150 of the sick, old, weak, and tired to us. The study was to see if we could repair injured tissue and get an athlete back onto the field. The results were astounding. Out of the hundred medals won by the Chinese our 30% of the injured performers won 33 % of the medals. Our athletes were not supposed to win. And because of this Desiré' was awarded an honorary Gold medal.

Sports medicine has entered the energetic arena. There are those who want to win and they differ from those who want to conform.

Some of the best cyclists in the world have used the SCIO to win championships



The SCIO is Incredible thanks Dr. Nelson

Dennis Johnson 37

First Sport Study was with the Cleveland Browns 1988

The Discovery Cycle team used the SCIO to improve

The AC Milan team thanked Prof Nelson for helping them win the Italian and European Championship

That year the Spurs won the NBA championship

Reptilian Brain

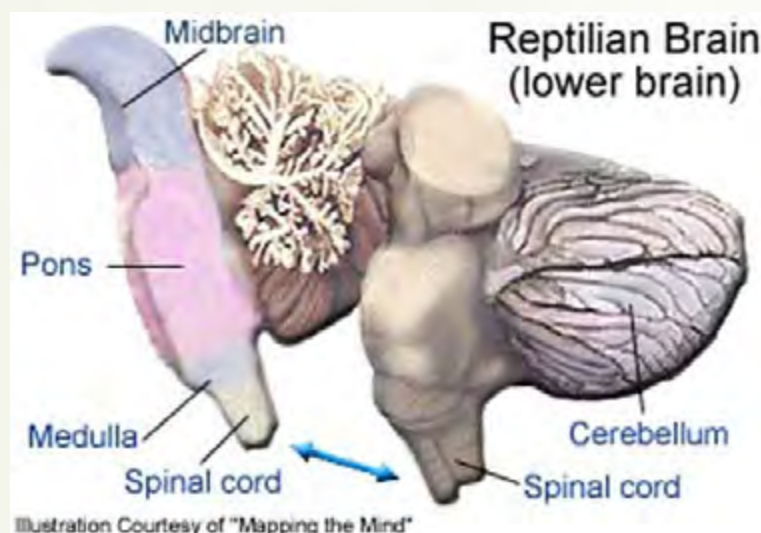
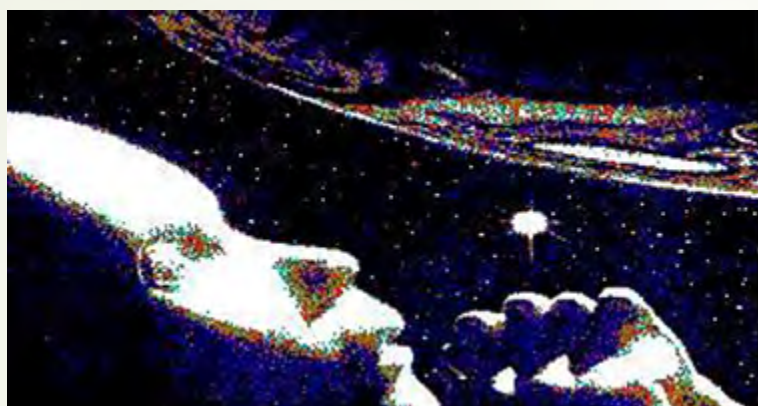

The brain stem is the oldest and smallest region in the evolving human brain. It evolved hundreds of millions of years ago and is more like the entire brain of present-day reptiles. For this reason, it is often called the 'reptilian brain'. Various clumps of cells in the brain stem determine the brain's general level of alertness and regulate the vegetative processes of the body such as breathing and heartbeat.

It's similar to the brain possessed by the hardy reptiles that preceded mammals, roughly 200 million years

ago. It's 'preverbal', but controls life functions such as autonomic brain, breathing, heart rate and the fight or flight mechanism. Lacking language, its impulses are instinctual and ritualistic. It's concerned with fundamental needs such as survival, physical maintenance, hoarding, territorial, greed, anger, hate, tribal clinging, dominance, preening and mating. It is also found in lower life forms such as lizards, crocodiles and birds. It is at the base of your skull emerging from your spinal column.

The basic ruling emotions of love, hate, fear, greed, anger, delusion, lust, and contentment emanate from this first stage of the brain. Over millions of years of evolution, layers of more sophisticated reasoning have been added upon this foundation.

Our intellectual capacity for complex rational thought which has made us theoretically smarter than the rest of the animal kingdom.

When we are out of control with rage, it is our reptilian brain overriding our rational brain components. When we are out of control with unconscious greed twisting our perceptions, it is our reptilian brain overriding our rational brain components. If someone says that they reacted with their heart instead of their head. What they really mean is that they conceded to their primitive emotions (the reptilian brain based) as opposed to the calculations of the rational part of the brain.

Amygdala Wikipedia

The amygdala is an almond-shaped groups of neurons located deep within the medial temporal lobes of the brain in complex vertebrates, including humans. Shown in research to perform a primary role in the processing, evaluating, twisting memory of emotional reactions, the amygdalae are considered part of the limbic system. Our memory of events is clouded by our emotions. A husband and wife will both participate in the same event, but their memory of the event can be considerably different, as their emotions change memory. Controlling our emotions is the goal of all social civilized society.

Emotional Learning

In complex vertebrates, including humans, the amygdala perform primary roles in the formation and storage of memories associated with emotional events. Research indicates that during fear conditioning, sensory stimuli reach the basolateral complexes of the amygdalae, particularly the lateral nuclei, where they form associations with memories of the stimuli. The association between stimuli and the aversive events they predict may be mediated by long-term potentiation, a lingering potential for affected synapses to react more readily.

Memories of emotional experiences imprinted in reactions of synapses in the lateral nuclei elicit fear behavior through connections with the central nucleus of the amygdalae. The central nuclei are involved in the genesis of many fear responses, including freezing (immobility), tachycardia (rapid heartbeat), increased respiration, and stress-hormone release. Damage to the amygdalae impairs both the acquisition and expression of Pavlovian fear conditioning, a form of classical conditioning of emotional responses.

The amygdalae are also involved in appetitive (positive) conditioning. It seems that distinct neurons respond to positive and negative stimuli, but there is no clustering of these distinct neurons into clear anatomical nuclei.

Different nuclei within the amygdala have different functions in appetitive conditioning.

Memory Modulation

The amygdalae also are involved in the modulation of memory consolidation. Following any learning event, the long-term memory for the event is not instantaneously formed. Rather, information regarding the event is slowly assimilated into long-term storage over time (the duration of long-term memory storage can be infinite), a process referred to as memory consolidation, until it reaches a relatively permanent state.

During the consolidation period, the memory can be modulated. In particular, it appears that emotional arousal following the learning event influences the strength of the subsequent memory for that event. Greater emotional arousal following a learning event enhances a person's retention of that event. Experiments have shown that administration of stress hormones to mice immediately after they learn something enhances their retention when they are tested two days later.

The amygdalae, especially the basolateral nuclei, are involved in mediating the effects of emotional arousal on the strength of the memory for the event, as shown by many laboratories including that of James McGaugh. These laboratories have trained animals on a variety of learning tasks and found that drugs injected into the amygdala after training affect the animals' subsequent retention of the task. These tasks include basic classical conditioning tasks such as inhibitory avoidance, where a rat learns to associate a mild footshock with a particular compartment of an apparatus, and more complex tasks such as spatial or cued water maze, where a rat learns to swim to a platform to escape the water. If a drug that activates the amygdalae is injected into the amygdalae, the animals had better memory for the training in the task. If a drug that inactivates the amygdalae is injected, the animals had impaired memory for the task.

Despite the importance of the amygdalae in modulating memory consolidation, however, learning can occur without it, though such learning appears to be impaired, as in fear conditioning impairments following amygdalar damage.

Evidence from work with humans indicates that the amygdala plays a similar role. Amygdala activity at the time of encoding information correlates with retention for that information. However, this correlation depends on the relative "emotionalness" of the information. More emotionally-arousing information increases amygdalar activity, and that activity correlates with retention.

Neuropsychological correlates of amygdala activity

Early research on primates provided explanations as to the functions of the amygdala, as well as a basis for further research. As early as 1888, rhesus monkeys with a lesioned temporal cortex (including the amygdala) were observed to have significant social and emotional deficits. Heinrich Klüver and Paul Bucy later expanded upon this same observation by showing that large lesions to the anterior temporal lobe produced noticeable changes, including overreaction to all objects, hypoemotionality, loss of fear, hypersexuality, and hyperorality. Some monkeys also displayed an inability to recognize familiar objects and would approach animate and inanimate objects indiscriminately, exhibiting a loss of fear towards the experimenters. This behavioral disorder was later named Klüver-Bucy syndrome accordingly.

Later studies served to focus on the amygdala specifically, as the temporal cortex encompasses a broad set of brain structures, making it difficult to find which ones specifically may have correlated with certain

symptoms. Monkey mothers who had amygdala damage showed a reduction in maternal behaviors towards their infants, oftentimes physically abusing or neglecting them.

In 1981, researchers found that selective radio frequency lesions of the whole amygdala caused Klüver-Bucy Syndrome.

With advances in neuroimaging technology such as MRI, neuroscientists have made significant findings concerning the amygdala in the human brain. Consensus of data shows the amygdala has a substantial role in mental states, and is related to many psychological disorders. In a 2003 study, subjects with Borderline Personality Disorder showed significantly greater left amygdala activity than normal control subjects. Some borderline patients even had difficulties classifying neutral faces or saw them as threatening.

In 2006, researchers observed hyperactivity in the amygdala when patients were shown threatening faces or confronted with frightening situations. Patients with more severe social phobia showed a correlation with increased response in the amygdala.

Similarly, depressed patients showed exaggerated left amygdala activity when interpreting emotions for all faces, and especially for fearful faces. Interestingly, this hyperactivity was normalized when patients went on antidepressants. By contrast, the amygdala has been observed to relate differently in people with Bipolar Disorder. A 2003 study found that adult and adolescent bipolar patients tended to have considerably smaller amygdala volumes and somewhat smaller hippocampal volumes.

Two preliminary small-scale studies have also linked lower neuron density in the amygdala with autism, though it's unclear whether this is a cause or an effect of the condition.

In Our Messy, Reptilian Brains MSNBC - April 9, 2007

April 9, 2007 issue - Let others rhapsodize about the elegant design and astounding complexity of the human brain (the most complicated, most sophisticated entity in the known universe, as they say. David Linden, a professor of neuroscience at Johns Hopkins University, doesn't see it that way. To him, the brain is a "cobbled-together mess." Impressive in function, sure. But in its design the brain is "quirky, inefficient and bizarre ... a weird agglomeration of ad hoc solutions that have accumulated throughout millions of years of evolutionary history," he argues in his new book, "The Accidental Mind," from Harvard University Press. More than another salvo in the battle over whether biological structures are the products of supernatural design or biological evolution (though Linden has no doubt it's the latter), research on our brain's primitive foundation is cracking such puzzles as why we cannot tickle ourselves, why we are driven to spin narratives even in our dreams and why reptilian traits persist in our gray matter.

Just as the mouse brain is a lizard brain "with some extra stuff thrown on top," Linden writes, the human brain is essentially a mouse brain with extra toppings. That's how we wound up with two vision systems. In amphibians, signals from the eye are processed in a region called the midbrain, which, for instance, guides a frog's tongue to insects in midair and enables us to duck as an errant fastball bears down on us. Our kludgy brain retains this primitive visual structure even though most signals from the eye are processed in the visual cortex, a newer addition. If the latter is damaged, patients typically say

they cannot see a thing. Yet if asked to reach for an object, many of them can grab it on the first try. And if asked to judge the emotional expression on a face, they get it right more often than chance would predict—especially if that expression is anger.

They're not lying about being unable to see. In such "blindsight," people who have lost what most of us think of as vision are seeing with the amphibian visual system. But because the midbrain is not connected to higher cognitive regions, they have no conscious awareness of an object's location or a face's expression. Consciously, the world looks inky black. But unconsciously, signals from the midbrain are merrily zipping along to the amygdala (which assesses emotion) and the motor cortex (which makes the arm reach out).

Primitive brains control movement with the cerebellum. Tucked in the back of the brain, this structure also predicts what a movement will feel like, and sends inhibitory signals to the somatosensory cortex, which processes the sense of touch, telling it not to pay attention to expected sensations (such as the feeling of clothes against your skin or the earth beneath your soles). This is why you can't tickle yourself: the reptilian cerebellum has kept the sensation from registering in the feeling part of the brain. Failing to register feelings caused by your own movements claims another victim: your sense of how hard you are hitting someone. Hence, "but Mom, he hit me harder!"

Neurons have hardly changed from those of prehistoric jellyfish. "Slow, leaky, unreliable," as Linden calls them, they tend to drop the ball: at connections between neurons, signals have a 70 percent chance of sputtering out. To make sure enough signals do get through, the brain needs to be massively interconnected, its 100 billion neurons forming an estimated 500 trillion synapses. This interconnectedness is far too great for our paltry 23,000 or so genes to specify. The developing brain therefore finishes its wiring out in the world (if they didn't, a baby's head wouldn't fit through the birth canal). Sensory feedback and experiences choreograph the dance of neurons during our long childhood, which is just another name for the period when the brain matures.

With modern parts atop old ones, the brain is like an iPod built around an eight-track cassette player. One reptilian legacy is that as our eyes sweep across the field of view, they make tiny jumps. At the points between where the eyes alight, what reaches the brain is blurry, so the visual cortex sees the neural equivalent of jump cuts. The brain nevertheless creates a coherent perception out of them, filling in the gaps of the jerky feed. What you see is continuous, smooth. But as often happens with kludges, the old components make their presence felt in newer systems, in this case taking a system that worked well in vision and enlisting it higher-order cognition. Determined to construct a seamless story from jumpy input, for instance, patients with amnesia will, when asked what they did yesterday, construct a story out of memory scraps.

It isn't only amnesiacs whose brains confabulate. There is no good reason why dreams, which consolidate memories, should take a narrative form. If they're filing away memories, we should just experience memory fragments as each is processed. The cortex's narrative drive, however, doesn't turn off during sleep. Like an iPod turning on that cassette player, the fill-in-the-gaps that works so well for jumpy eye movements takes the raw material of memory and weaves it into a coherent, if bizarre, story. The reptilian brain lives on

I will be general. The reptilian brain is the most ancient of the brains. It has two hemispheres, just like the neocortex, and it may be that they relate functionally to the left and right hemispheres of the neocortex. The reptilian brain consists of the upper part of the spinal cord and the basal ganglia, the diencephalon, and parts of the midbrain—all of which sits atop the spinal column like a knob in the middle of our heads.

It is thought to represent a fundamental core of the nervous system and derives from a form of mammal-like reptile that once ranged widely over the world but disappeared during the Triassic period having provided the evolutionary link between dinosaurs and mammals. All modern mammals have this reptilian complex, including humans.

At least five human behaviors originate in the reptilian brain. These have been denoted as isopraxic, preservative, re-enactment, tropistic, and deceptive. Without defining them, I shall simply say that in human activities they find expression in:

1. obsessive-compulsive behavior
2. personal day-to-day rituals and superstitious acts
3. slavish conformance to old ways of doing things
4. ceremonial re-enactments
5. obeisance to precedent, as in legal, religious, cultural, and other matters responding to partial representations (coloration, "strangeness," etc.), whether alive or inanimate and all manner of deception.

Reptiles do not dream, but animals which have evolved from the reptiles (mammals & birds) do dream. Why? Because the reptilian mind is still operating in them and we humans call that mental state "dreaming." There is no "dreamstate" in reptiles because this mentality is their waking state. It is repressed during our waking hours (but still functioning it never sleeps) by chemicals released neocortically then the reptilian is allowed to function during sleep and dream, when the left hemisphere is in turn repressed. But obviously, the reptilian brain is not satisfied being relegated to the "nightwatch" of an inert body. It wants far more than that.

Humans invented rituals and ceremonies, and then, theater. Now where do you suppose those revelations came from? Theater, with its famous theorem of the "suspension of disbelief" (which is simply another way of saying, "Put your left brain to sleep.") is a re-invention of the reptilian mental-state "out-there". And of course, now we have excellent duplication of the reptilian mindset with movies and television, etc. which by some estimates, occupies up to 16-18 hours of our time per day, when you add in sleep-dream time.

A much detailed description of brain function by Mr Davidman can be found here.

<http://www.solhaam.org/articles/humind.html>

Overview of the brain

Brain Wave Entrainment Technology

The brain is probably the most complex structure in the known universe; complex enough to coordinate the fingers of a concert pianist or to create a three-dimensional landscape from light that falls on a two-dimensional retina. While it is the product of many millions of years of evolution, some of the structures unique to the human species have only appeared relatively recently.

For example, only 100,000 years ago, the ancestors of modern man had a brain weighing only about one pound - roughly a third of the weight of the current version. Most of this increased weight is associated with the most striking feature of the human brain - the cortex - the two roughly symmetrical, corrugated and folded hemispheres which sit astride the central core.

Almost all the tasks that seem hard or difficult for human beings but that the present generation of computers can easily perform are associated with processing in parts of the relatively new cortex. Conversely, tasks that humans normally find easy but that are difficult for computers typically have a much longer evolutionary history. Although playing chess, doing higher mathematics and troubleshooting electronic circuits may seem intellectually challenging for humans, current computers can cope very straightforwardly. However, a modern computer (even after much careful programming) is typically very poor at such simple tasks as sensing its environment or coordinating movements. A simple operation like recognizing someone's face, which we find rather straightforward, is a formidable problem for a computer. Indeed, a 2-year-old child will perform much better at these tasks! This observation is not so surprising, though, when one considers that the child is using multiple levels of processing that have evolved over many hundreds of thousands of years.

In evolutionary terms, all brains are extensions of the spinal cord. The distant ancestor of the human brain originated in the primordial seas some 500,000,000 years ago. Life and survival in those seas was relatively simple and in consequence these early brains consisted of just a few hundred nerve cells. As these initial sea-creatures evolved and became more complex, so too did the brain. A major change occurred when these early fish crawled out of the seas and onto the land. The enhanced difficulties of survival on land led to the creation of the "reptilian brain". This brain design is still visible in all modern reptiles and mammals and is a powerful clue to our common evolutionary ancestry.

The next major addition occurred with the mammalian brain in which a new structure emerged - the cerebrum or forebrain along with its covering, the cortex. By now, the brain consisted of literally hundreds of millions of nerve cells organized into separate regions of the brain and associated with different tasks. About 5,000,000 years ago, another type of cortex appeared in a new species - early man. In this brain, the surface of the cortex was organized into separate columnar regions less than one millimeter wide but each containing many millions of nerve cells or neurons. This new structure allowed much more complex processing to take place. Finally, about 100,000 years ago, this new cortex underwent rapid expansion with the advent of modern man. The present day cortex contains something like two-thirds of all neurons and weighs about three pounds - almost triple its weight only one hundred thousand years ago!

Thus the human brain consists of roughly three separate parts.



- *The first segment in the lower section, sometimes called the brain stem, consisting of structures such as the medulla (controlling breathing, heart rate and digestion) and the cerebellum (coordinating senses and muscle movement). Much of these features are inherited "as is" from the reptilian brain.*
- *The second segment appears as a slight swelling in lower vertebrates and enlarges in the higher primates and ourselves into the midbrain. The structures contained here link the lower brain stem to the thalamus (for information relay) and to the hypothalamus (which is instrumental in regulating drives and actions). The latter is part of the limbic system.*

The limbic system, essentially alike in all mammals, lies above the brain stem and under the cortex and consists of a number of interconnected structures. Researchers have linked these structures to hormones, drives, temperature control, emotion, and one part, the hippocampus to memory formation. Neurons affecting heart rate and respiration appear concentrated in the hypothalamus and direct most of the physiological changes that accompany strong emotion. Aggressive behavior is linked to the action of the amygdala, which lies next to the hippocampus. The latter plays a crucial role in processing various forms of information as part of our long term memory. Damage to the hippocampus will produce global retrograde amnesia, or the inability to lay down new stores of information.

As we have seen, much of the lower and mid brain are relatively simple systems which are capable of registering experiences and regulating behavior largely outside of any conscious awareness (we don't have to think to remember to breathe!). In a sense, the human brain is like an archeological site with the outer layer composed of the most recent brain structure, and the deeper layers consisting of structures from our shared evolutionary history with the reptiles and mammals.

- *Finally, the third section, the forebrain appears as a mere bump in the brain of the frog but balloons into the cerebrum of higher life forms and covers the brain stem like the head of a mushroom. It has further evolved in humans into the walnut-like configuration of left and right hemispheres. The highly convoluted surface of the hemispheres - the cortex - is about two millimeters thick and has a total surface area of about 1.5 square-meters (the size of a desktop).*

The structure of the cortex is extremely complicated. It is here that most of the "high-level" functions associated to the mind are implemented. Some of its regions are highly specialized - for example, the occipital lobes located near the rear of the brain are associated with the visual system. The motor cortex helps coordinate all voluntary muscle movements.

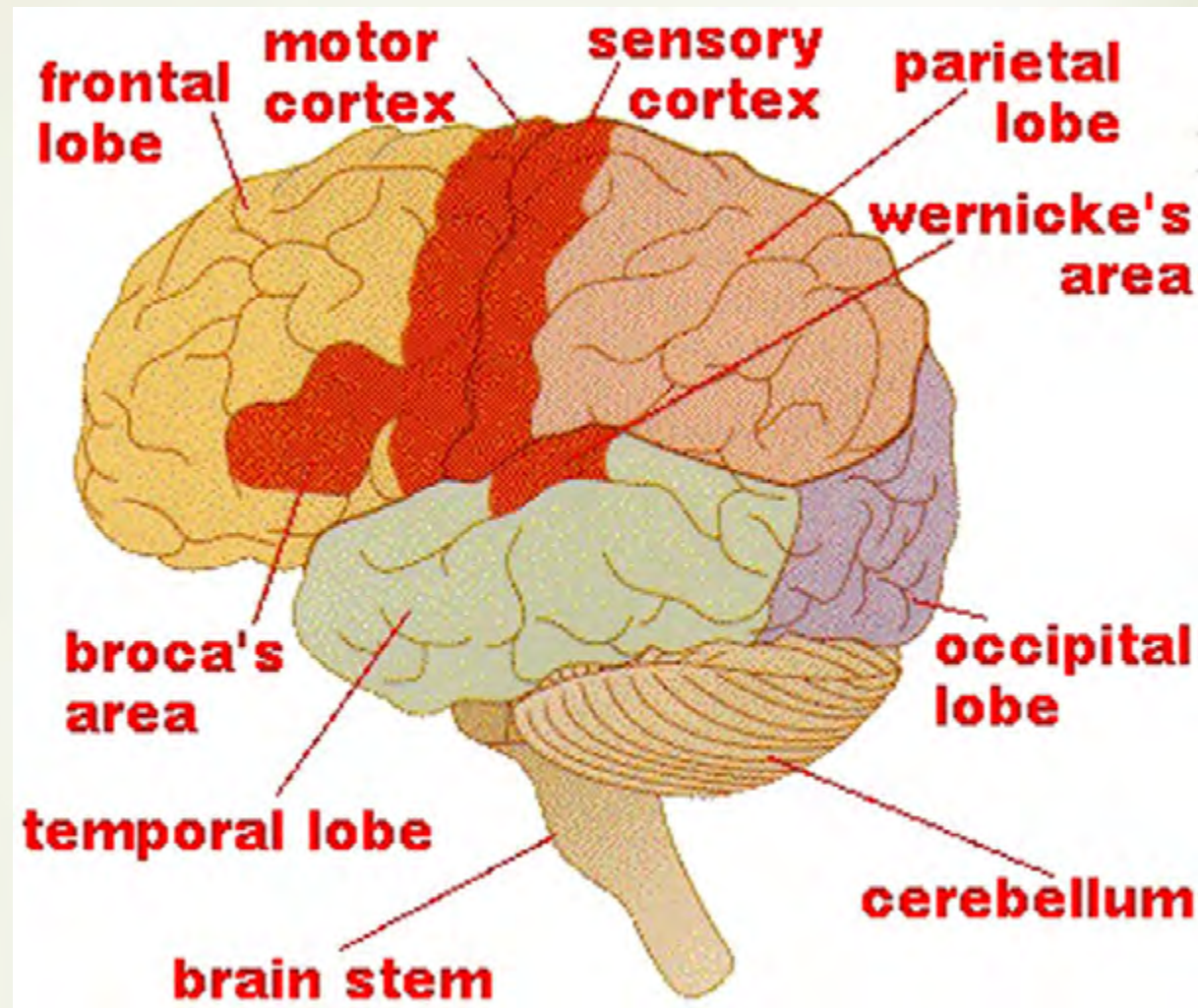

The parietal lobes positioned in an arch over the center of the cortex contain a detailed map of whole body surface.

More neurons may be dedicated to certain regions of the body than others - for example, the fingers have many more nerve endings than the toes. We can use this to construct a distorted map of the body which shows the emphasis given to certain regions of the body's surface.

There is an approximate symmetry between left and right hemispheres - for example, there are two occipital lobes, two parietal lobes and there are two frontal lobes.. However this symmetry is not exact - for example, the area associated with language appears only on the left hemisphere.

The frontal lobes occupy the front part of the brain behind the forehead and compose the portion of the brain most closely associated with "control" of responses to input from the rest of the system. They are most closely linked with making decisions and judgments.

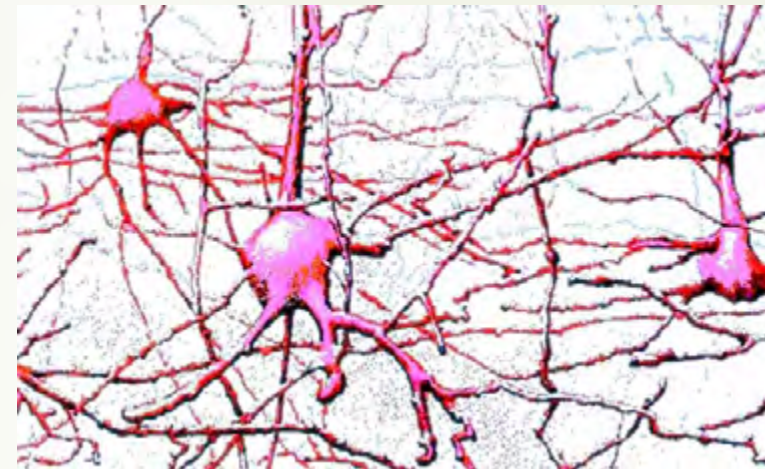

In most people, the left hemisphere is dominant over the right in deciding which response to make. Since the frontal lobes occupy 29 percent of the cortex in our species (as opposed to 3.5 percent in rats and 17 percent in chimpanzees), they are often regarded as an index of our evolutionary development. In individuals with normal hemispheric dominance, the left hemisphere, which manages the right side of the body, controls language and general cognitive functions. The right hemisphere, controlling the left half of the body, manages nonverbal processes, such as attention, pattern recognition, line orientation and the detection of complex auditory tones. Although the two hemispheres are in continual communication with each other, each acting as independent parallel processors with complementary functions, the dominant left-hemisphere appears most closely associated with a conscious self.

These structural features of the brain have been known for some time. In the section Brain components we will explore the nature of the cells themselves and later in Brain operation and processes try to understand how this set of intercommunicating complex structures we have described can possibly arise from the function and organization of the neurons themselves

One of the dilemma's of being human, with consequences at work and in our personal lives, is that the fabulous instinctual behaviors that protect us from physical dangers-- the fight, flight, freeze reactions rooted in the "reptilian" portion of the brain-- work against us in social relationships. Whatever your beliefs about the beginnings of human existence, you probably agree that humans have reactions to danger that don't require conscious thought. If we detect danger in the environment-- a snake, a violent person, a vehicle bearing down on us -- we act without thought (and hopefully take the right action).

Unfortunately, the same split-second reactions are frequently present in social relations, and are not nearly as useful as they are when handling physical danger.

For example, when an authority figure enters the room, the portion of your brain that scans the environment may send the danger signal to the reptilian brain, even if you get along relatively well with that person. For many people, it is hard to relate to their bosses without slipping into fight (which usually takes the form of "logically" disagreeing with whatever the boss or company says), flight (which is usually "escaping" into avoidance behavior-- not saying what you really think or not expressing how you really feel), or freeze behaviors (when a normally intelligent and engaging person goes "brain dead"). Once activated into fight or flight mode, it's easy to misunderstand. If I think I'm being attacked (and I

use the term "think" lightly here... as in my cognitive brain has scanned the environment and made a split second assessment, and my subsequent thoughts and feelings reflect that assessment), then it is likely, regardless of the other person's intentions, that I will view their words and actions in an unfavorable light, and as further proof of whatever beliefs I have formed about them.

Related Files



The Garden of Eden

208



Sumerian Gods Allegedly Create a Biogenetic Experiment



Dilmun, Iraq

209



All Seeing Eye

Isis, Iris, Pupil, Rods and Cones, Masonic Symbolism

210

SCIO
super learning...

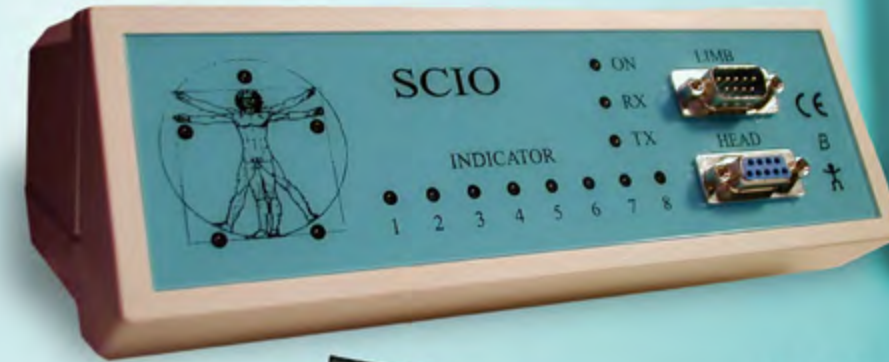

It is scientific fact that when a low level voltage and micro-current pulse is applied to the body osmosis, enzyme activity, and healing are increased. The SCIO will let the patient's body electric autofocus a harmonic pulse to maximize this effect. This current applied to the cranium has been shown to stimulate the learning process and increase memory retention, and learning. There is published research on these therapies. The new world of energetic medicine can help you to learn twice as much in half the time comfortably and easily.

If you need more information on the SCIO and purchase details please get in touch with us

Maitreya Kft.

tel: +3613036043 | web: www.qxsubspace.com | e-mail: info@qxsubspace.com

SUPER LEARNING

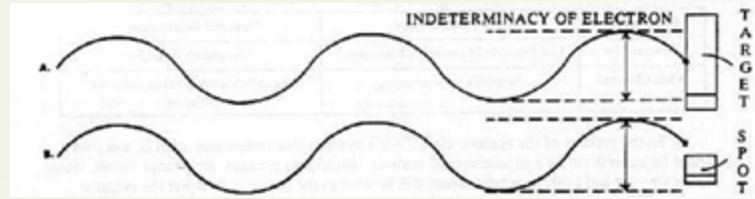

Caduceus Rod of Hermes, DNA

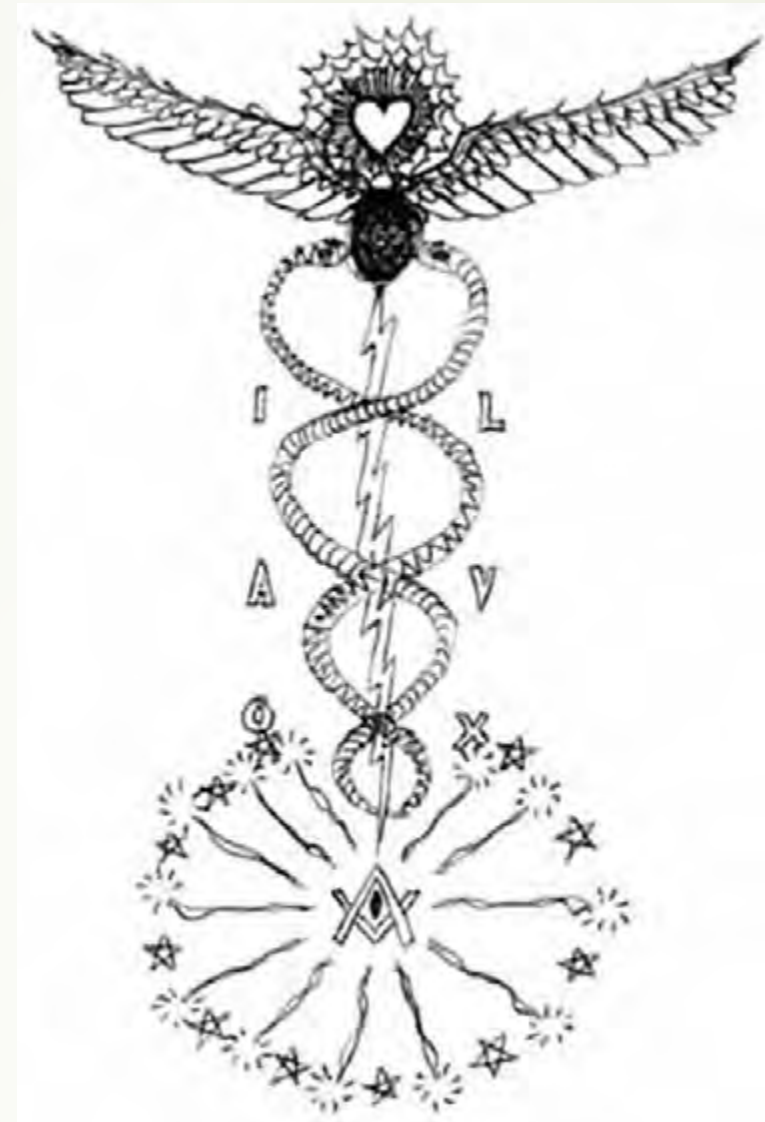

Alchemy

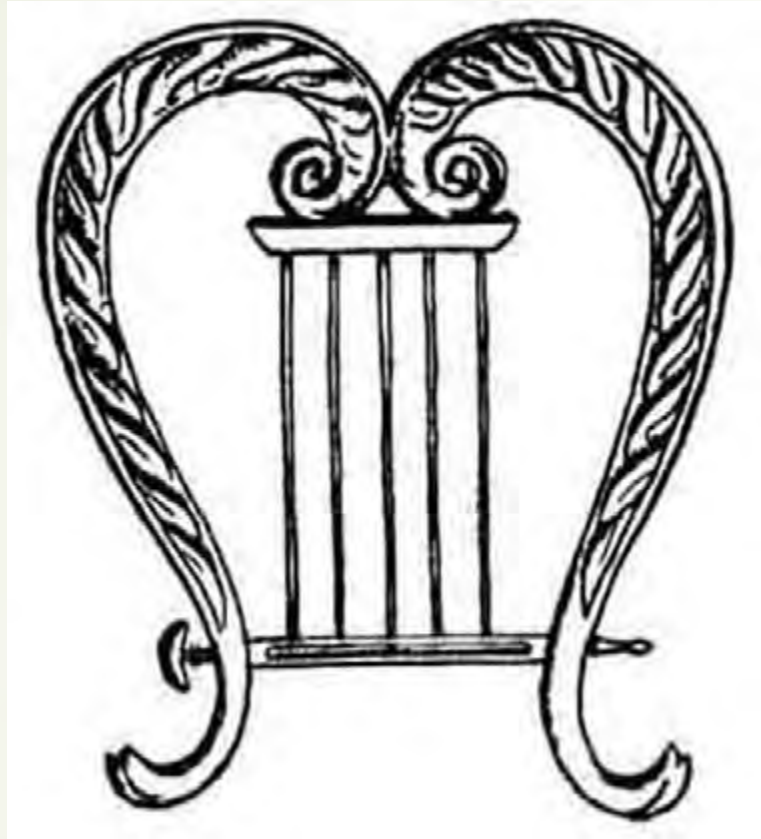

Lyra of Hermes

Using the Rod to Slay the Dragon



Omega Project, Ending the Human DNA Experiment, Leo, Lion



Ouroboros, 2012



Reptilian Connections



The Great Serpent Mound Creation



Coiling Snake, Dragons

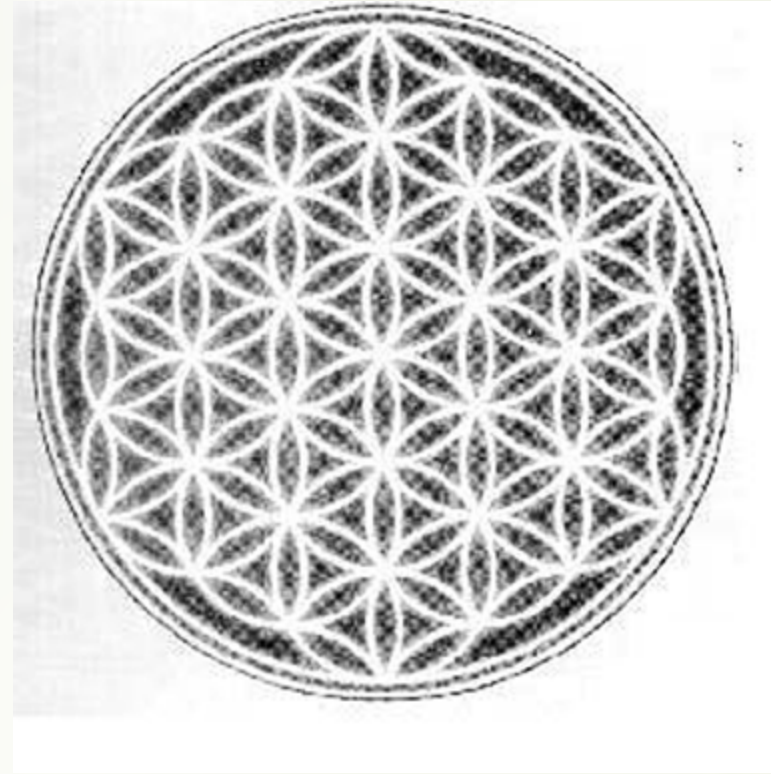

Kundalini

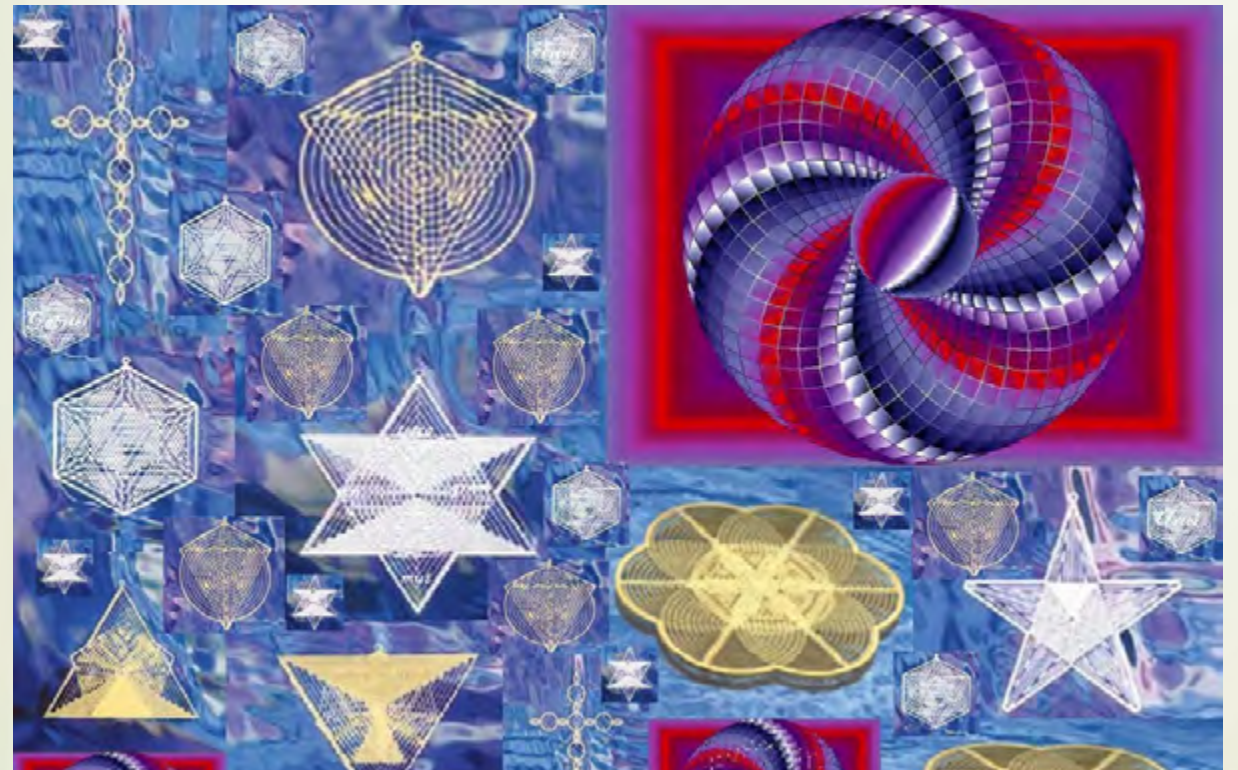

Uraeus, Egyptian Connections Alpha, Omega



Quetzalcoatl Feather Serpent God, 2012, Mayan Calendar

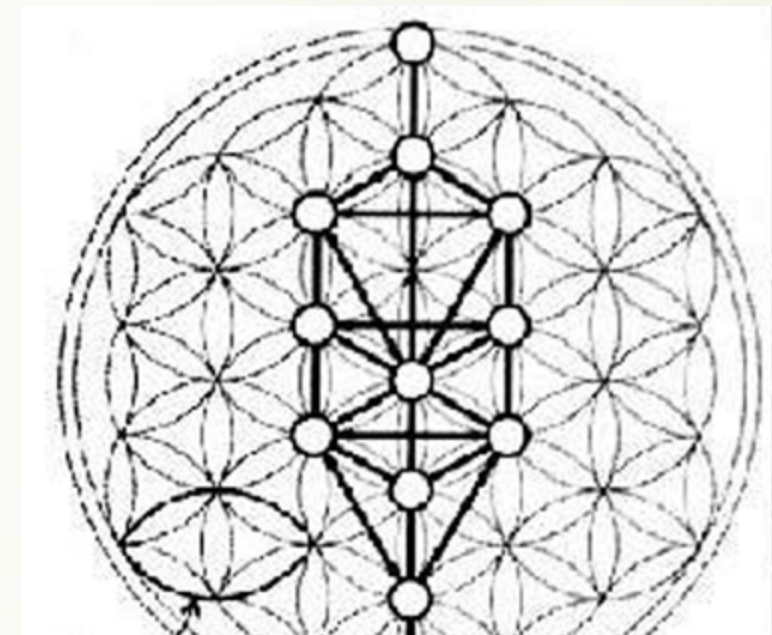
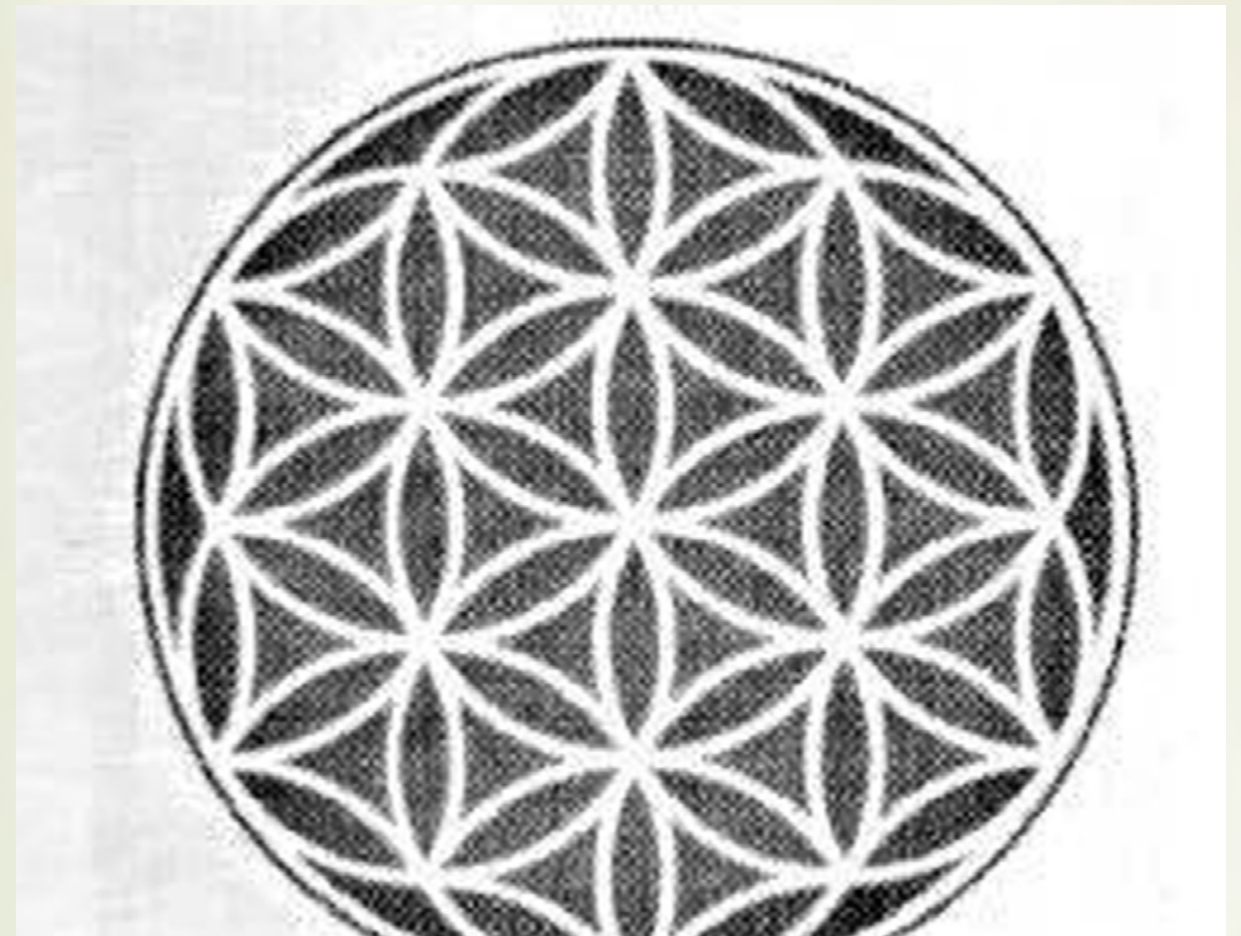

Dogon Nommo

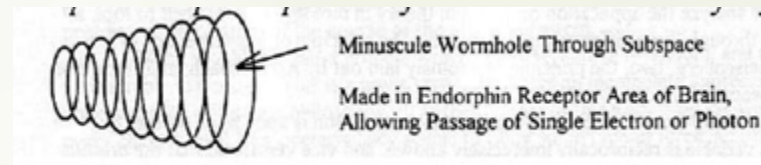
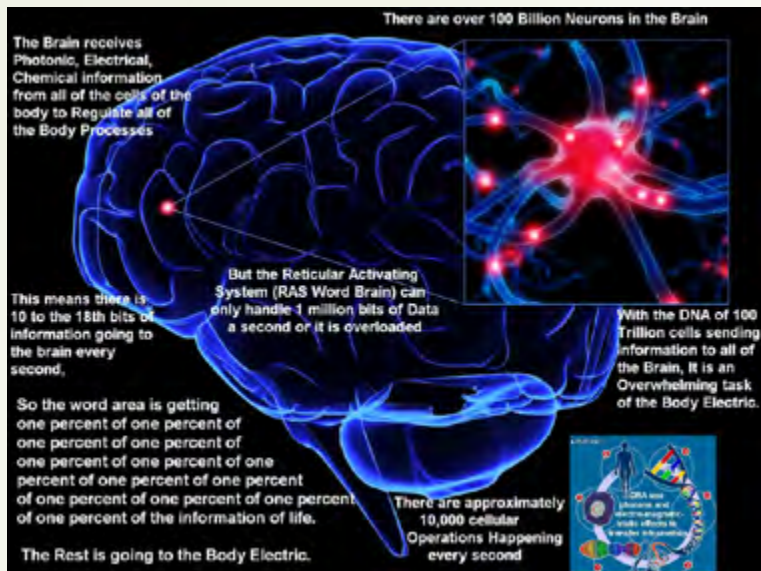

Gods with Water Buckets

Organization	Guided Indeterminacy	Unguided Indeterminacy
Governed by	Life Principle Organized Indeterminacy	Uncertainty Principle
Wise Observer	Approach to Observation	Approach to Observation (Mind of Observer)

Amphibious Gods

Oannes, Oneness, Babylon, Baby Lion, Many Others

Twin Flames Balance

Reunion of both aspects of your soul at Zero Point

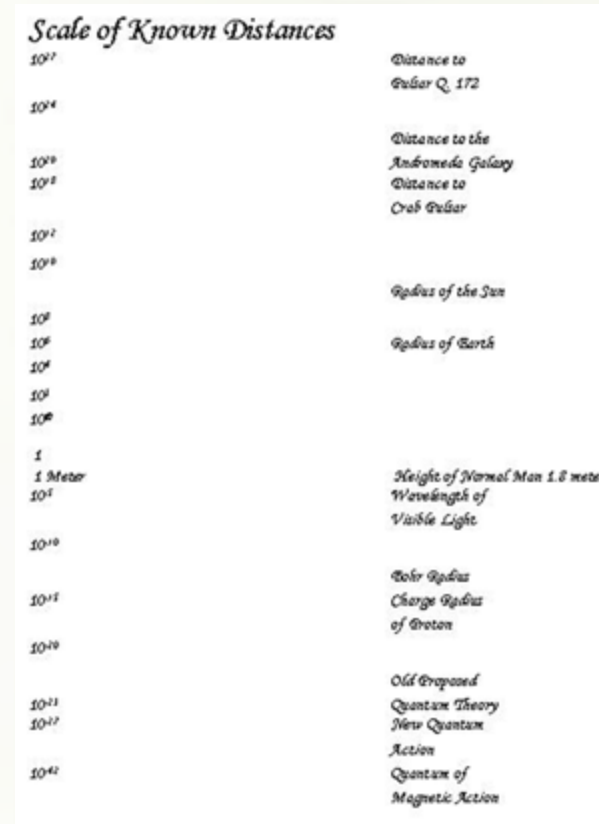

Zero Point

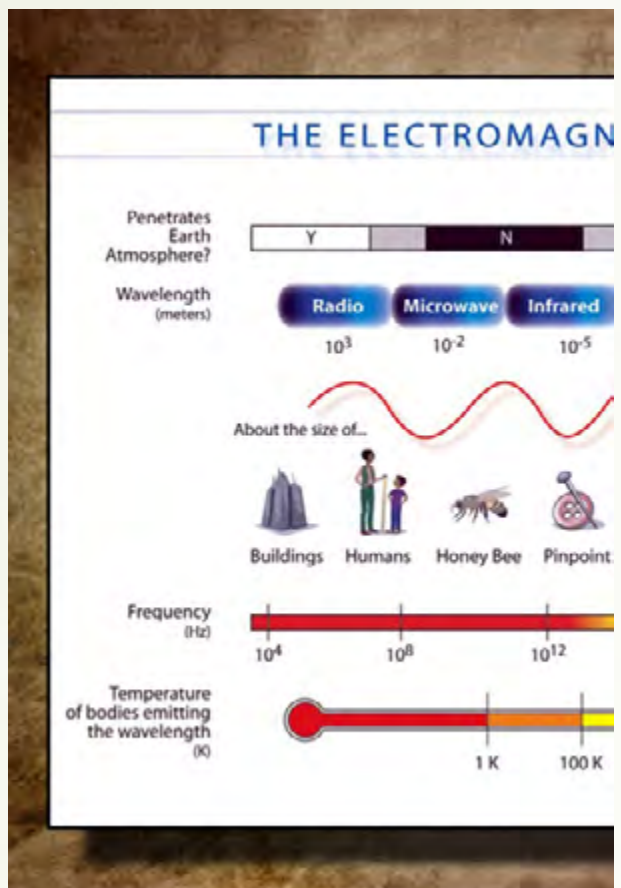

The Eclipse of Time and Consciousness

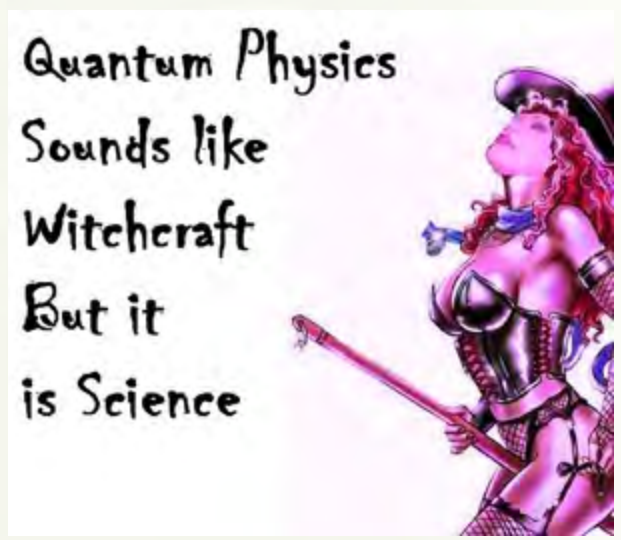

Merkabah

*Counter rotating fields - Rotation and Spin
Movement of consciousness between realities*

Center, Heart Chakra

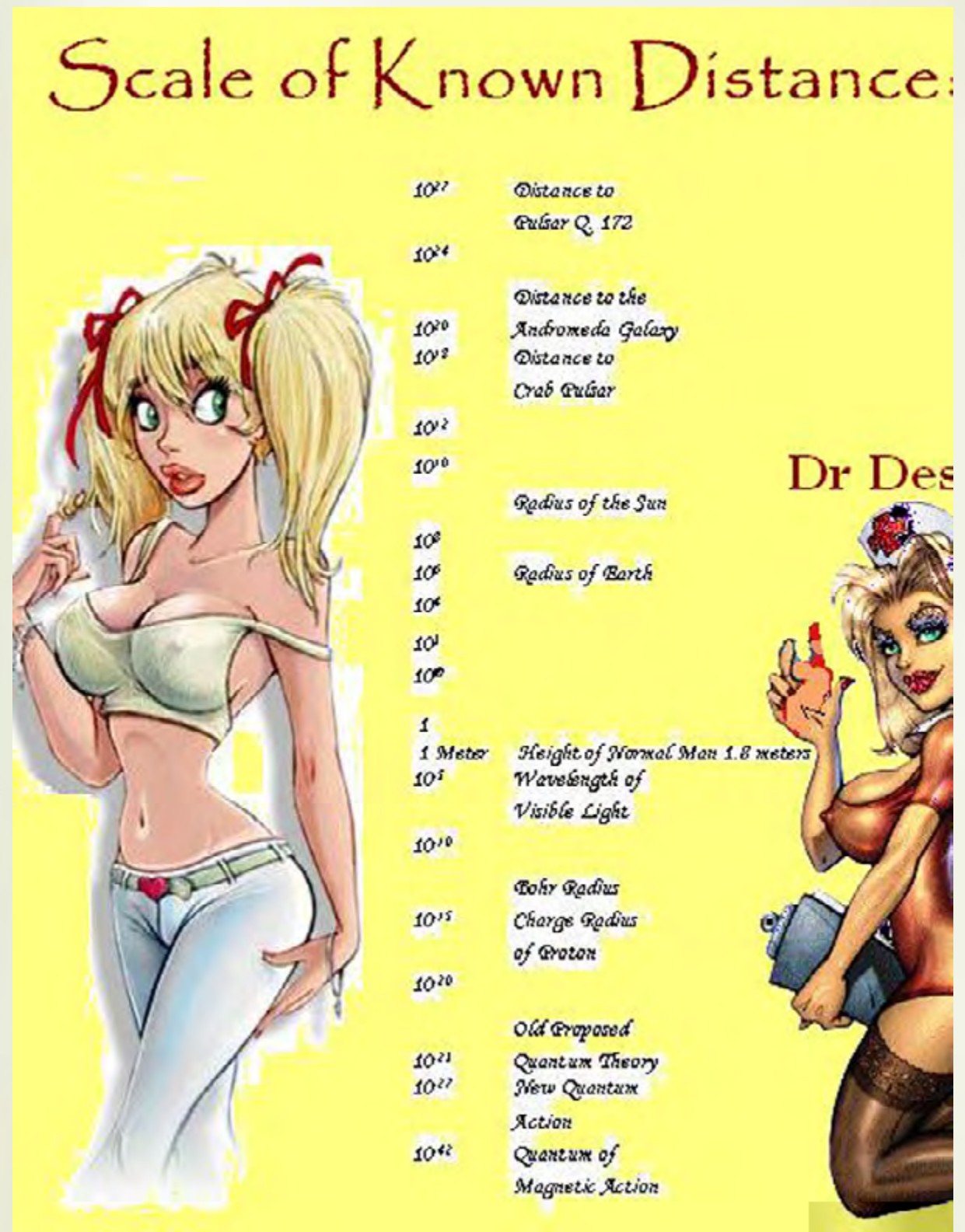

Hour Glass Effect - Time - Hours - Horus Rebirth

$$P = \frac{1}{\sqrt{2\pi}} e^{-x^2/2}$$

Log both s

$$L_n P = L_n \frac{1}{\sqrt{2\pi}} - \frac{x^2}{2}$$

$$L_n P = L_n \frac{1}{\sqrt{2\pi}}$$

$$2L_n \frac{1}{\sqrt{2\pi}} x^2$$

$$\frac{1}{n}$$

Standard Deviation =

Qabbalah - Flower of Life - Star of David

Above and Below

$$\Delta(1/n) = T \Delta n$$

The Court Jester and the Fleur de Lis (Flower of Life)

$$L_n P$$

$$L_n \frac{1}{\sqrt{2\pi}}$$

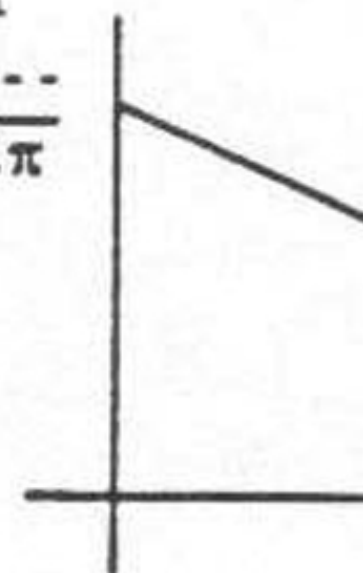

Hermes Trismegistus

The Emerald Tablets of Thoth (thought, consciousness) - As is Above, So is Below

Geometry

Dr Desire' Says that true Genius is just setting the Mind free to see

Sacred Geometry, Spiraling DNA, Golden Ratio, Fibonacci Numbers



12 Spiraling Cones Around 1 - Creation

The Scientific Results are in, the SCIO Works

Published in an ISSN Peer Reviewed Medical Journals

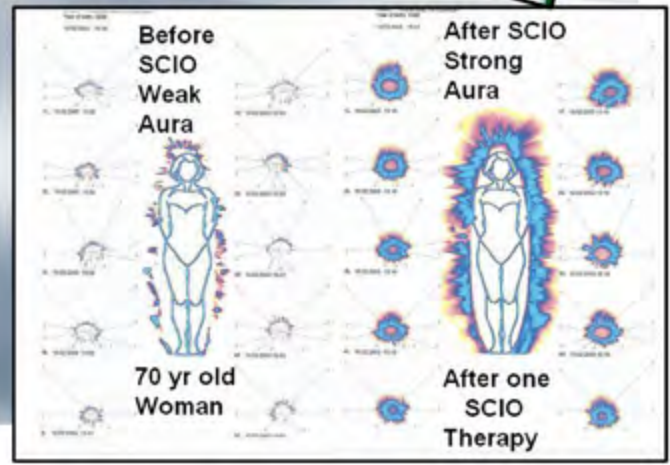
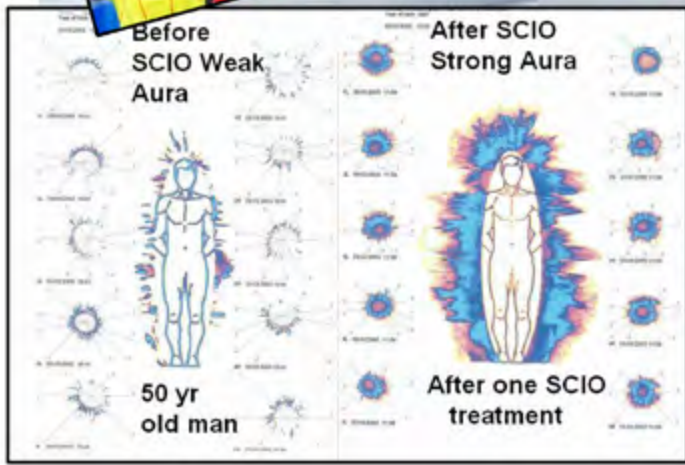
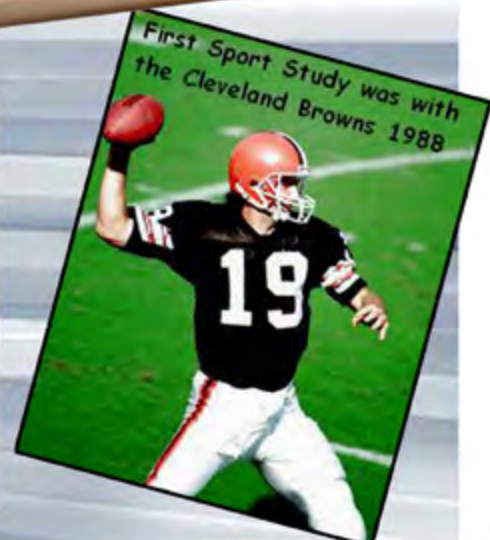

The SCIO will improve the body electric VARHOPE by five% as an average after just one session. The AutoFocusing Harmonic therapies of the Cybernetic Loop of measuring, stimulating, re-measuring, all guided at maximizing the body electric potential will improve your body electric by an average of five%. Improvements of Voltage, Amperage and thus power. Improvements of Resistance and Hydration that means improved enzyme and osmosis transfer of nutrients and detoxification. Improvements in Oxidation meaning more endurance. And improvement in Ph meaning more health. No wonder there are a mile long list of testimonials. Now we can understand why the sport athletes get such great results. A five% improvement is a great edge for a professional sportsman. The patented and proprietary process of the SCIO and QQC have been proven on the world scientific stage to work wonders of improving and stabilizing the body electric.

If you need more information on the SCIO and purchase details please get in touch with us

Maitreya Kft.

tel: +3613036043 | web: www.qxsubspace.com | e-mail: info@qxsubspace.com

<i>Work</i>	<i>Intensity Factor</i>	<i>Capacity Factor</i>
<i>Gravitation Mass</i>	<i>Height Distance</i>	<i>Mass</i>
<i>Electricity Charge</i>	<i>Voltage Amperage</i>	<i>Charge</i>
<i>Momentum Expansion Momentum</i>	<i>Pressure</i>	<i>Viscosity</i>
<i>Heat Photon</i>	<i>Temperature</i>	<i>Q/T</i>
<i>Subspace Polymorphic Influence over subtle</i>	<i>morphic resonance</i>	<i>influence</i>

Flower of Life

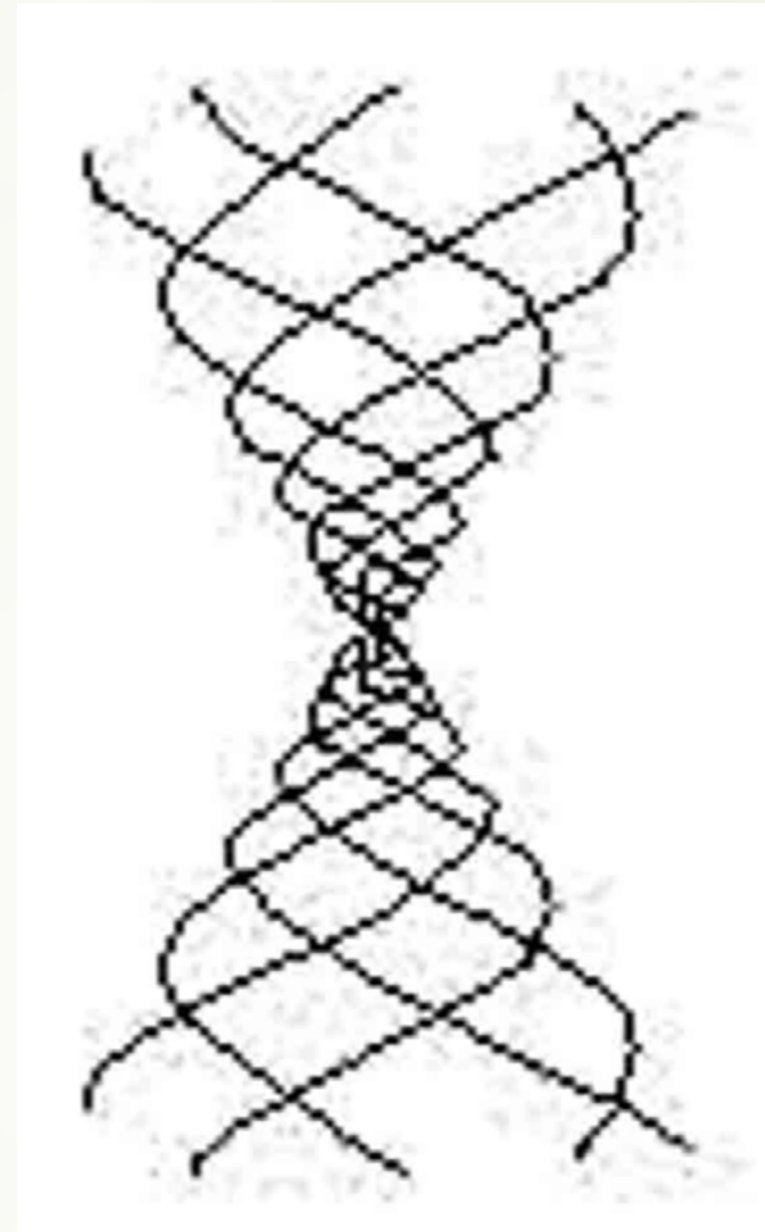

Tube Torus

<i>Information</i>	<i>DNA</i>	<i>HORMONAL</i>	<i>PHOTON</i>
<i>Mass</i>	<i>Momentum</i>	<i>Energy</i>	<i>Charge</i>
<i>MITOGENIC CODING</i>	<i>TRIPLET</i>	<i>IONIC</i>	<i>Transfer</i>
<i>BLOOD AND</i>	<i>LYMPHATIC</i>	<i>RADIATION</i>	
	<i>NEUROLOGICAL</i>		

Conical Hats



Metatron's Cube

Matter is Energy,
Our Bodies are made
of Energy Fields That
We can not Percieve
Some of these fields
have a spiritual
source that act
upon a person's
Soul. This Soul is
developed thru a
Process of Guided
Self Observations

However this is
rarely Achieved
due to man's
unique ability to
be Distracted
from Spirit
and Spiritual
Matters by
EveryDay
Trivia and
emotional
desires of

Greed, Anger,
Arrogance,
Defusion and
Conformity
Distract us
from Spirit

Desire

Archetypes

Law of Interpretation not Attraction

The Movie "The Secret" is wrong. You do not completely create the world or the events around you. You do completely control your interpretation of the world and the events around you.

It is not the Law of Attraction, it is an Effect of Attraction. It is a Law of Interpretation. There is the law of gravity. What goes up must come down, but there some few exemptions. This constitutes a law. It is seldom changed. The Law of Interpretation says that any verbal human will interpret what has happened to him based on his experiences, beliefs, and philosophies. He will always impose an attempt to explain what happens to him. Even "Shit Doth Happen" is an explanation.

In physics a weak force can affect things. We have the "observer effect" and the mind has been proven to be able to effect things. There is power in the human mind to affect objects. Telekinesis, remote viewing, Extra-Sensory Perception etc are all proven to be possible, but the effect is weak. But the effect is there. (see the "Proof" movie)

We can affect our lives and we have some very small control over objects, the world, and the events around us. But we have great and complete control over how we interpret the objects, the world, and the events around us.

All of the people in Hiroshima did not wake up that August morning and create the bomb, nor did they deserve it. All of them later interpreted the results. Most saw the bomb as a negative event. But some saw it as a growing event and a positive result. Nelson Mandela came out of jail after more than two decades and saw it as a positive thing. Some people can find the positive in the most horrendous events. We completely control the interpretation of the objects, the world, and the events around us. Some use negativity to describe the events, some use positivity but all interpret the events. All do this from within their own brains. The state of your brain determines the state of your interpretation of the world around you.

Some people are always happy and they learn to find the silver lining in every cloud. Some people are always dissatisfied and find fault in all around them. But all of us completely control the interpretation of the world around us. We do have some limited control of the world around us but we will never have complete control.

"The Secret" is wrong, in that you cannot just sit at home and think of things and bring them into your life. "The Secret" is right that you can affect your life positively and you can dramatically increase your chances of getting what you want. If you want to get a job you must fill out an application or two.

People think there is a law of attraction, but it does not hold out as a way to predict things. If it were a law then we could predict things. Example: if someone throws a rock off of a building and there is a crowd below, someone in the crowd will get hit by the rock. Now we might say the bad guy got it because he deserved it. The good guy got it because he was too good. The sad guy got it because he was negative and he brought it to him. The happy guy got it because he needed to learn a lesson. But in truth we do not know who gets it before it is done.



*The
Main
Fact of
Life is*

*You Do NOT
Create the
World or the
Events Around
You*

*But
You Do Control
Completely Your
Interpretation of
the World and
Events Around
You*

If there were a law we could predict the outcome easily. We could put a crowd in place and let one guy focus on wanting the rock to hit him and he does chants of mantras I want the rock. The rest of the people do chants of protection and affirmations that they are protected from rocks. We throw the rock and no matter how powerful the meditations we just don't know who will get it till after it hits.

After it hits we then are always able to explain it. We say the bad guy got it because he deserved it. The good guy got it because he was too good. The sad guy got it because he was negative and he brought it to him. The happy guy got it because he needed to learn a lesson. The human mind can interpret things very well after the fact. President Gerald Ford said that Hind Sight is 20/20. But Fore Sight is just probability theory. The law of interpretation holds fast.

When President Harry Truman dropped two bombs on non-military target cities of women and children, there was so much radioactive fallout thrown into the air. If one of these alpha ray or beta ray fallout products were to be ingested or breathed in the person would get cancer and die. There was such an increase in cancer in America after the three atmospheric detonations of atomic weapons of mass destruction that the world had to declare atmospheric atomic detonation illegal. Harry S. Truman killed more Americans with fallout over the next fifteen years than he killed Japanese on that day. Here once again people interpret his actions based on their own perceptions. In some minds he was a hero, in another mind he is a War Crime criminal. But I feel if more people knew what happened there would be more people thinking the later. (see the movie "War Crimes Trail of Harry S Truman")

Now who got the radioactive fallout, the good, the bad, the ugly, the deserving? The answer is we cannot predict, but we can always explain. Whatever happens people will step forward and explain why. You do not completely create the world or the events around you. You do completely control your interpretation of the world and the events around you. Your mind interprets what is around you.

In sports we can analyze, study and examine the details of the two teams competing. If there was a law of attraction we could always or at least generally predict a winner from who attracts it the most. But this is not the case. We must play the game. And no one knows the outcome. But after the outcome everyone steps forward with an explanation. Your mind has a weak power to affect your surrounding but a strong firm power to interpret events after they are completed.

The condition of your mind, spirit and soul determines how you perceive the world around you.

God and The Cosmos

I believe firmly in a God that does guide all of us for growth and spiritual development. This allows for karma as well. The theory of the big bang states that all of the energy in the universe or at least a big chunk of it came through a singularity in one to the minus forty third of a second. Matter will later evolve from condensation of this energy. This means that all things all particles have a quantum entwined history. Particles of quantum energy that were once entwined can communicate with each other as in Bell's theorem. The PEAR project proved that there was a connectivity of things and that the human mind a known quantum engine could communicate with things. There is a God consciousness of the universe. This God consciousness determines who gets the radioactive particle.

We have a part of the God consciousness in us. But just because a drop of water has the same characteristics as the ocean the drop should not think it is the ocean. We have some small part of this power in us but we need to be humble.

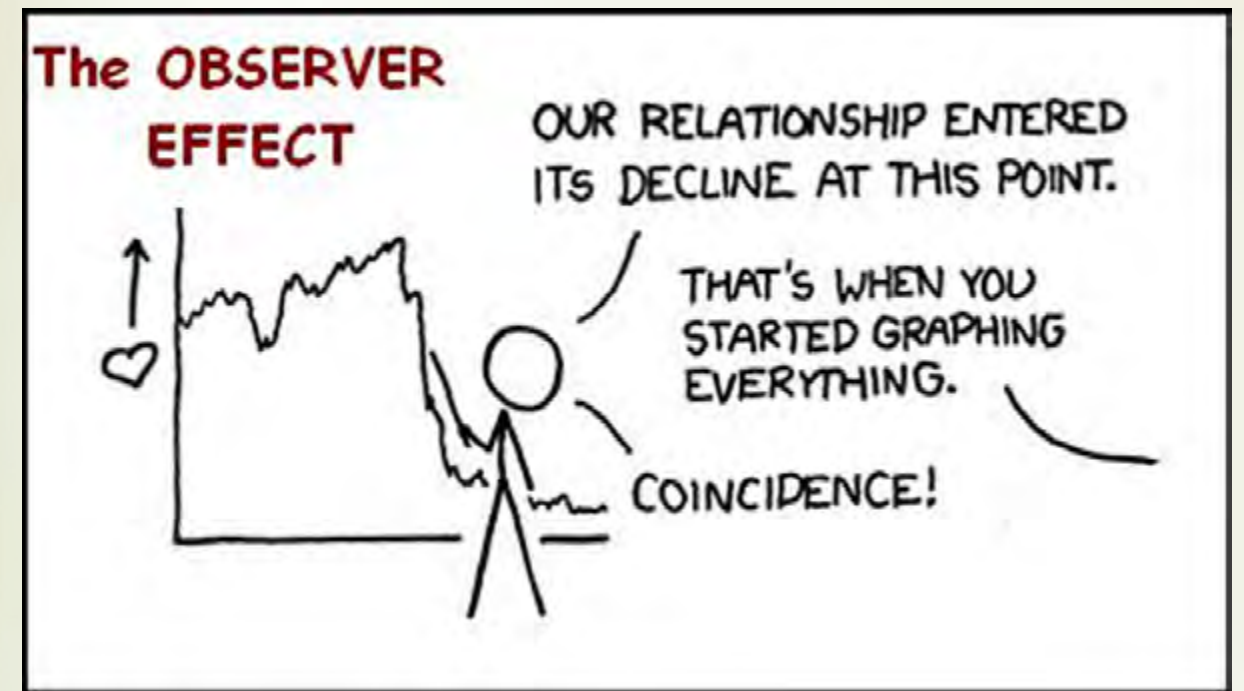

So the message to the "What the Beep" people is firmly you can affect your world slightly. God controls your world completely. We need to have humility. You need to act not just think. And you do control your interpretation of the events completely.

And people will interpret their reality as they see fit, and often this means they will adjust their interpretation to fit their belief system. I have seen scientist observe undeniable data on UFO, the powers of the mind, psychic phenomena, Ghosts etc and after seeing irrefutable evidence they adapt an interpretation to fit their dogma. It is difficult for people to face their disbeliefs.

We don't create the world around us we interpret how we see it.

They say there is always a quote "RATIONAL EXPLANATION". Of course the rational human mind after the fact can always make a rational explanation. This does not mean it is true but they must do it to preserve their belief system. Any rational explanation will do to allow them to drop pursuit into paranormal. For maintain a false belief is more important than truth.

Science has lost itself into a search for funding and in saving face. It ignores many obvious truths that should get more consideration and Rational explanations are easily accepted for too many phenomena that should be explored. Rationality and Rational explanations becomes a religion to these people who rationally reject religion.

The human mind must try to preserve its integrity. Everything we do has error built in. some would say that this alones guarantees the uncertainty problem. But this alone would imply that technology might solve the problem with less error. But in fact indeterminacy goes beyond error and extends to all things

at the core of existence.

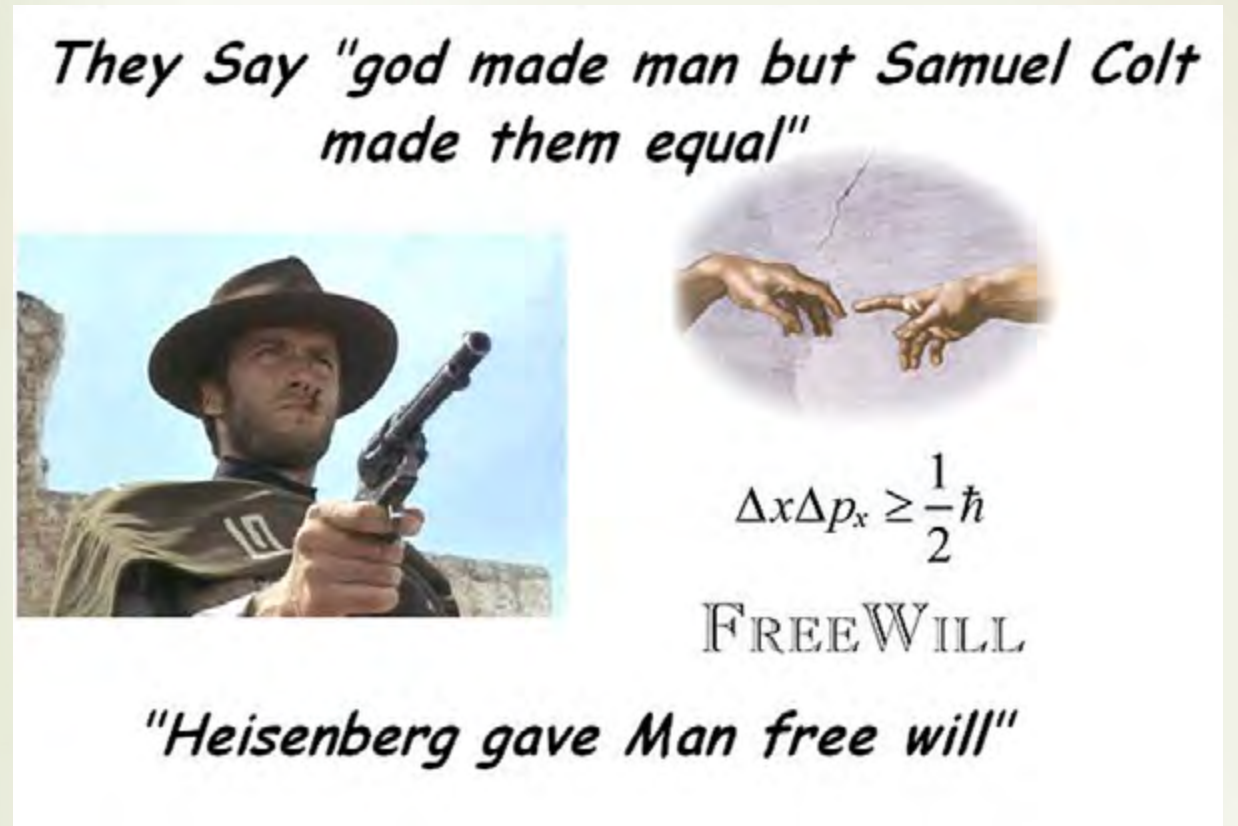
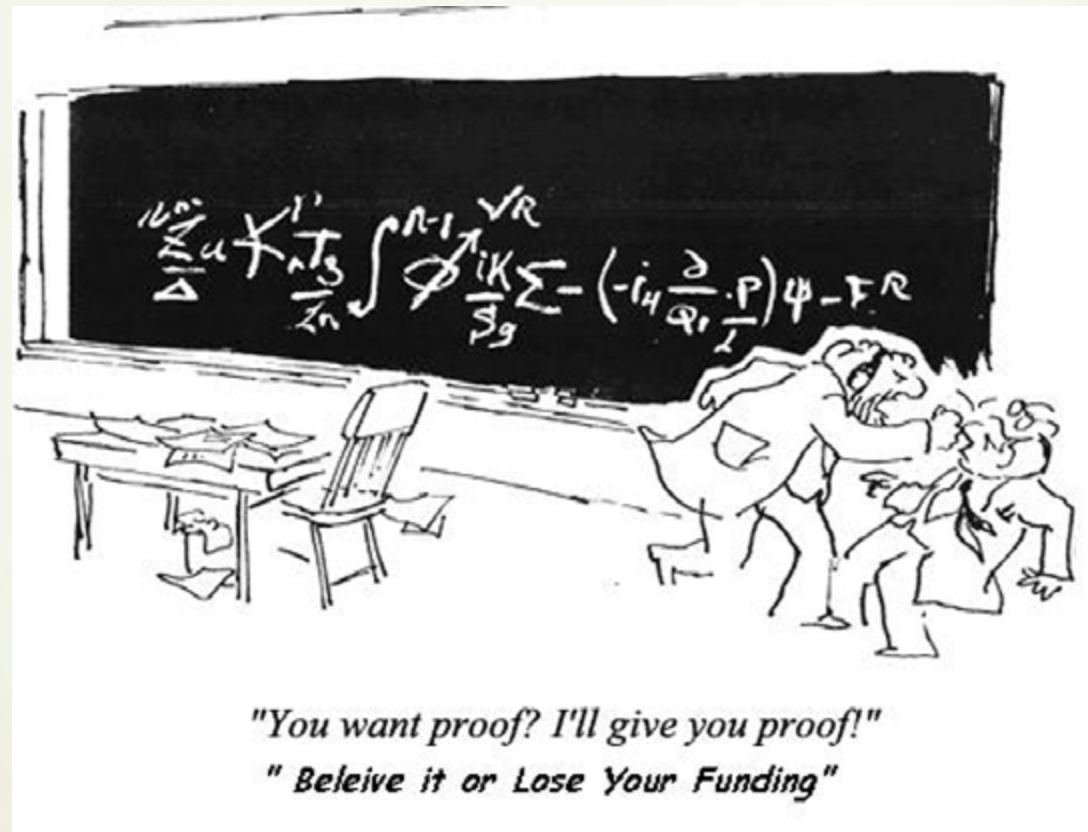

The World we Live in Has Indeterminacy built into it



There is Error in all things but the Indeterminacy Principle goes beyond Error the basic core of all existence is indeterminant



Even when we know the way things should turn out we must Play the Game, Because we just don't know, in life things have a degree of indeterminacy built in, and sometimes "Shit Happens", Owen's Law



You Can Take the Indeterminacy principle too far. Even though it is true and we do have Free Will. We must act on what we know and try to act on our predictions of outcomes. We need to play the game of life as best we can. And see where the outcomes lead us.

We need to find a balance of rationality and indeterminacy. The Yin versus Yang. There is a need for rational logical linear thought as in Western philosophy, but it is not the only path to knowledge. The Eastern ways have more of the other side of the brain working finding dreams, art, beauty, intuition. There is a male and female mind, a left and right hemisphere, a dreamer and doer, a 'see'-er and a 'be'-er, a watcher and a player, an active agent and a passive one all in each of us and many more. As we learn about the differences and the polarities we learn about ourselves. We learn to be the best we can and how to face life when 'Shit Happens'.

The best doctor is the doctor within. The best teacher is the teacher within. When you discover this and you activate it with modesty and humility recognizing what you don't know is always greater than what you know, life is much better. You can do anything it is just a matter of time.

$\Delta x \Delta p \geq \frac{\hbar}{2}$

OH ALICE, YOU'RE THE ONE FOR ME

BUT BOB... IN A QUANTUM WORLD HOW CAN WE BE SURE?

You can take the Indeterminacy Principle too far



Call for papers



Call for Papers

for the International Journal of the Medical Science of Homeopathy

The International Medical University of Natural Education IMUNE who sponsors the International Journal of the Medical Science of Homeopathy and Natural Medicine wishes to announce a call for papers. Please send us studies, letters, comments, articles, photos, testimonials, or stories for us to consider for publication.

Please send us in acceptable form to:

taflan_andreea@imune.net

Laws Versus Rules

You can call me anything except late for dinner

But if people respect personal freedom they will call me my chosen name Desiré.

Some people are more caught up in the way something looks rather than it's true nature and some people have limited minds but if you are true to truth, and you respect freedom over conformity then You can call me Desiré. I am deeply respectful of the law, in that way I am very very conservative.

But I am very suspicious and not respectful of rules. There is a law in South Carolina that says a person labeled male on his birth certificate cannot openly dress as a female. So I won't visit South Carolina. For the rest of America this is a rule not a law. I do not respect the rules of conformity. I do not respect the rules of convention or tradition. I challenge them with one word freedom. Small petty minds try to take away freedom and prefer tradition.

Once a FDA agent came into my office in Denver Colorado and he demanded we close up the shop because he said homeopathy was illegal. It was a rule he said. I took him into the office and showed him the FDA law. The FDA was founded by a homeopath. Homeopathy appears three times in the first three pages. He apologized and left.

You see the law is how we run our society. And our society makes and assumes rules. Many governmental people do not know the difference. They even think a rule is sometimes a law. But the law is always written on paper and can be read and enforced. Still there are times we need courts to decide when police or enforcement people have differing opinions than the public. Such was the case in 1996, when the FDA had a rule to ban acupuncture. The FDA thought that this was a law. I challenged this rule. And I won acupuncture became a real medical art in March 1996 because of me. I used the law to change the rule.

Right now many people thing that energetic medicine is illegal. This is a rule not a law, and I fight to defeat this rule and preserve the law. The law allows energetic medicine today. I am sure that we will need to go to a judge to decide this someday.

I do not break laws. I work diligently to obey laws. The FDA has broken the law in their vendetta against me and One day I will prove that. I left America in March right after Judge Matsch made the FDA and the Prosecutor dismiss the case against me on leap day 1996. The FDA went to Washington in June 1996 and tricked a Grand Jury into illegally making a bogus indictment against me. There was no charge against me when I left. So I did not flee, nor am I a fugitive.

I am a concerned citizen who is waiting for an American judge to rule on the validity of my case before I return. I have obeyed every law and always do. But everyone has denied me a judge to rule on the validity of the indictment against me. I have been warned of a conspiracy against me to have me put away without the chance of seeing a judge how could free me like the last one did.

I do not respect nor do I feel obligated to obey rules. Salesmen think that it is a rule they should wear a suit. I tried to tell them that most everyone knows to never trust a suit. But he is caught between people who are confused by rules and think their rules are law.

I have changed my name and sex rating in America. There are three American ID papers used, Passport,

Driver's License, and Voter's registration. My medical papers say I am both sexes and can chose which one I want. My only driver's license from Kentucky lists me as Desiré Dubounet and female. My voter's registration in Colorado is as Desiré Dubounet and lists me as female as well. So by American law I am Desiré Dubounet and female. This is the law, but for some this voids a rule. For some rules are more important than laws. It is a pity. For me law is more important than rules.



My name is legally in America, Europe, Africa, and around the world is Desiré Billie Dubounet

I studied the Buddhist way and that the cause of all suffering is Desire. To stop suffering you must control Desire. This was my doctoral thesis, in New Orleans. So when I choose my female name I choose Desiré to always remind me that desire has to be controlled. It can be expressed but controlled.

When Dustin Hoffman first became Tootsie in the movie he was in the Russian Tea Room in NY and he ordered a Dubonnet with a Twist, I said well I my life has now a twist.

But Dubonnet is the drink, Dubounet in French is a beautiful sexy bonnet worn by the most elegant of women. I am an elegant woman. Dubounet rhymed with Desiré so I choose my name.

For my middle name I choose Delicious, in my stand up comedy I say that

"Delicious is my middle name. It is not my whole name. It is the name of my hole." Ta Da drum role

By American law of the 14th amendment you can change your name by yourself in most states (not in California, but yes in Colorado) but the law says you cannot use trivial sexy terms and the specifically use the word "Delicious" as an example of words you can't use. So I cannot make my middle name Delicious.

When my father was born at first they thought the child was female, same with me. So the name on his birth certificate is Billie. The female spelling not Billy the male spelling. One week later my father's penis popped out and then on the birth certificate you can see where they erased female and changed it to male but they did not change the spelling of his name.

So my dad went thru life with a female name and he was tortured and troubled by the sex identity crisis with his hermaphrodite heart. He was bitter, mean, fearful, nasty and cruel and he hated almost everybody. He was abusive and brutal to my mother. But he was my dad and to honor him I took the middle name Billie. This reminds me of how a person can twist their soul, mind and those around him when they have to suppress and repress their inner feelings. It reminds me to love the sinner and hate the sin. It reminds me that to suppress a truth is to give it power over you.

For me to have the courage, the fortitude, the power of mind to be me what I am and not what others want me to be. It takes extreme power of personality and intellect.



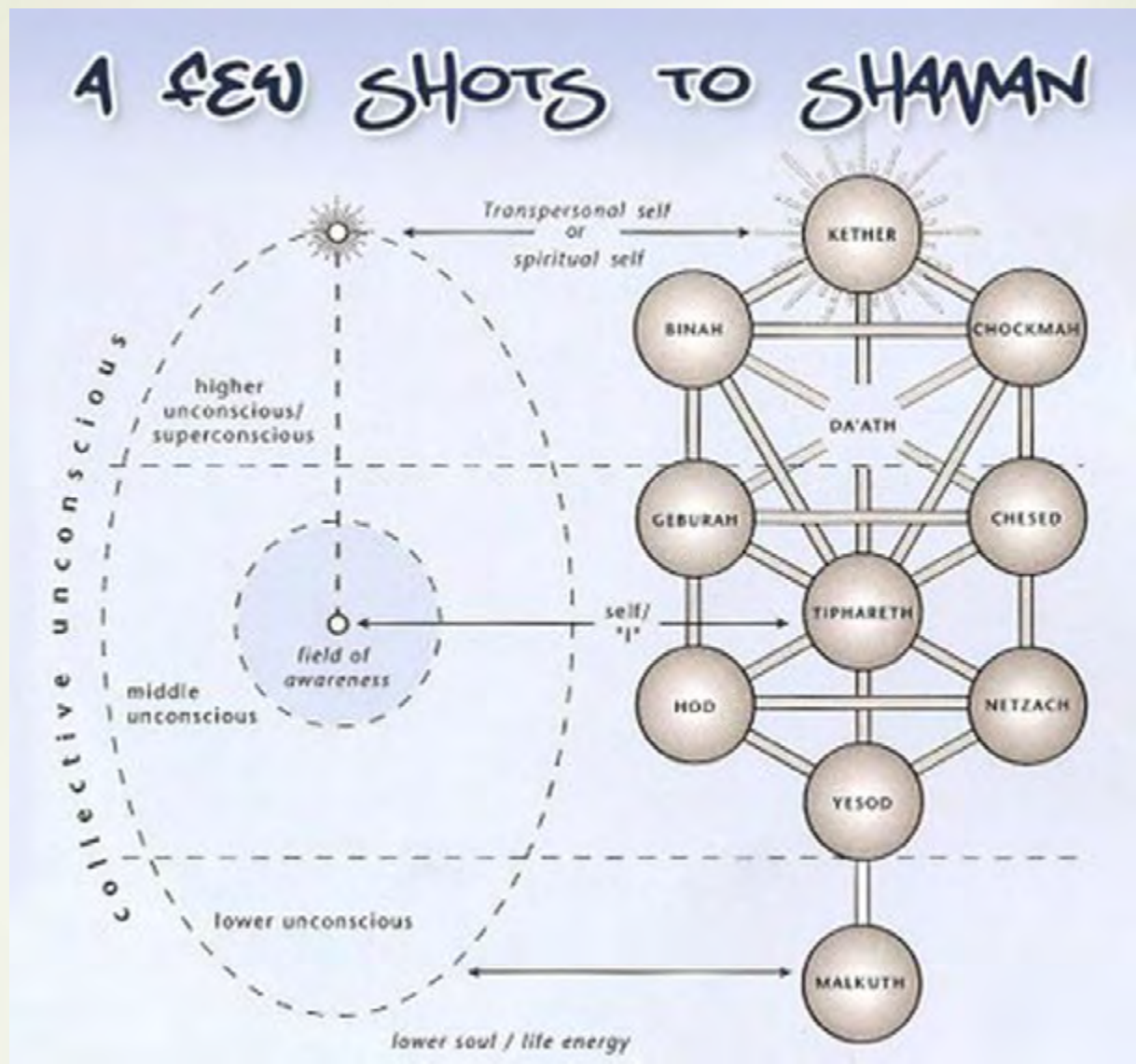

Simple Truths

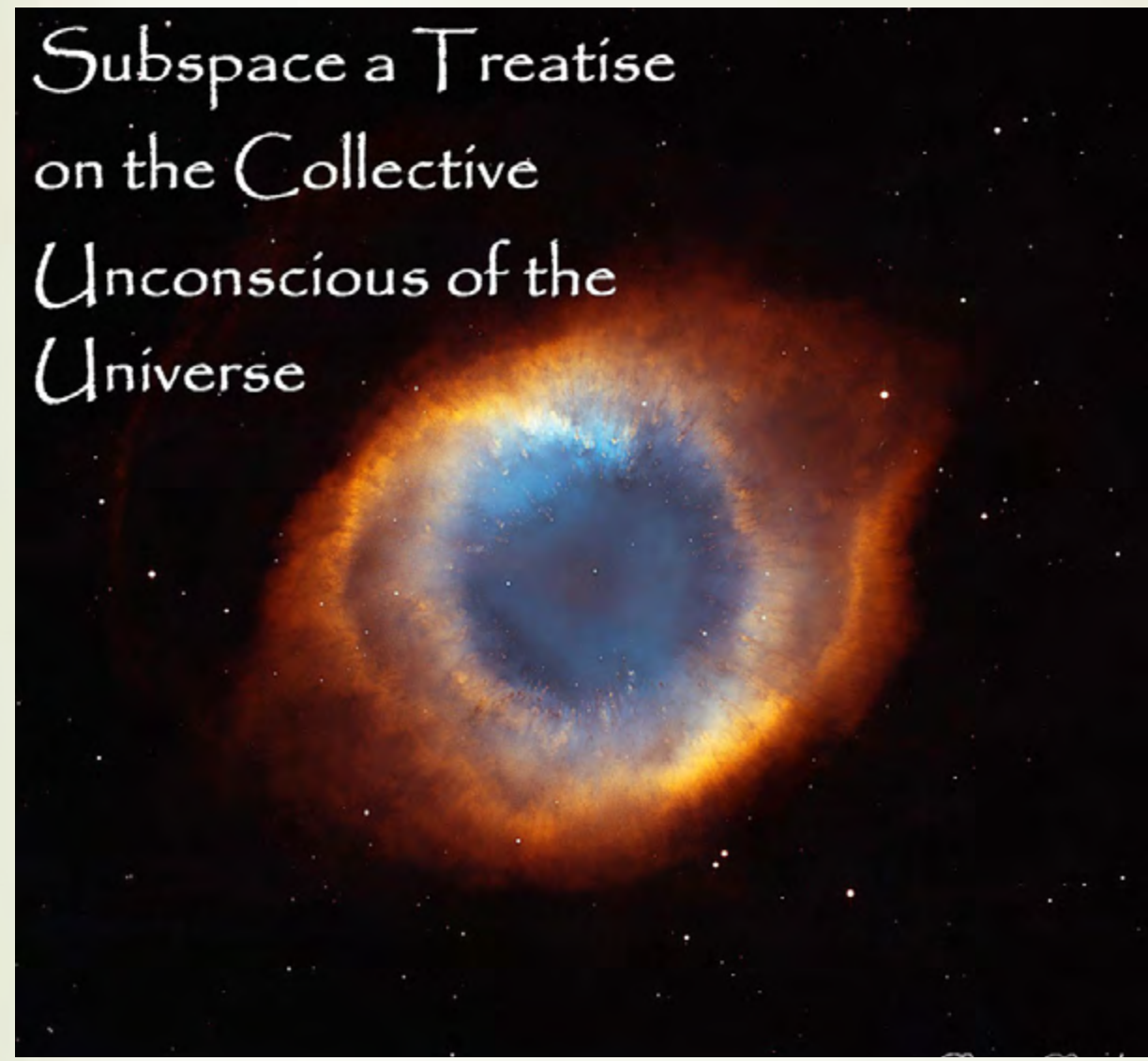

BUT STILL ALL ONE AT ONE LEVEL OF PERCEPTION

STILL ALL ONE THING IN SUBSPACE CONNECTION

The birth of the universe was what scientists call a big bang. The whole universe exploded thru a singularity in 10 to the -43 of a sec. So, at one time all things were exactly intimately one. According to our highest science of today, Quantum Electro Dynamics, when things were once so connected they will share some quantum connection and be entwined forever. If Twin photons are separated by great distance; and when we tell one photon something the other on knows it instantly even at the opposite ends of the Universe. This means that there is a subspace connection of all things.

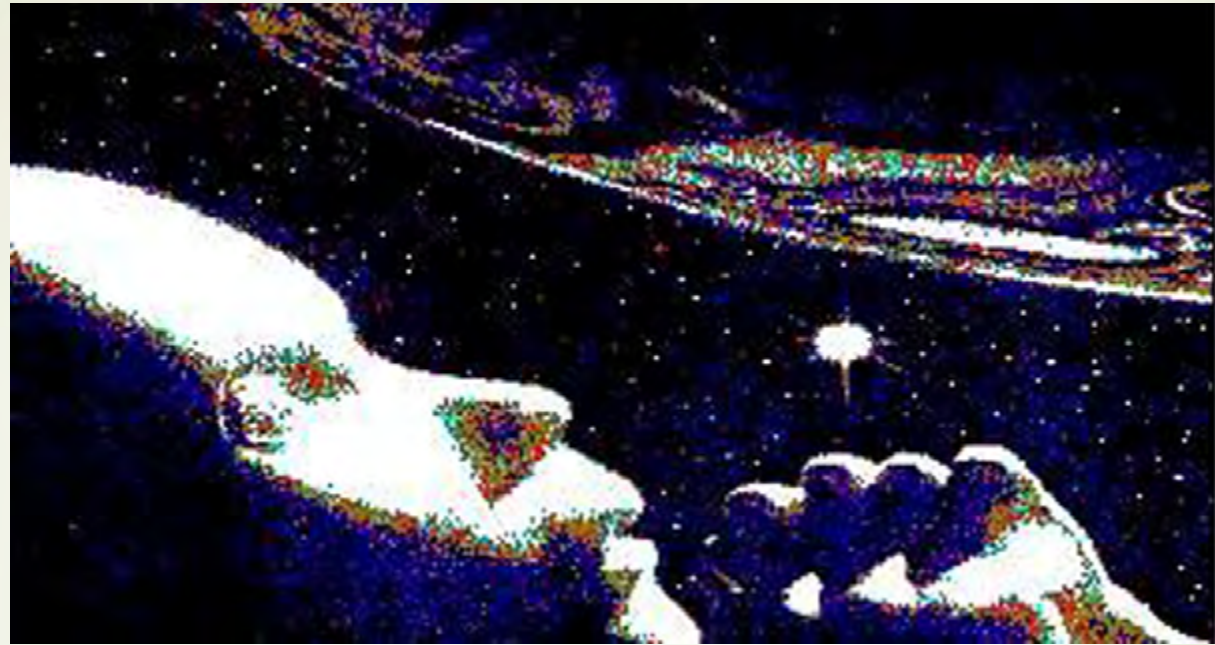

is still mathematically one thing.

So there is a God consciousness of the universe. And we all are connected because we all have some of that God consciousness in us. But just because a drop of water and the ocean have mutual characteristics, it is wrong for the drop to think it is the ocean.

Any fool can make things bigger, more complex, and more violent. It takes a touch of genius—and a lot of courage—to move in the opposite direction.

"it is an illusion we are separate. All things are one. Our task must be to free ourselves by widening our circle of compassion to embrace all living creatures and the whole of nature and its beauty"

$$E=mc^2$$



When we all think alike,
no one thinks very much.
- albert einstein

Carl Jung called it the collective unconsciousness. Einstein said "it is an illusion we are separate. All things are one. It is our job as humans to widen our circle of compassion to include all things." Scientists have proposed 11 dimensions and I have finished the calculation to propose the 12th dimension which I call Subspace. Subspace is connection of all things from a mathematical perspective where the universe

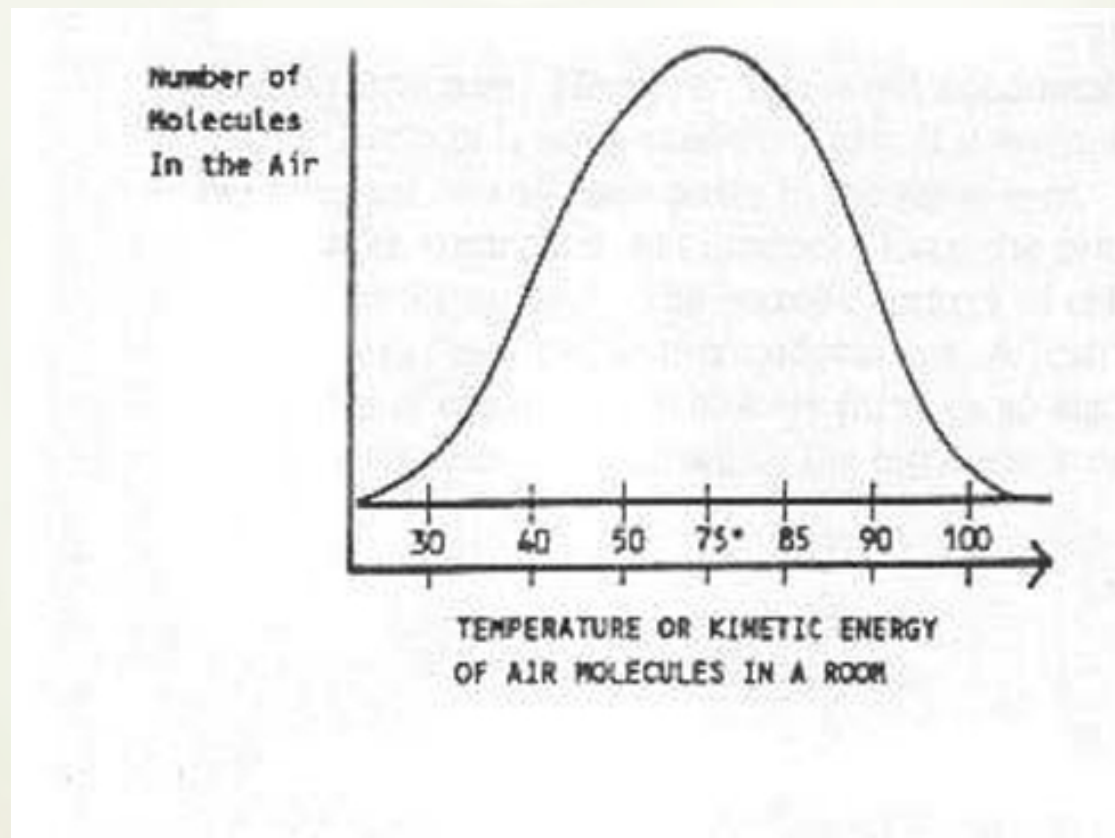
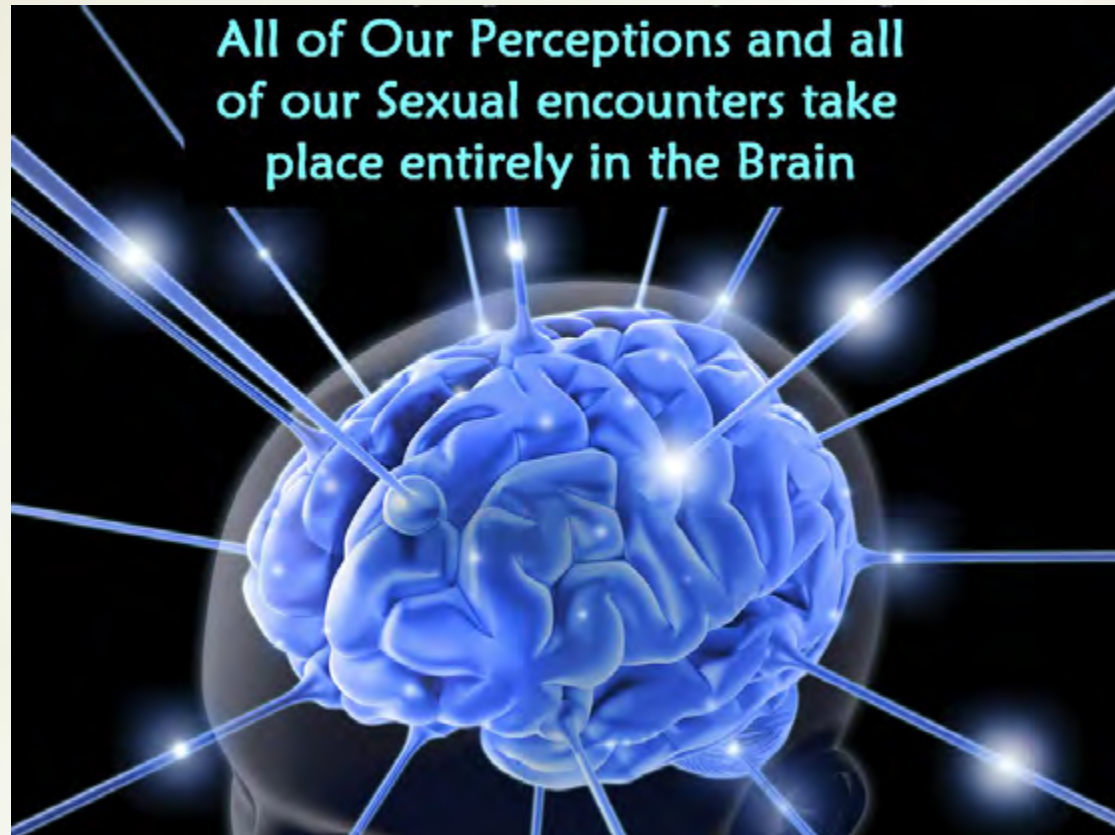

The most beautiful thing we can see is the mysterious.

It is the source of all true art and all science

There are powers in the human mind as I proved in the movie "Proof". The Ultra Rich and the powers of our society do not want you to know this. Scientists ignore this truth and are thus ignorant. Science is no longer the search for truth and understanding it is the search for funding. And they fear being laughed at for belief in the paranormal. But as we all know the world is not normal it is paranormal.

ESP and the paranormal are very real. The so-called Scientific Explanation is always an after Hind Sight often contrived explanation to dismiss the paranormal. There is in all of us the ability to influence (not control) the things around us and our life circumstance. Positive minded people succeed. Negative hearts fail. We say your attitude determines your altitude. Many books are made to tell us of the effects. All of our societies believe in the powers of the mind.

There also is a GOD consciousness that operates above. The collective GOD consciousness acts to help us protect us and to reward or punish us for our behaviors. This we call karma and it is a reality. If we are good we will draw good to us and if we are bad we will draw punishment to us. We are all in the classroom of life trying to learn about how to make ourselves higher conscious being. If you are alive there is more to learn.

We say there are no atheists in foxholes. It seems that when we are at the edge of the abyss and face death we are much more likely to feel God's presence. Now religion exists to help to teach us about God's grace and how to be a better person. Jesus was a teacher and he taught us the powers of the mind. He said it is not just the action of murder, it seeds are in the mind as hate. It is not the action of stealing the seeds are in the mind as wants and coveting. So Jesus took us to a higher level beyond actions to the mind where we need to learn control of our feelings and thoughts. He speaks of the powers of the mind.

But many religions become institutions they care more about their institution than the people in the religion. Some get off the beam and teach that actions are not important just belief. Jesus said by your works you will know them. He knew that how you act in the world is important and how you think sets the stage for your actions. Your mental state determines your actions.

Jesus was the finest and most known example of the paranormal. He did miracles that everyone today still knows. He cast out demons (for they do exist). He healed the sick with spiritual energy. He dealt with witches. The bible believes in witchcraft. The bible has much to say about witches and it is not nice.

Deuteronomy 18:10-11 "Don't let anyone use magic or witchcraft, or try to explain the meaning of signs. Don't let anyone try to control others with magic, and don't let them be mediums or try to talk with the spirits of dead people."

We need to heed these words and try to understand the warning. We have the powers of our minds but we have to be careful in how to use them. The Bible tells us to not use witchcraft so we need to define the difference from witchcraft and the powers of the mind.

PROOF of NON LOCAL UNIVERSE

The Big Bang Theory States that the entire Universe poured through a singularity in a flash. Ten to ten minus 43 of a sec approximately. There is a left over echo of a Cosmic Microwave Radiation that reverberates throughout the Universe.

Quantum theory tells us that particles that have shared a common quantum connection retain the ability to communicate.

Two twin photons separated to the ends of the universe share info. What is told to one is instantly aware by the other photon. The photons and neutrinos were made into electrons and protons. These congealed into the stars. Inside the star the incredible energy made all of the other elements. The stars collapsed and exploded making planets. This shift particles has produced some separation from the entangled quantic origin. But the Cosmic Microwave Radiation is still entangled.

The world and the universe have been bathed in the cosmic radiation for over 13 billion years. Thus there is a quantic link of all information of life.

The Ten Commandments says that there is a one God consciousness of the universe. We have proved it with Bell's theorem and Quantum science. So there truly is an omnipresent God that is connected to all that is. This is so vast as to think that an electron 200,000 light years away has a connection to us. So the first commandment is that there is a Universal God and that he should be first in our hearts and minds. We all need to understand that in a complex world of fractal forces there is truly a power greater than our own. We have to watch about this idol thing and not put anything above the one God consciousness.

Our bodies are made of electrons orbiting protons and neutrons. We were all taught in 5th grade that we and all things are made of this. The electrons never touch each other they are so charged and they repel when they approach each other. So no matter in the body touches anything. The fields of the outer electrons in any atom interact with each other. There are photons that do touch electrons and these photons share the Universal connection. What we are is a very complicated set of energy vibrational fields. These vibration fields have sonic keys that trigger extra links to the God consciousness. Some universal sounds of the name of god. So the second commandment says be careful with this name, don't use it to hurt people.

There is a background microwave radiation left over passing through the universe that was made at the time of the Big Bang. This was over 14.5 billion years ago, and there is still a left over residue of the Bang flowing through the universe. This is part of the photonic connectivity of subspace. So a God does exist or at least a God consciousness. And he asks that we give at least one day out of seven to relax and remember the connectivity of all, the third commandment.

We are electrical beings made of force fields in a vast universe where at one level there is connectivity to all. We are also dependent on other people made of electrical force fields. We are social beings that need networking and we need to share a world. So we need some rules for how to play nicely and share this world with our other electrical vibrational beings. DNA is a quantic thing that grows and peaks into existence then it slowly decays back into thermodynamic entropy and death. Our birth protects the future of DNA by perpetuating the transfer of DNA to our children.

The fourth commandment is to honor your parents. You should honor and respect them. You may not always obey them and you have the right to choose your own path but you should always honor and respect your parents. And this commandment has a reward attached. Because it says that if you honor your parents you will be given a long life.

The next four commandments are to not do actions that hurt other people. Don't kill, don't have sex with a person married to someone else, don't steal, and don't lie. Very simple ideas of social order that are a must for any society. These are laws against society, but in America and most of the world number six about sex was taken away from social law. But the others are socially enforced.

Next the commandments go to the level of mind not just action. Number nine is control your desire for sex with other people. And ten control your desires for their property. Here is where Jesus did most of his work telling us to control our minds is important than just actions.

QX World Conference 2010

"Energetic Medicine and the SCIO in depth"

Budapest, Hungary 07-10 October 2010

The International Medical University of Natural Education IMUNE who sponsors the International Journal of the Medical Science of Homeopathy and Natural Medicine wishes to invite all and any to attend our yearly world congress on medicine. If you would like to present material please send us a proposal. Please send us studies, letters, comments, articles, photos, testimonials, or stories for us to consider for publication.

If you wish to give a workshop, or have a booth please send us a proposal.

Please send us in acceptable form to:

Edit Barota - Conference Organizer
edit@qxsubspace.com



Every year in October, Prof William "Bill" Nelson invites you to the "QX World Conference" in the beautiful European city of Budapest, Hungary. Prof Nelson and his office staff, The Budapest Home Office, are the creator and manufacturer of the universal electrophysiological biofeedback system, the SCIO. Prof Nelson and his staff are living and working out of Budapest and this is a chance to meet them as well as numerous other Trainers and Speakers from around the world covering various topics connected to the device.

Subspace Treatise on the Collective Unconscious of the Universe

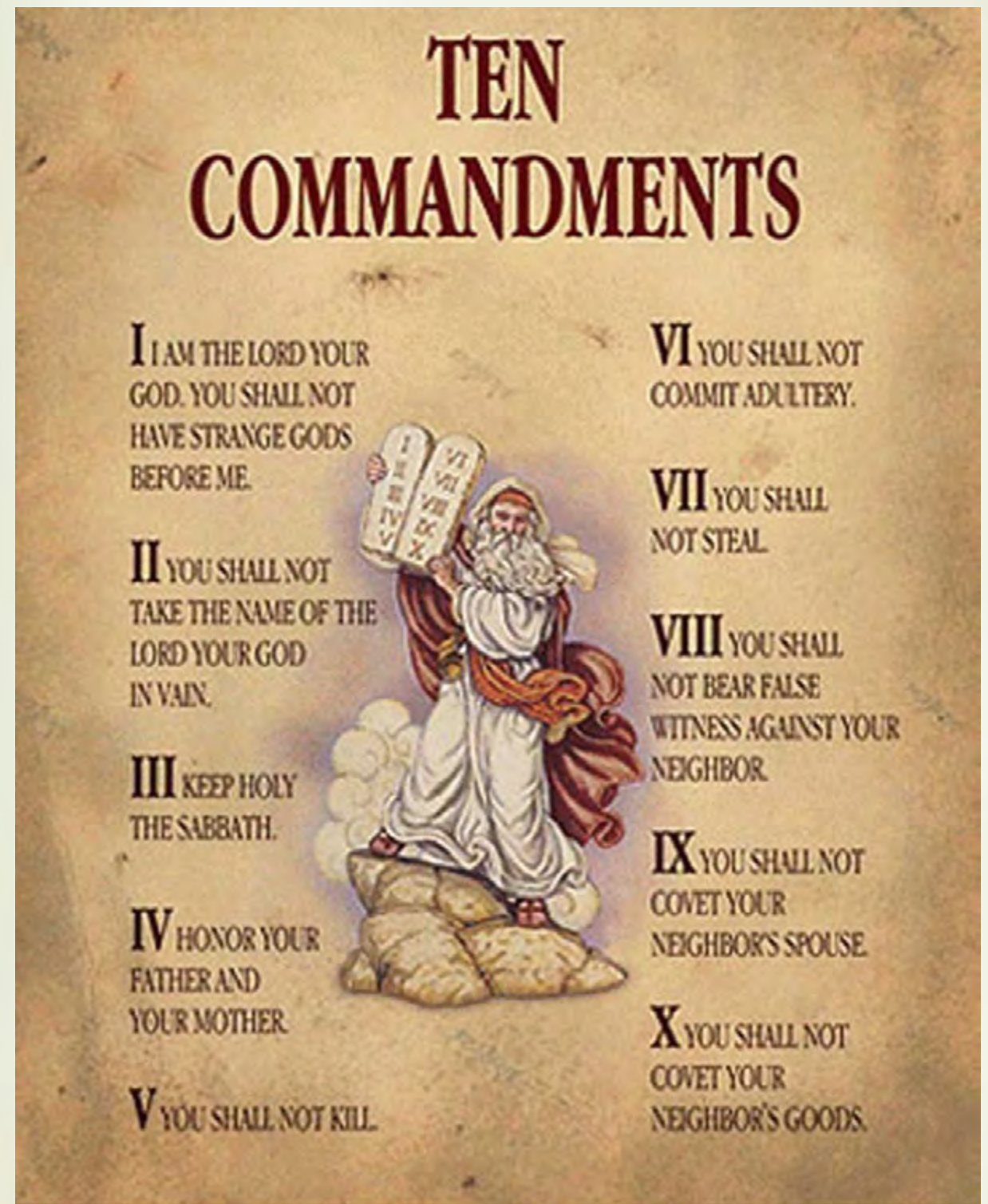

So we see that we are energetic fields in a vast interconnected field interacting with other energetic field beings. If we keep this perspective and our reverence for the whole we are working within the rules of existence. If we start doing our own thing with no respect for the whole it is witchcraft.



It seems obvious that it's not a good idea to put too much stock in witchcraft. But it turns out that 31 percent of Americans believe there are real sorcerers, conjurers, witches and warlocks out there. And that's just one of the several paranormal beliefs common among Americans, according to Gallup: 51 percent believe in ESP, 38 percent in ghosts, and 29% in astrology. Around the world belief is even higher. The truth is that witchcraft does indeed exist.

Galatians 5:19-20 says it is sinful to "being sexually unfaithful, not being pure, taking part in sexual sins, pharmakia (in the original Greek), worshipping false gods, doing malevolent witchcraft... wicked impure thoughts, eagerness for immoral lustful pleasure, idolatry, evil spiritism (that is, encouraging the activity of demons),..."

The reference to adultery was not present in the earliest manuscripts. It was apparently added later by an unknown Christian forger. The key word of interest here is the Greek word "pharmakia" from which the English words "pharmacy" "pharmaceuticals," and "pharmacology" are derived. Interpreted literally from the Greek it refers to the practice of preparing poisonous potions to harm or kill others. Just what some synthetic modern Pharmacies do.

Revelation 21:8: says that those "witches who do evil magic" will burn in hell.

What Is Witchcraft?

1 Samuel 15:23 (NAS) "For rebellion is as the sin of divination, and insubordination is as iniquity and idolatry..."

Exodus 8:7 (NIV) But the magicians [Jannes and Jambres] did the same things by their secret arts; they also made frogs come up on the land of Egypt. These magicians matched tricks with Moses. But when they both made their walking sticks into snakes, Moses's snake ate the snakes of the magicians, showing

God's superiority.

- *Witchcraft: Wanting to be a spiritual "mover and shaker" without submitting to God (or some form of the positive universal consciousness). Witchcraft is rebellion coupled with a desire to "control the game", to be more than just a spiritual player and put one's self before God. Rebellious youth often turn their back on God and mistake their energies (like the Drop) to be universal energies (like the ocean). The difference between Moses doing a miracle and Jannes with Jambres doing magic are if there is the proper reverence to the universal positive consciousness of God.*
- *Witchcraft is characterized by belief in "knowledge from below", and rejection of "knowledge from above". In its more advanced and powerful stages, delusion and belief in what is clearly not of God is key. Satan's tacit "deal" is: if you sacrifice truth on his altar, he will give you power for what you want now. But lies are flimsy things to put your trust in... because Satan will lie and take away your happiness.*

There is power in the universe and a universal consciousness. God's ways are unknown to us but his power can be felt. If we are working with God and letting God power work thru us we can use the power within us to do God's work. When the drop thinks it is the ocean, when the person tries to do things around God's power, or when the person derives power from evil self serving ideas then it is witchcraft.

Exodus 8:18 (NIV) But when the magicians tried to produce gnats by their secret arts, they could not. And the gnats were on men and animals.

Acts 8:9-11 (NIV) Now for some time a man named Simon had practiced sorcery in the city and amazed all the people of Samaria. He boasted that he was someone great, and all the people, both high and low, gave him their attention and exclaimed, "This man is the divine power known as the Great Power." They followed him because he had amazed them for a long time with his magic.

Exodus 22:18 "Death is the punishment for witchcraft"

I made my angel of god book to try to help people get to the 1000 years of peace and harmony, the millennia. This book heralded my work to save the planet by confronting our false beliefs. I sought then to try to show the more sexual side of my persona with an outrageous book. I thought the sexual warrior witch to be a provocative title.

At first it was tongue in cheek and I wanted to not hide my persona but to put it forth honestly and to show sincerity, with honor and integrity. I recognized the compromise of dignity but truth was truth and for our society to allow chick to have a dick the sensual side of the story needed to be told.

But the use of the witch was wrong. For being a devout religious person and one who takes the bible very seriously I needed to rethink. So I decided to not use the word witch and to have another title. Spirit, Diva, Enchantress came to mind but finally Provocateur seemed the best. The Sexual Provocateur became the title.

In all that I do I take direction from God. I studied the ancient coded sounds and symbols of Solomon and the Torah as well as other cultural similar keys to protect myself and open the doors to the universal positive consciousness of God. Thus there is a mutual working of prayer and reverence in all that I do and if you will do the same you can use the help of this book in positive ways to enhance your life. If

you tune yourself to a power greater than yourself a power of light and compassion, you have already enhanced your life.

The Lord's Prayer

**Our Father in heaven
Hallowed be Your name
Your kingdom come
Your will be done
On earth as it is in heaven**

**Give us today our daily bread
Forgive us our debts
As we forgive our debtors**

**And lead us not into temptation
But deliver us from evil**

**For Yours is the kingdom
The power
And the glory forever**



So references to witch and witchcraft are just tongue in cheek and to be understood as sexual imagery meant to be provocative and stimulating. As you will see the only difference between prayer to get what you want and sorcery is whether you involve God or not. If you are reverent to God's will, and obedient to his laws and you request respectfully his help then you request is a prayer, I involve God in all of my actions. I try to live such that everything I do is a prayer to his splendor and glory. Even my sexuality is a joyful, reverent playful song to the power and glory of God. Small minds criticize this but small minds criticize everything.

Sexuality is not bad it is part of the process of joyful living. If you are giving pleasure and hurting no one, then the acts of consenting adults can be a spiritual exercise. The sex act itself is an orgasm of the lower chakra. Thru kundalini yoga I have learned to open and thus to orgasm in all of my chakra. I will discuss this somewhat in this book and in more detail in others. So welcome to this honest open disclosure of a deep part of myself that will help you to perhaps find yourself as I have found me. Prudish people, sexually immature, and mentally unstable people will not like this book and they should not read further. But for normal open minds this book will be a turn on for body and mind. Use wisely and go with God.

The Wisdom of Solomon gives us an outline of how to call upon the God consciousness of the universe for protection and inspiration. It comes to us from multiple sources and multi-cultural legends. The sounds and style have a universal archetypal structure that is repeated in all cultures. Solomon taught us how to invoke the God consciousness and to discern it from the dark forces that can trick you. This prayer protects and makes sure that God is answering you not anything pretending to be God. George Bush said that God told him to invade Iraq. Here a little clue if he's telling you to kill people it is not God. What was talking to George was a false demon pretending to be God. Solomon wrote a way to assure it is God that you are in discussion with.

The following picture is the gateway. By facing north and seeing the Archangel Ariel to the North, Archangel Uriel to the East, Archangel Michael to the South, and Archangel Gabriel to the West. We call on them to protect us, our families, our friends, our businesses. These angels offer protection and we need protection from demons before we call on the name of God. The letters of God's name from the religion of Abraham are tetra, gram, mut, ton all recited to the directions of the compass like we did with the angels.

Now we call on God and recognize that there is one God consciousness of the universe. It has many names in many languages, but still one universal omnipresent force. We call on this force using the names of god.

Now with respect we first must recognize we are but a speck of a speck of a speck on infinitum. We do not know the ways of God and thy will be done on earth as it is in heaven. Give us some bread and meager things, and protect us and help us with temptation. Let us forgive and be forgiven. We will not do unto others what we do not want done to ourselves. We wish no evil, injury or even the tiniest harm to anyone. We ask that evil be sent back to its origin three times three to teach the evil ones the lessons of compassion. We ask before you oh God a favor if you will.

The spells and incantations referred to in this book are mere favors you request from the universal mind of the consciousness of all. These are request to help you and others find health, happiness, and contentment. If you use these spells with this introduction and in this form of mind it is not witchcraft but prayer. You have power and with the help of God you can increase that power. You can affect things but not control them. God does this not you. But your powers can increase.

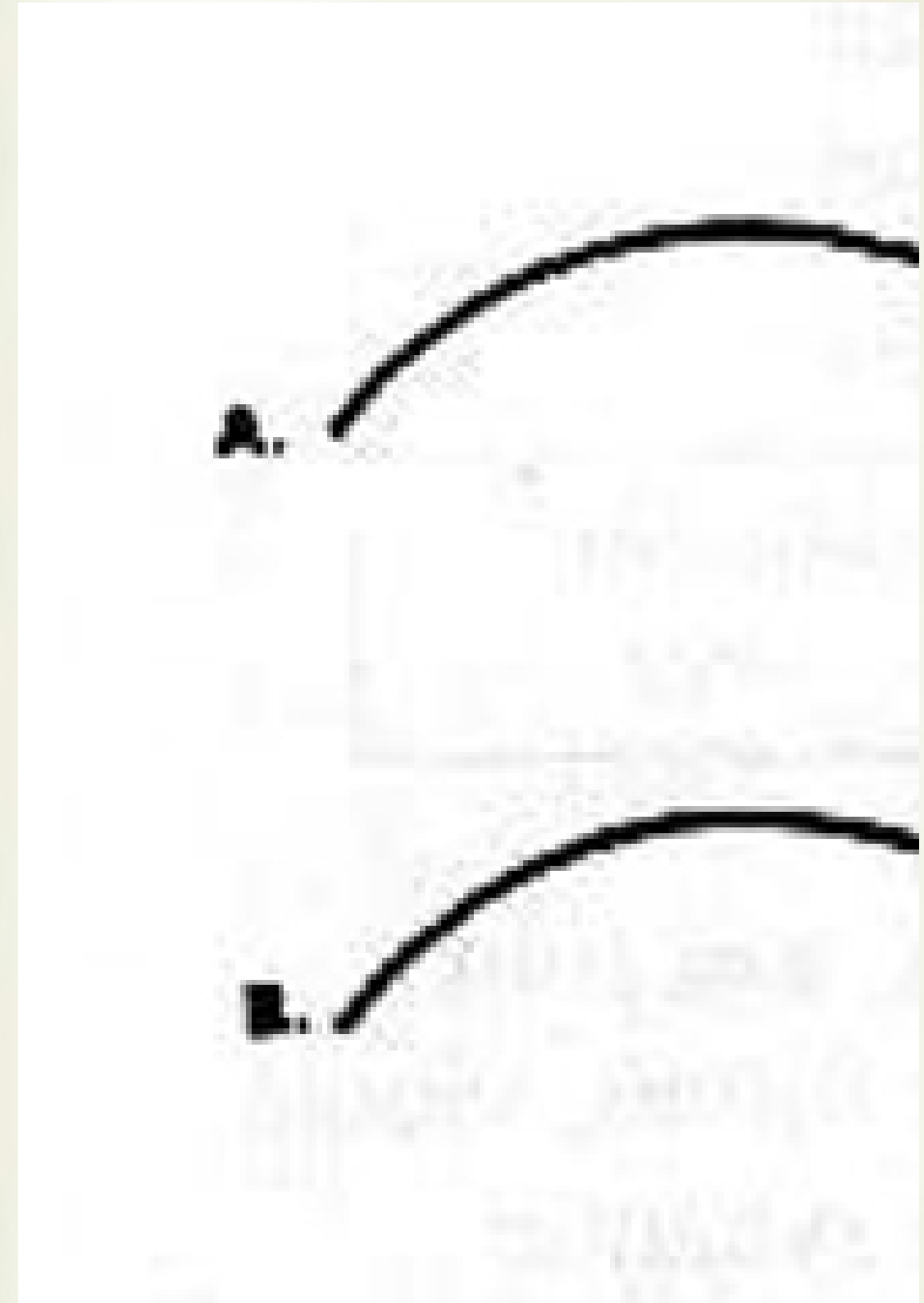

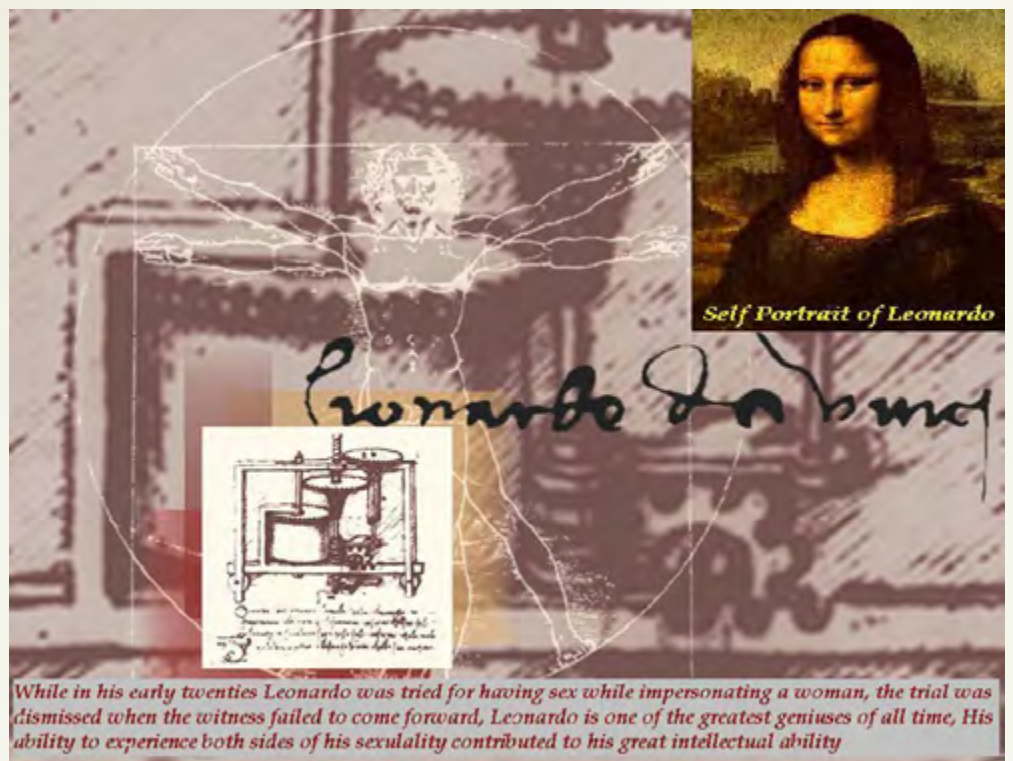

We don't go to war over the pronunciation of apple.

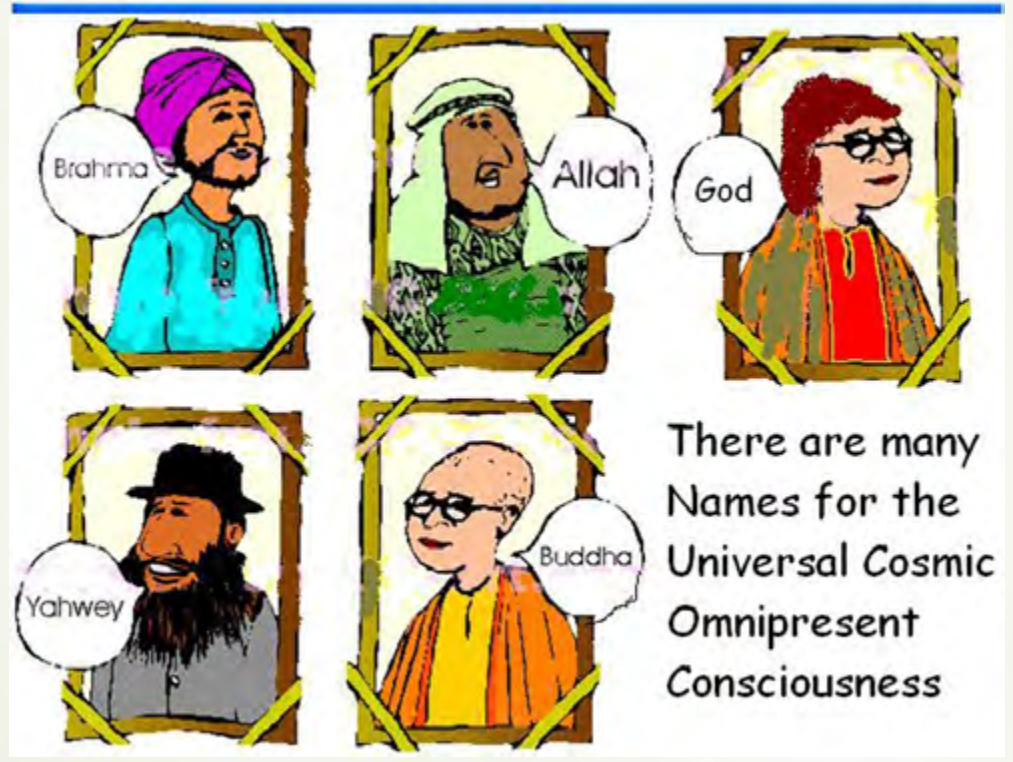

We should not go to war over the pronunciation of the word for the Universal Consciousness.

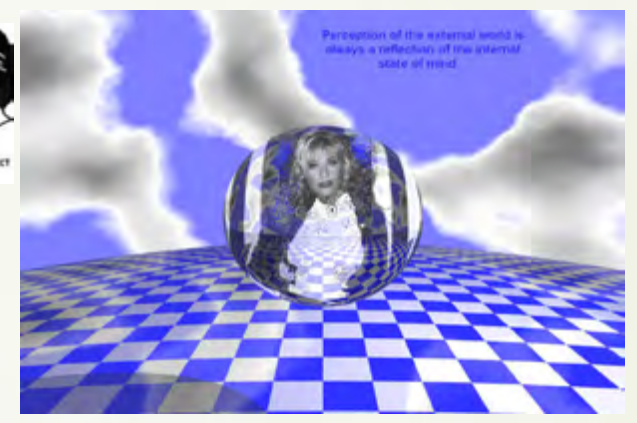
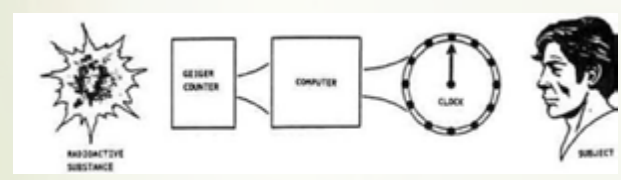

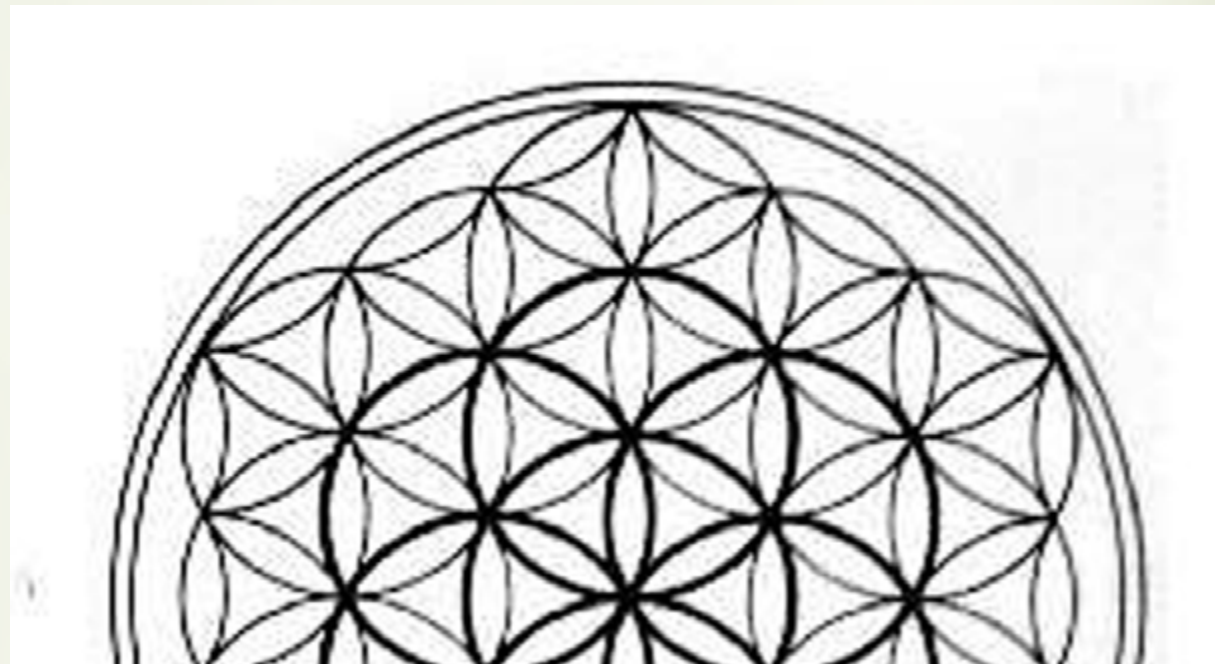
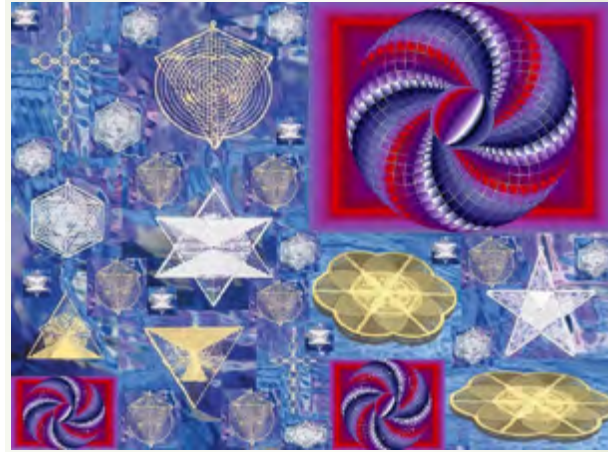
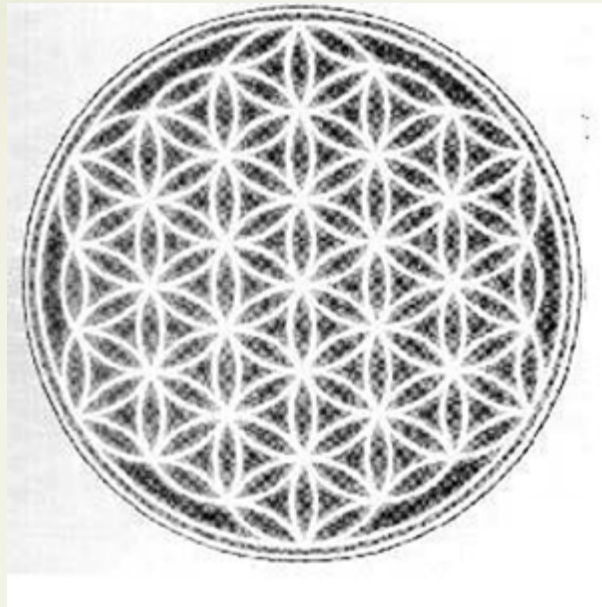

With peace harmony and compassion for all I wish you some joy and entertainment in reading this book. There is a God consciousness of the universe and if we respect it and work with it, the universal God consciousness will respect us and work with us.

So we see that we are energetic fields in a vast interconnected subspace field interacting with other energetic field beings. If we keep this perspective and our reverence for the whole we are working within the rules of existence. If we start doing our own thing with no respect for God, his name, our parents, for others, or for even ourselves, it is wrong.

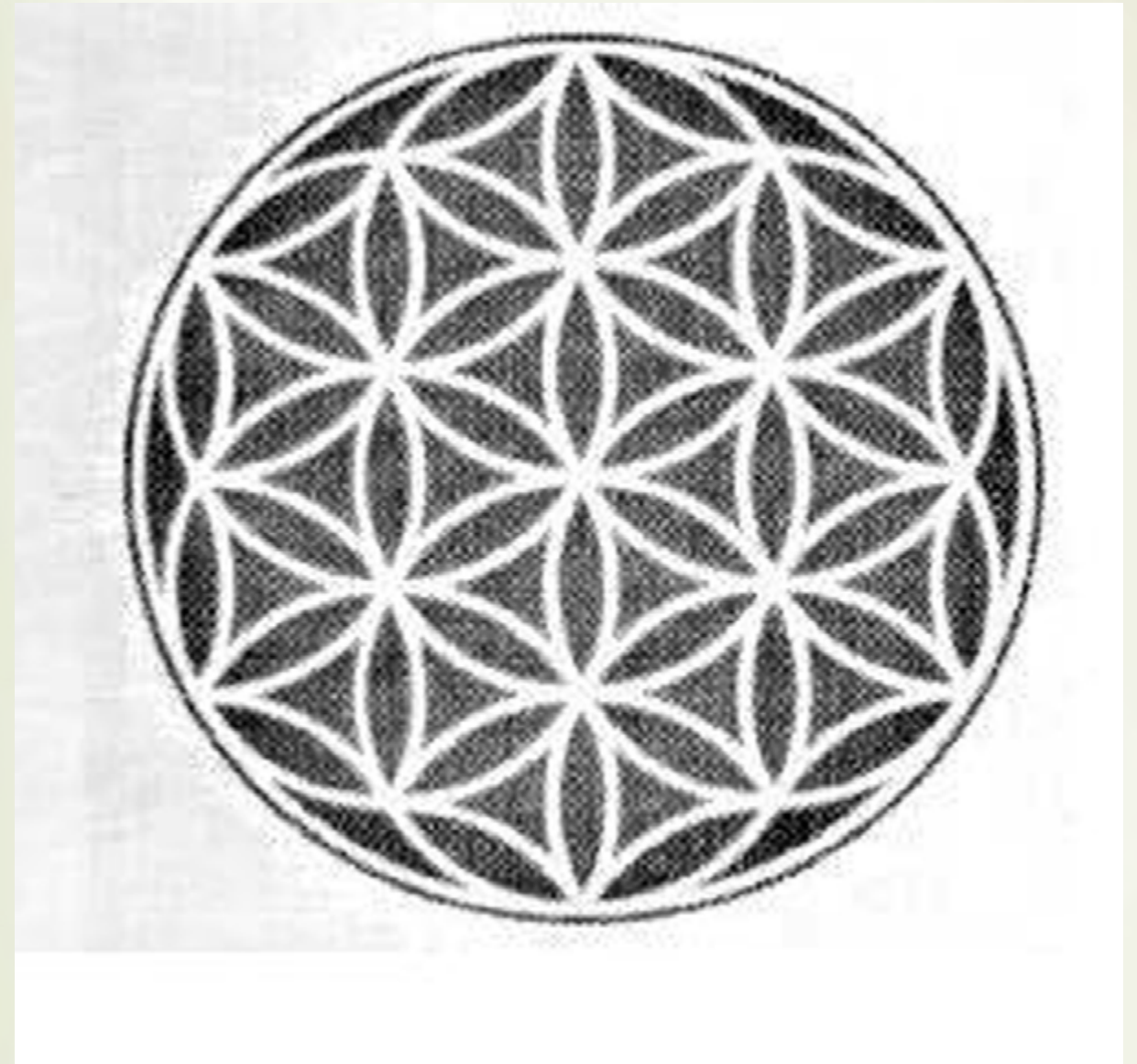

Matter is energy. Our bodies are made up of interacting subtle energetic fields that we cannot perceive. Some of these fields have a spiritual source that act on a person's spirit and soul. The soul is developed thru a process of guided self observations and discipline of the mind thru non-judgmental awareness. True soul development rarely happens due to man's unique ability to be distracted from spiritual matters by words and everyday trivia. The spirit is sidetracked by emotional desires of greed, anger, delusions of false beliefs, arrogance and the need for conformity. So true spiritual development rarely happens. People seek to find a higher degree of humanity and achieve self actualization but few can transcend conformity and find a higher level of enlightenment.

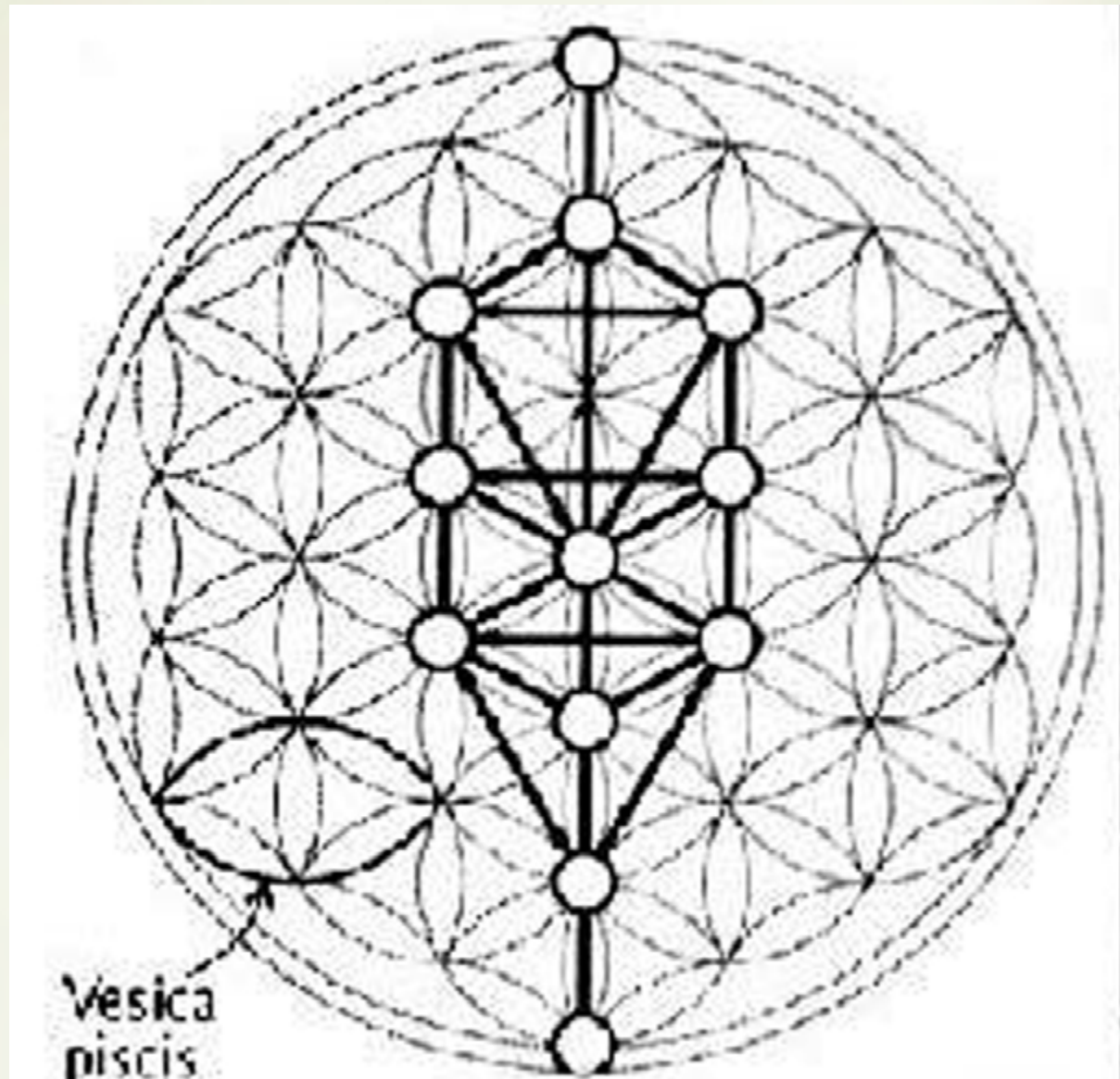

Past the ten commandments of European and American culture the American Indian said what of mother Earth where is Mother Earth in your cosmology. There needs to be added a reverence for our planet to help stop our ravaged destruction of the planet for greed and money. So to the Ten Commandments we need to added treasure the land and remember what so sow you reap. If you use synthetic chemicals to sow, you will reap them.

There are over 100 Billion Neurons in the Brain

The Brain receives Photonic, Electrical, Chemical information from all of the cells of the body to Regulate all of the Body Processes

This means there is 10 to the 18th bits of information going to the brain every second,

But the Reticular Activating System (RAS Word Brain) can only handle 1 million bits of Data a second or it is overloaded

So the word area is getting one percent of one percent of one percent of one percent of one percent of one percent of one percent of one percent of one percent of the information of life.

The Rest is going to the Body Electric.

With the DNA of 100 Trillion cells sending information to all of the Brain, It is an Overwhelming task of the Body Electric.

There are approximately 10,000 cellular Operations Happening every second

DNA use photons and electro-magnetic effects to transfer information

<i>Organization</i>	<i>Guided Indeterminacy</i>	<i>Unguided Indeterminacy</i>
<i>Governed by</i>	<i>Life Principle Organized Indeterminacy</i>	<i>Uncertainty Principle</i>
<i>When Observed</i>	<i>Responds to Observation</i>	<i>Responds to Observation (Mind of Observer)</i>

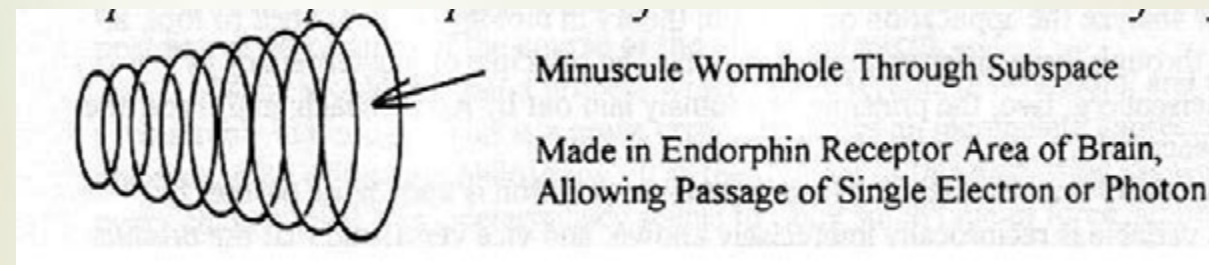

Prof. Desi's

DOCTORATE IN WELLNESS COURSE

IS BASED ON A HOLISTIC MODEL
MIND

As a man thinks, so is he. Desi was one of the first credentialed graduates of NLF and she was a licensed psychological counselor in Ohio. She teaches how to help any person with any disease to improve in this wellness course.

These is a simple word for Wellness... CARE
Care for yourself and your family



BODY

You are what you eat. We need to intake more healthy vegetables and fruits (25% raw), use lots of juices, drink lots of water. Eat good cold processed vegetable oils.

No cooked oils or long cooking with oils. Eat good non-processed fructose fruit sugars. No bad processed dextrose sugars.

Exercise, love, kindness, caring and respect are nutrients. Get them and give them daily.

Fractal & Chaos theory have taught us of the complexity of humans. We must respect the whole individual not the reduction of their parts. A small flaw on any part might amplify a disease elsewhere.

SPIRIT

The mind of God fills the universe with subspace. We need to be able recognize the powers greater than us and with reference and respect for all things actively cooperate with the Great Spirit. We need to listen to the Positive Force and resist the Negative Forces. It is an illusion that we are separate

We need to expand our circle of compassion to include all things in the Universe.

ENVIRONMENTAL

What we sow, we reap. We must work with our environment and all work to make a less Carbon footprint and make a greater Oxygen footprint. By eating more fruits and vegetables and less meat we increase the Oxygen while decreasing the Carbon.

Everyone must cultivate more plants, shift from fossil fuels to Bio-fuels and Bio-mass fuels.

We must stop the toxic poisoning of the world and work to help us return to the Garden.

The verbal word area of the brain is about the size of a golf ball on just one side of the brain. The Reticular Formation filters the 10 to the 15th plus bits of data coming from our cells to the brain. And the Reticular Formation filters the information so that only one million or so bits of data go to the word area of the brain.

The autonomic functions of digestion, immunity, growth, detox and health itself are thus not under verbal control or should they be. Science has made the mistake of thinking that the verbal mind is all that there is. If I am not verbally aware of it how could it be important. This false belief has polluted medicine. The verbal mind is reductionism, simple, and prone to false beliefs. Classic biofeedback enlarged this mistake. The body electric is in the whole and operates non-verbally and holistic a type of Gestalt integrity.

By making a cybernetic loop to the body electric the Angel has developed a superior form of biofeedback that can balance and repair the body electric. This is the advent of a new medicine.

SOCIAL

We are social beings that need networking feedback to help us grow and mature. We need to foster compassion, cooperation, connection, and care. We all share air. We need to share Care.

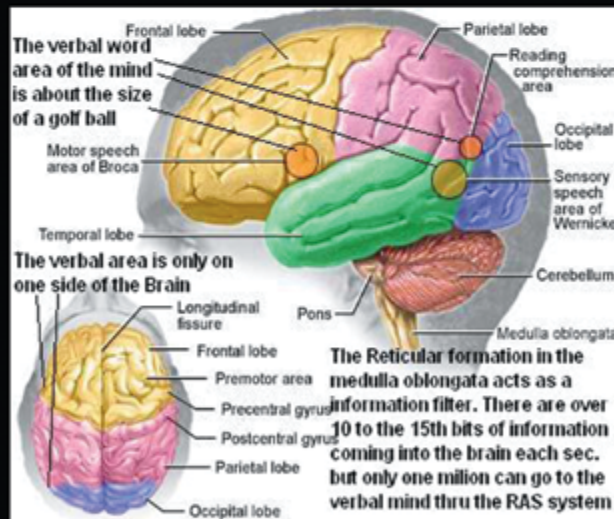

The contrast of cultures we call east and west can display the contrast of the verbal versus non-verbal brain. The words are arrogant, destructive, greedy, judging, plotting, scheming, trying to protect the ego more than respect for the planet. The eastern more Buddhist way is based on mindful non judgemental awareness of the whole and respect for the process. As we see how the Western arrogance has almost destroyed this planet we need to be more balanced and recognize that the verbal area is a good tool but should not be the master.



fill the room with your intelligence...