

ISBN 978-615-5169-11-3 Homotoxicology



HOMOTOXICOLOGY



Table of Contents

Allopathy	5
Surgery	17
Cancer and Persecution	21
<i>Conditions listing medical symptoms: Tetany A to Z:</i>	25
<i>Homotoxicology differs from Classic Homeopathy</i>	36
<i>The Greater Defence System</i>	42
<i>The therapy in Homotoxicology is based on THREE PILLARS:</i>	43
<i>References</i>	45
<i>About Quantum Biofeedback</i>	47
<i>Hormesis</i>	50
<i>References</i>	53
SCIO-Bio-Electronic Supported Elimination of Toxic Substances from the Human Body (SCIO Detox)	60
<i>Abstract</i>	60
<i>Introduction</i>	60
<i>What are toxins and what is detoxication?</i>	61
<i>Let us give names of some of these items mentioned.</i>	61
<i>What symptoms does someone have if his detoxication is insufficient?</i>	62
<i>What does the status of toxic balance mean?</i>	62
<i>Methods and Materials:</i>	63
<i>Discussion:</i>	65
<i>Bibliography</i>	65
<i>Appendix 1</i>	66
<i>Appendix 2</i>	67
<i>Appendix 3</i>	68
<i>Appendix 4</i>	69
<i>Appendix 5</i>	80
<i>References</i>	82
QXCI and The Long-term Pathological Findings of the Camelford Toxicity Group	84
Basic Science	90
<i>The Human Body Electric</i>	96
Proton and Electron Balance	101
Meats in your Diet	111
<i>Pig & Pork - Toxic Facts</i>	124
<i>Toxins and poisons in your environment. These are things everyone should know about</i>	127
Homotoxicology and Pathology	152
<i>HOMOTOXICOLOGY</i>	152
<i>INFLAMATION</i>	153
1. <i>The cell and cell injury</i>	155
2. <i>Cellular adaption and ageing</i>	174

3. <i>Acute inflammation</i>	181
4. <i>Healing</i>	194
5. <i>Chronic inflammation</i>	202
6. <i>Immunopathology</i>	211
7. <i>Resistance to infection</i>	225
8. <i>Immune deficiency</i>	230
9. <i>Granulomatous diseases</i>	236
10. <i>The effects of infection and injury on the body</i>	250
11. <i>Fluids and ions</i>	265
12. <i>Oedema and congestion</i>	270
13. <i>Hypertension</i>	277
14. <i>Atherosclerosis and aneurysms</i>	283
15. <i>Thrombosis, embolism, and infarction</i>	293
16. <i>Congenital and inherited disorders</i>	302
17. <i>Neoplasia</i>	313
18. <i>Iatrogenic disease</i>	346
19. <i>Alimentary system</i>	348
20. <i>Liver, gall-bladder and pancreas</i>	370
21. <i>Cardiovascular system</i>	389
22. <i>Respiratory system</i>	402
23. <i>Urinary system</i>	420
24. <i>Reproductive system</i>	433
25. <i>Breast</i>	442
26. <i>Endocrine system</i>	445
27. <i>Haemopoietic and lymphoid tissues</i>	459
28. <i>Connective tissue diseases</i>	469
29. <i>Musculo-skeletal system</i>	475
30. <i>Nervous system</i>	483
<i>Neuroblastoma</i>	496
GENERAL DETOXIFICATION AND PREVENTION	499
DETOXIFICATION	501
XENOBIOTICS	501

The cost of this book is 146 Euro. The copyright is owned by QX Ltd., all rights reserved.

Please pay to the pay pal under [desifm.net](https://www.desifm.net) under donations. All of the books have low res for size and hi res versions for clarity.

If you do not have the money pay what you can, and if you cannot pay anything please pay the cosmos back with good deeds to others. Pass on the good karma by being good to others and helping them the way I am helping you. Pass it on.

IMUNE

International
Medical University
of Natural Education

Desiré is the Professor Emeritus of IMUNE. IMUNE is an accredited and legally registered medical university in Europe.

Since 1995 IMUNE has been offering medical education in a variety of subjects to defend and perpetuate Natural Medicine. There are many small minded people being driven by the SINthetic chemical companies to destroy Natural Medicine as a viable choice in Medicine. IMUNE has offices in Switzerland, Mexico, Dubai, Budapest, England, and the British Virgin Islands. The small petty minded picayune minions of the chemical companies constantly attack with their anal retentive biased short sided views.

We must fight for freedom of choice and especially freedom of choice on medicine.



Education...
...free from Borders www.imune.net

Allopathy

The principle of allopathy is to only reduce and or address symptoms. The question "What's Wrong with You" is the key. The answer details the focused complaint and not a true access of health or welfare. When we combine this with pills made and tested for the symptom we get a medical system where the average visit is less than one minute of real concern. Consider the side effects and you get an ever expansive cascade of errors that cost our society vast amounts in terms of money and human suffering. Allopathy has failed as a medicine philosophy and it just takes time for all to realize it.

You get some heavy metal toxins in the back of your throat and the bacteria and fungus are helping you to detox with a sore throat.

But what if you are so unlucky, so misfortunate, so ill-fated, so wretchedly miserable star crossed luckless, that you go to an Allopath for help?

You have a pinched nerve and you have pain

But what if you are so unlucky, so misfortunate, so ill-fated, so wretchedly miserable star crossed luckless, that you go to an Allopath for help?

You have excess stress and your body has extra menses to detox

But what if you are so unlucky, so misfortunate, so ill-fated, so wretchedly miserable star crossed luckless, that you go to an Allopath for help?

You have depression from losing your job

But what if you are so unlucky, so misfortunate, so ill-fated, so wretchedly miserable star crossed luckless, that you go to an Allopath for help?

Your diet is bad and you have some heart pains

But what if you are so unlucky, so misfortunate, so ill-fated, so wretchedly miserable star crossed luckless, that you go to an Allopath for help?

In all of these cases and many more your allopath will not deal with the causes of your disease but instead give you a pill, a fast cover-up, a quick fix that makes profit for the chemical companies. All the allopath considers is your symptom. He spends 30 sec considering your case and deciding what pharmaceutical to give you.

All of SINthetic pharmacology is designed to either block natural functions or over stimulate them. In either event they do not work with nature but against it. If you are potassium deficient as in a heart patient, they prescribe a calcium blocker rather than a potassium diet. SINthetic potassium pills were found to be hurtful and the doctor does not want to become cooks, so they made calcium blockers. If you are depressed you get a MAO inhibitor, for a fever and antipyretic, for pain a pain receptor blocker. For depression you get a serotonin uptake blocker. In each and every event it is unnatural and does not cure anything. Most of the time you are just building dependence and this is good for the drug companies who depend on continued use not real cures. In my book "Receptor" I go thru all of the pharmaceutical drug types and expose the unnatural and hurtful aspects of their use.



Our teenagers don't have their own goals anymore.

Obay™ works like a charm.



From the makers of WhyBecauseISaidSo.™

The Drug Companies want to turn our Society to a pill for everything



“Take two, twice a day to help control rage. By the way, I put them in a child-proof bottle and overcharged you.”

We offer the Nelson method of medicine for you to consider as an alternative:



In step four we do allopathy. We address reducing uncomfortable symptoms. This is part of medicine, but should not be all of medicine. And we should always use natural components, like food, exercise, homeopathy, herbs, etc to treat symptoms before using any such harsh synthetic patent medicine.

Many years ago in Denver a man approached me who was a salesman for a survey company. They sent out survey questionnaires to all kinds of professions to find out more about marketing. He gave me 4 questions for free and they were mailed out to over 100,000 medical doctors. The first question was "would you use a Natural pharmaceutical over a synthetic one if you could?" 82 % said yes. One of the questions was which of the following would you use in your practice?

1. Acupuncture
2. Biofeedback
3. Nutrition
4. Homeopathy, or
5. Allopathy.

55% said they would use Biofeedback, it was technical and scientific.

45% said they would use Nutrition.

35% said they would use Acupuncture.

12% said they would use Homeopathy, and

5% said they would use Allopathy, even though these were allopathic doctors who use allopathy every minute. They do not know or understand the art of medicine they use. They do not know what it is or how unsound the philosophy is behind it. They are too busy learning what the drug companies want them to learn. They are afraid to challenge the drug companies. They know what happens to those that do. They live in fear and when the drug companies say to do something they do.





The Allopathic Medical Team of doctors Dewey, Drugem, and Howe work at the Take Your Meds Medical Clinic at the corner of Induce Vomiting Road and If Symptoms Persist Take More Drive. They have some advice for you.

We wake you up to give you a sleeping pill. We give your Hyperactive children speed.

Antibiotics are contraindicated in viral condition but we give them to you anyway. The antibiotics are immunosuppressants This way we can start children out right on a lifetime of using medications and treating consequent side effects.

Whatever your symptom we have a pill maybe two, they will always give you another symptom but don't worry we have another pill. Don't worry no matter how many symptoms you develop we won't run out of pills. We have pills for everything.

Prozac limits depression but blocks the ability to connect to reality so it can make some one a mass murder, but don't worry we have enough prozac for all of the victims as well.

Cholesterol lowering drugs decrease sex interest but our new viagra treats that symptom as well, and we think with the little head as good as anyone.

And our steroids can block your natural healing response better than anything. Healing is not our job, We manage symptoms. Bring us your symptom we got a pill, we're busy.



Using a pain killer never deals with the cause of the disease. The Nelson Method deals first with the cause.

COUNTERTHINK



GunShots Ring out on the Street Again



"I'LL HAVE TO GET DR. KENDRICK TO REDUCE HIS DOSAGE OF PROZAC."

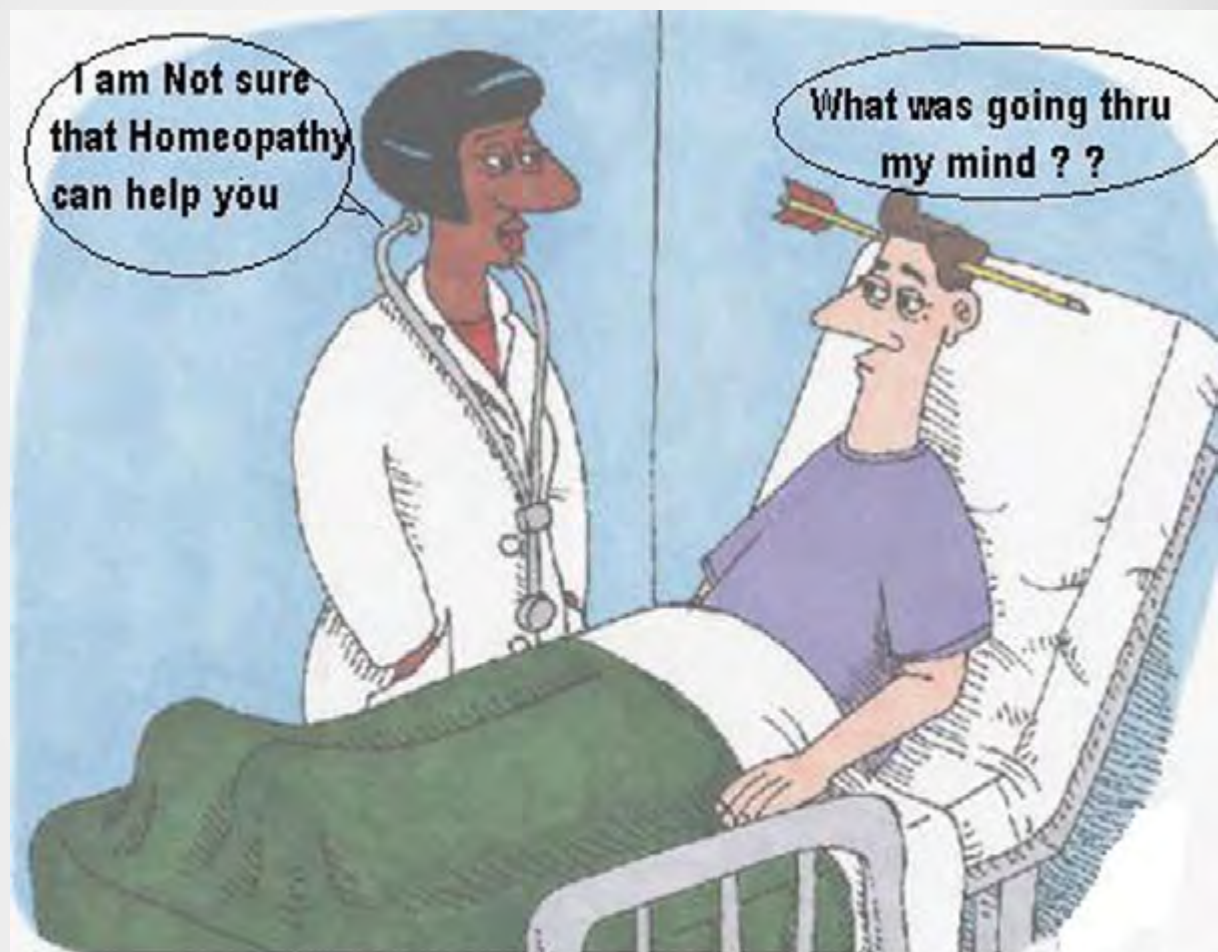

We need the field of SINthetic Drugs for many things like emergency medicine, homeopathy can't help in these cases but most presenting concerns in a doctors office will respond to life style changes, nutrition, herbs, homeopathy



Surgery

Abraham Maslow once said "if the only tool you have is a hammer, you will treat everything as if it is a nail". Surgeons have a surgical answer for everything, and nothing is more risky and costly than surgery. We need surgeons and surgery. But profit motives can put a burden on the health care system if we let rampant greed get out of control.



Fasting is the best surgery. We must recognize that the cancer is a mutated form of your DNA. Some radiation, toxin, or virus has altered your DNA and the mutated form of you is the cancer. Your white blood cells have your DNA. They are little yous who do battle to save the big you. They sense that the cancer is not really you and attack. Sometimes the cancer makes a shield of the fatty acid aracadonic acid from a deficiency or excess of fatty acids and this prevents the white blood cells from seeing the not you cancer. Sometimes the mutation is not great enough for the WBC army to know it is not you. Sometimes we need surgery.

Sometimes your immune system is just not strong enough to defeat the cancer intruder. From extra dextrose sugar, stress, drugs or just plain age, your white blood cells might be weak. If you're following all of the advice in this book you are now building a stronger white blood cell army.

"There is a time for all things under heaven" as the Bible tells us. There is a time for surgery when the cancer is too large for the immune system to handle, or because there is a toxin in the cancer that the body cannot detox itself. Remember the piece of glass in my father's cancer. Sometimes a piece of glass asbestos cannot be detoxed without cancer. But the reason you have cancer is not because you are surgery or chemotherapy deficient. The reason is toxins (like smoke), virus, radiation, fatty acid deficiency, or weak immune system from sugar use or stress. Surgery can maybe help but after you recover go to a healthy life style. Always get a second opinion.



Get a Second Opinion From 'Another' Doctor.

Fasting is a natural surgery, but it is not indicated when you are about to get medical 'cut you open' surgery. People who have too little protein in their blood have a much greater chance of dying before surgery. Before surgery to get the albumin protein into their blood, eat 6 to 10 hard boiled eggs a day for three days prior to the surgery. This will get your albumin protein up to snuff. Get lots of good vitamins and good nutrition before you go to surgery. And remember Hospital foods can kill so ask permission to get some good nutrition from real foods not processed, white sugar coated, trans-fatty acid rich hospital crap.



The Allopathic Surgical team of Dr. Cutem and Dr. Stiche, work at the Operation Amputation for all Medical Clinic at the corner of Signthewaiver and Pay they have some advice for you.

When your drugs fail we have an answer to your problem guaranteed to shut your patient up.

If your wife is hysterical we can easily do a hysterectomy

If your child has persistent allergies we can remove the adenoids. Aids can result but

If you can not control your mood, have trouble playing with others, and can pay a large bill then a prefrontal lobotomy is for you.

If you don't like your body we can alter it for you, you still won't like it after as that the problem is the mind not the body, but as long as you have money come to us.

When your joints give out from lack of exercise we can put in a new joint, cheap.

If there is a build up of water in your child's ear we can put in a drain tube and ruin the ear no matter what the cause is. We hope when child grows the ear improves

In fact we don't care about the cause of disease we can cut, burn, +stab a new you for any known condition your insurance company is willing to pay for.

Those who Can't Teach, Can't Change that is.

He is truly out of date

He is lost and is without a clue BUT he controls my education!!!

Medicine is based on one hundred year old Science

New ideas are scoffed and Harumphed at

"The medical students listened politely as the 'professor emeritus' explained why the liver ultrasound reminded him of his combat days in South Korea."

SO TO END DEGENERATIVE DISEASE *we must*

1. Make Big Tobacco pay for the damages they incur
2. Must stop sales of cigarettes
3. Make Big Sugar pay for the damages they incur
4. Make Big Pharma pay for the damages they incur
5. End Allopathic philosophy and develop a new stressor reducing based medicine
6. Avoid Bad white processed sugars. Eat Good Sugars from fresh fruit, Avoid bad oils cooked or saturated. Eat good oils from fresh and raw vegetable and uncooked low temperature made oils.
7. Equal Economic Education- and a new medical education based on natural science.
8. Safe forms of early intervention medicine such as energetic biofeedback
9. Recognize the powers of the mind such as in the EPMX/SCIO system.
10. Recognize the need for an energetic medicine to safely evaluate the body electric and balance the aberrations of the body electric. We need to use a more modern medicine utilizing the body electric without emphasis on synthetic chemistry.
11. Recognize that the SYNthetic experiment has failed and we should be using the synthetics only in extreme cases when the natural remedies fail. Quantum Electrodynamics has further proven the problem of synthetic chemistry.
12. Allopathy does not work, we must adapt a safer and more extensive theory of medicine.

With these social changes degenerative disease could be so greatly reduced to allow for an inexpensive medicine.



Medical schools have become arrogant, outdated, biased, ignorant of new science, and vindictive snobs. They fear and dismiss all new ideas, especially if it exposes their false beliefs.

Cancer and Persecution

Cancer is still listed as an incurable disease. The accuracy of cancer diagnosis is not perfect. Many many People taking chemotherapy die, vast numbers of people taking radiation die. These are medical facts. Medical facts I have the freedom to express. Patients need to seek second opinions and do whatever therapies they can to try to deal with an incurable disease. Thousands of testimonials and a history of studies on the EPMX technology point to the proposition that the technology can help patients. We do teach at IMUNE that stress reduction helps all diseases. Cancer is a disease of the immune system where the reticulo-endothelial system immune system fails to attack the cancer effectively. The reticulo-endothelial system immune system is enervated by the para-sympathetic nervous system and thus is improved by stress reduction. Good nutrition, exercise, herbs etc can all have some small to moderate help, but help nonetheless. With such a

cascade of destruction possible any help is needed. Competent medical personnel today all realize these simple facts. We teach how to help increase health at our International Medical University. We mention this discussion with cancer to get your attention.

The more intelligent or educated a cancer patient is the more likely he is to go to a natural doctor. The sense of logic in natural medicine and the sense of Synthetic chemo-phobia make this fact very understandable. The harshness of the chemotherapy leads to more deaths from chemotherapy than cures, all in a vain attempt to get statistical satisfaction.

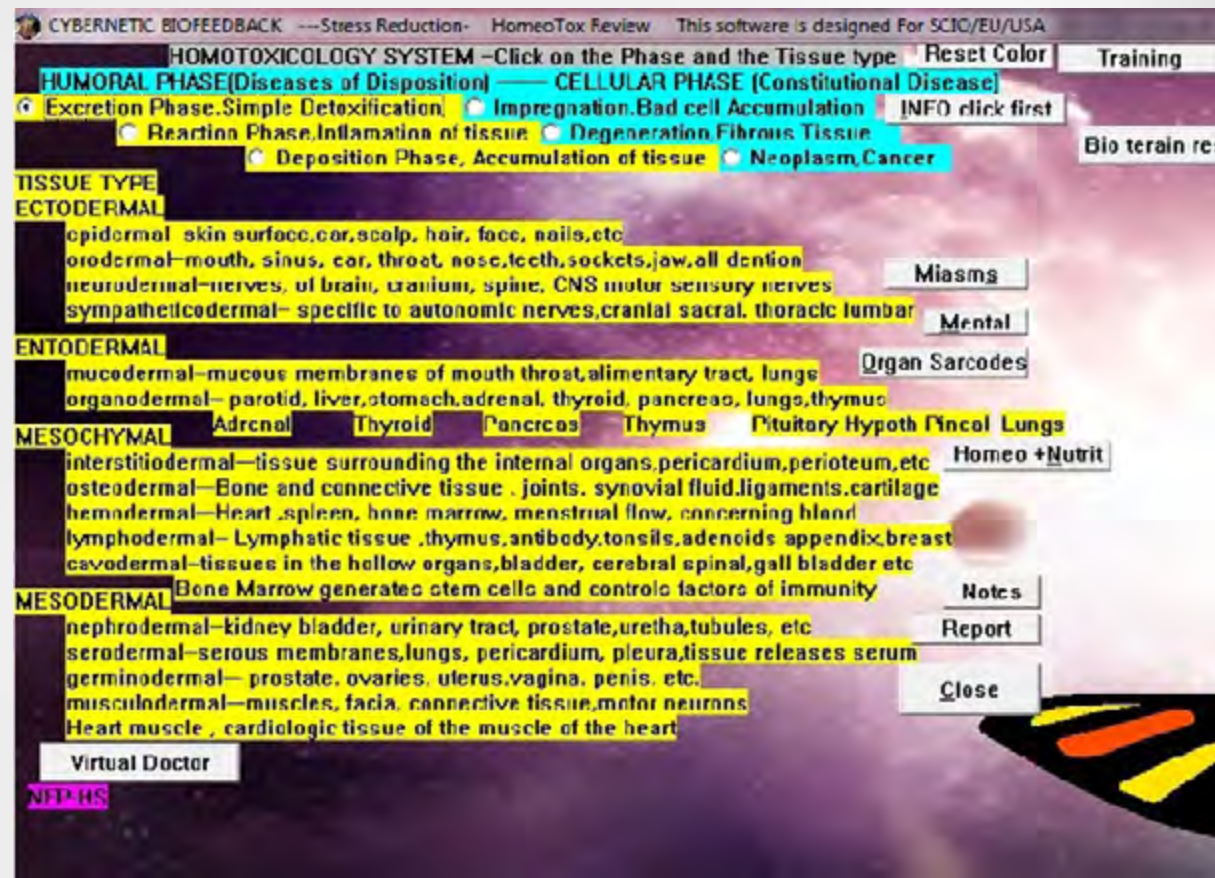

On the top in blue we see the levels of toxicity. First the simple excretion phase, the normal detox of the body. Second an overreaction or excess detox, this produces a symptom. Third then if the toxins are driven back into the body by a dim witted allopath, the toxins go into the interstitial spaces around the cells. Fourth the body impregnates the toxins into the cells, like in the case of liver spots. As the liver gets old or weary and detox is compromised toxins can be put into a liver spot, called so because it comes when the liver is tired of detox. Fifth if the body still can't detox, or if the toxins are driven back into the body by a dim witted allopath, the body makes bad cells and these bad cells are degenerate. Degeneration diseases like arthritis can result. And sixth or lastly the body's final detox is cancer. The last way for the body to detox.

The list in yellow is where tissues where the toxins can be to produce disease. So the homotoxicology deals with the bodies ability to shuffle toxins in an attempt to detox. The sinuses are detoxifiers of the pituitary. The skin is a detox for the thyroid. The lungs for the adrenal. Menses for the female system. You see the body is made with clever ways to detox, lots of back-up systems. All aggravated by suppressive allopathy.

There was once a young girl with a persistent cough in my medical nutrition class in Denver. I was lecturing on Calcium. Calcium is need for muscle action. And if you get deficient in calcium you might get tetany.

Here is the lecture on Tetany: is a medical sign, the involuntary contraction of muscles, caused by diseases and other conditions that increase the action potential frequency. The muscle cramps caused by the disease tetanus are not classified as tetany; rather, they are due to a blocking of the inhibition to the neurons that supply muscles. Low plasma calcium increases the permeability of neuronal membranes to sodium ions, causing a progressive depolarization. This increases the ease with which action potentials can be initiated. If the plasma Ca²⁺ decreases to less than 50% of the normal value of 9.4mg/dl; action potentials may be spontaneously generated, causing contraction of peripheral skeletal muscle.

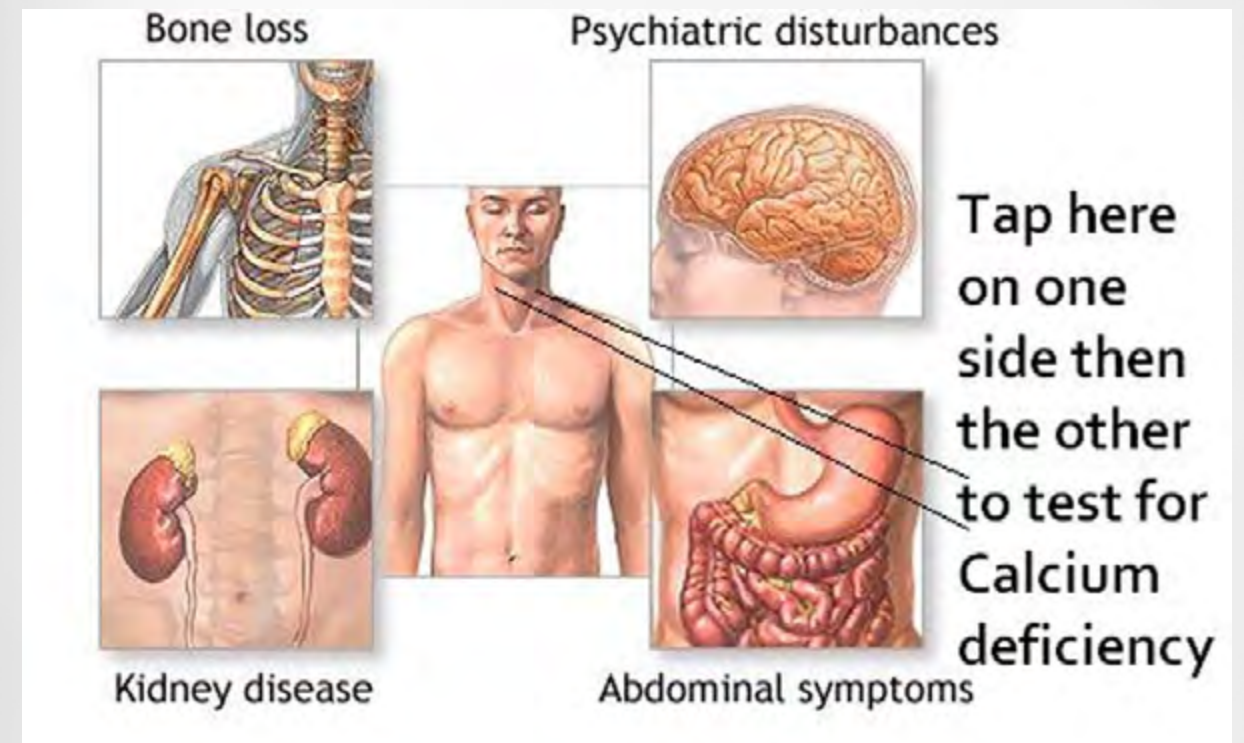

There are many causes of tetany as we can see most of the causes of diseases have nutritional deficiencies and drug interactions at their roots (I put the whole list in detail for you to see just how easily a cough can come from calcium deficiency, and since Calcium is a membrane atom that assists Fatty Acids to make good membranes, and membrane strength is an indication of cancer defense, Calcium deficiency is a cancer risk, the next pages of calcium deficiency are important)(and No milk is not a good source of Calcium, green vegetables are)

So tetany is caused by:

• Low blood calcium levels	• Small bowel resection
• Short/extreme exposure to heat	• Small bowel bypass
• Hypocalcemia	• Chronic alcoholism
• Primary hypoparathyroidism	• Hyperaldosteronism

<ul style="list-style-type: none"> • Secondary hypoparathyroidism, including surgery to the neck, trauma, infection, burns, cancer 	<ul style="list-style-type: none"> • Renal failure
<ul style="list-style-type: none"> • Low Vitamin D, from causes such as malnutrition, malabsorption, kidney disease, infection and drugs 	<ul style="list-style-type: none"> • Alkalosis
<ul style="list-style-type: none"> • Hormone resistance 	<ul style="list-style-type: none"> • Excessive ingestion of alkali
<ul style="list-style-type: none"> • Chelation of calcium 	<ul style="list-style-type: none"> • Frequent vomiting
<ul style="list-style-type: none"> • Low calcium diet 	<ul style="list-style-type: none"> • Hyperventilation
<ul style="list-style-type: none"> • Pregnancy 	<ul style="list-style-type: none"> • Kidney disease
<ul style="list-style-type: none"> • Lactation 	<ul style="list-style-type: none"> • Overbreathing (see Breathing symptoms)
<ul style="list-style-type: none"> • Hypoparathyroidism 	<ul style="list-style-type: none"> • Hypoparathyroidism - causes hypocalcemia
<ul style="list-style-type: none"> • Pseudohypoparathyroidism 	<ul style="list-style-type: none"> • Clostridium tetani
<ul style="list-style-type: none"> • Vitamin D deficiency 	<ul style="list-style-type: none"> • Hyperventilation
<ul style="list-style-type: none"> • Magnesium deficiency 	<ul style="list-style-type: none"> • Hypocalcaemia
<ul style="list-style-type: none"> • Acute pancreatitis 	<ul style="list-style-type: none"> • Hypomagnesemia
<ul style="list-style-type: none"> • Severe diarrhoea 	<ul style="list-style-type: none"> • Strychnine
<ul style="list-style-type: none"> • Malabsorption syndrome 	

The following medical conditions are also some of the possible causes of Tetany. There are likely to be other possible causes, so don't ask your doctor about your symptoms ask about the causes of you symptoms.

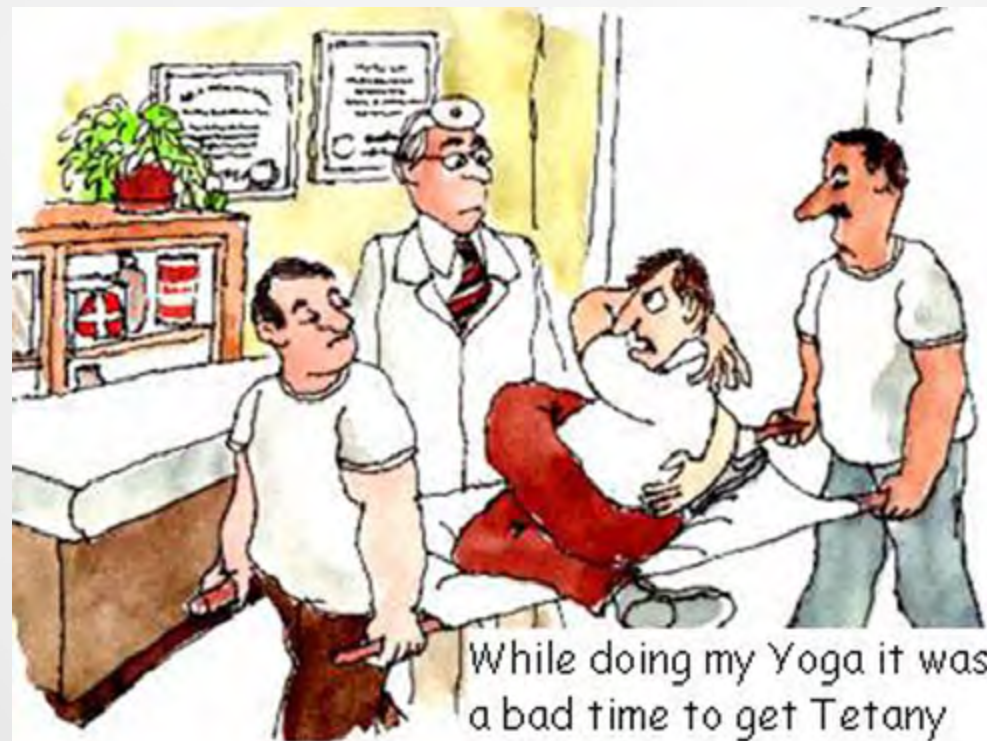

Conditions listing medical symptoms: Tetany A to Z:

A

- **Acid-Base Imbalance ... tetany**

Acid-Base Imbalance: A disruption to the normal acid-base equilibrium in the body. There are four main groups of disorder involving an acid-base imbalance: respiratory acidosis or alkalosis and metabolic acidosis or alkalosis. Obviously the severity of symptoms is determined by the degree of imbalance.

Hypercapnia - metabolic alkalosis

- Dilated brain blood vessels - respiratory acidosis
- Increased pressure inside skull - respiratory acidosis
- Headache - metabolic alkalosis
- Confusion - respiratory alkalosis

B

- **Bartter Syndrome ... tetany**

Bartter Syndrome: A rare genetic disorder of kidney metabolism characterized by reduced blood acidity and low potassium levels.

C

- **Conn's adenoma ... tetany**
- Conn's syndrome ... tetany
- Conn-Louis Carcinoma ... tetany

Conn's adenoma: An uncommon (but possible highly underdiagnosed) condition characterized by the excessive production of a hormone called aldosterone by the adrenal gland. The condition may result from the presence of an adrenal adenoma. The severity of the condition is variable with some patients simply suffering high blood pressure and no other symptoms. Due to the high degree of variation in presenting symptoms, the condition may be frequently underdiagnosed or misdiagnosed. More detailed information about the symptoms, causes, and treatments of Conn's adenoma is available below.

D

- **DiGeorge syndrome ... tetany**

DiGeorge syndrome is rare and is caused by an abnormality of chromosome 22, resulting in a lack of certain genes. This produces a typical group of problems that frequently occur together in DiGeorge syndrome. These include an underactive parathyroid gland (hypoparathyroidism), an underdeveloped or missing thymus gland (hypoplastic thymus), heart defects, and cleft palate and/or cleft lip.

- Drug side effects and interactions
- Synthetic Thyroxine or thyroid pills will supply T3 or T4 but not thyrocalcitonin needed to put calcium into bones this can cause other diseases

E

- Electrocutation ..history of electro shock or other massive electrical current exposure. Tetany

H

- Herbal Agent adverse reaction - Senna too many natural laxatives... tetany
- Hypocalcemia ... tetany
- Hypokalemia ... tetany
- Hypomagnesemia caused by selective magnesium malabsorption ... tetany
- Hypoparathyroidism ... tetany
- Hypoparathyroidism familial isolated ... tetany
- Hypoparathyroidism, autoimmune ... tetany

M

- Magnesium deficiency ... Tetany

O

- Oxalosis ... tetany
- Oxalosis, type I ... tetany
- Oxalosis, Type II ... tetany

Oxalosis: A rare inherited metabolic disorder where excess oxalic acid forms crystals which make up urinary stones. In type I primary hyperoxaluria there is a deficiency of peroxisomal alanine-glyoxalate aminotransferase and type II involves a deficiency of the enzyme glyoxylate reductase/hydroxypyruvate reductase.

R

- Respiratory alkalosis ... tetany

W

- **WDHA syndrome**

A syndrome characterized by Watery Diarrhea, Hypokalemia and Achlorhydria and tetany

Tetanus bacteria has an endotoxin that blocks calcium and cause tetany. The medical test or sign of extreme calcium deficiency is to tap on the parathyroid nerve in the neck. If this produces tetany and spasm of the muscles of the face then there is tetany. Extreme calcium deficiency of over 50%. This is why tetanus bacteria is called lockjaw. It works on the face first often. When you get slightly deficient of 20% the smallest muscle of the body locks up. This is the cilia muscle in the lungs. There are millions of small hairs or cilia on the lung wall. The muscle attached to them use organized motion to sweep the lung clear. We inhale over 25 lbs of dirt a year and without the cilia muscles and process we would develop lung problems. The girl had the persistent cough and I said let's try simple calcium. I gave her two simple pills of a natural calcium lactate. And one hour later she coughed up a small piece of potato chip. She remembered that 2 days ago she was watching a horror show and aspirated a small piece of potato chip. Her body was trying to get rid of it. Her cough then went away. Her cough was merely an alarm reaction to the presence of a toxin.

But what if she was so unlucky, so misfortunate, so ill-fated, so wretchedly miserable star crossed luckless, that she would have went to an Allopath for help?

The allopath would have prescribed a cough suppressant for her cough. The cough would go away and she would adapt to the presence of the chip. The body would try to detox in another way. Her body would surround the chip with a cyst. And try to remove it but as each symptom is suppressed the body will try to make the degenerative cyst grow bigger for easier detox. Then with the addition of another toxin like smoke the cyst could grow cancerous. The final process of the detox. What is the cause of the cancer? Well mindless Allopathy cause millions of cases of cancer each year. When we suppress the symptoms we get problems.

So your cancer might be your body trying to detox. My father developed a cancer on his buttocks. The doctor cut it off and inside was a piece of glass. My dad said he fell on a milk bottle when he was 6 and hid it from his mother. It healed and the body tried and tried to detox finally it made cancer to detox it. Well it worked the doctor cut it free.

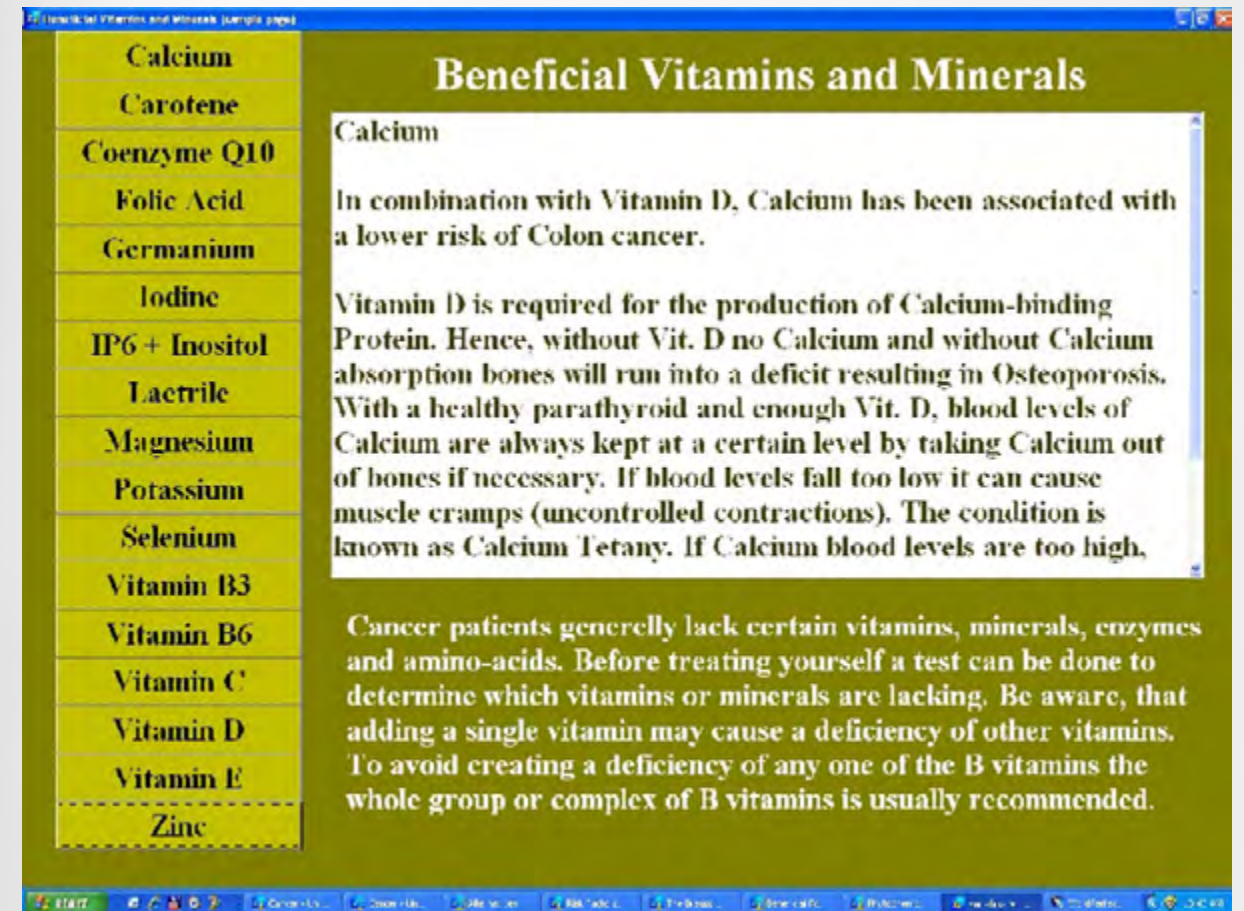

We must first be able to detox then we can get proper nutrition. We cannot enjoy the in breath if we cannot get out the out breath. If we have not urinated in a week we can't enjoy the juice. If we have not had a good bowel movement in a week we can enjoy dinner. We live in a toxic world where detox must be part of our lives.

We need a system of medicine that makes sense and saves lives, not a medicine that makes money.

GunShots Ring out on the Street Again



DID YOU KNOW?

Lean cuts of meat such as chicken breast are lower in salt than processed meats such as ham and bacon. For

Radiation hormesis hypothesis compared with LNT and linear model with threshold. In all 3 graphs, x-axes represent radiation dose and y-axes represent magnitude of health effect. Zero-equivalent point (ZEP) represents level of health effect in absence of radiation. The quadratic model of Figure 1 approximates threshold graph of this figure. A threshold model would imply no effects of radiation up to certain level, after which risk rises linearly with dose. The radiation hormesis model, in contrast, shows beneficial effect at low levels of exposure as it drops below ZEP.

COUNTERTHINK

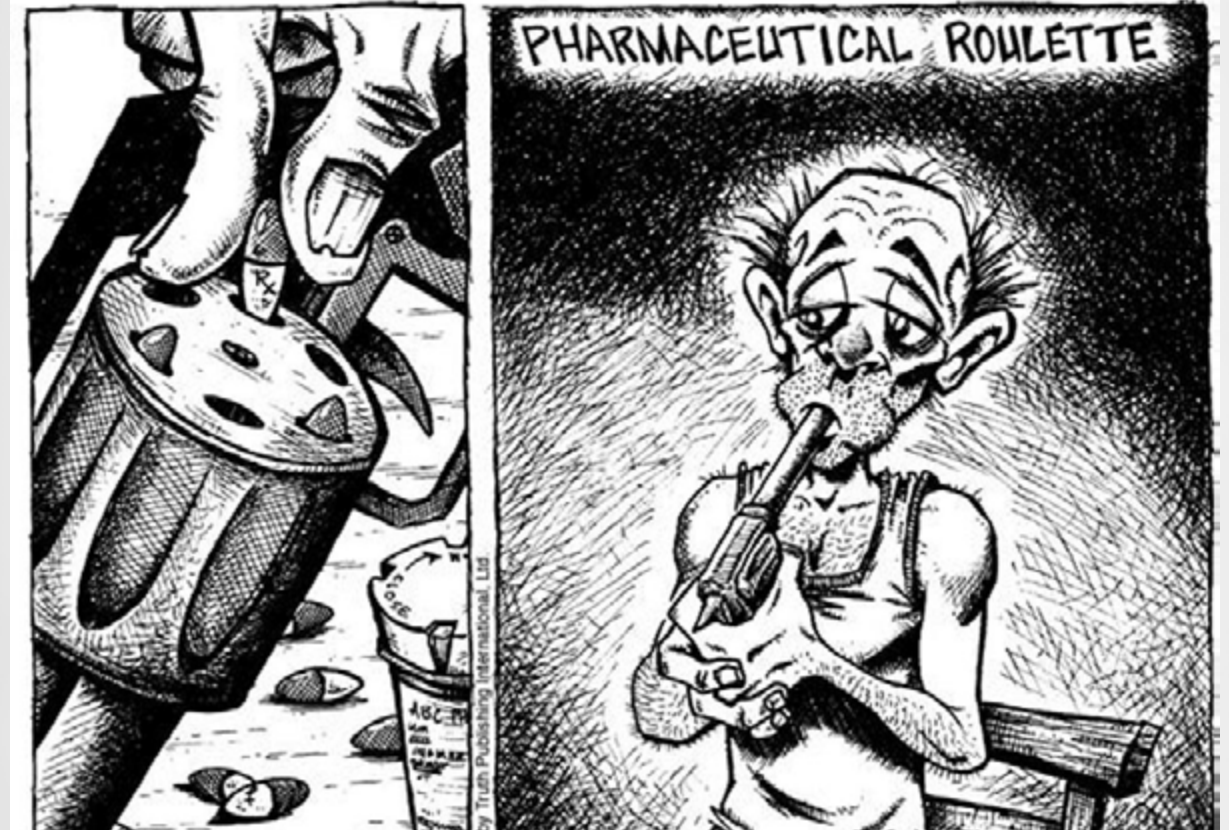

Reckeweg's Homotoxicology Table of Human Adaptation to Toxics

We must first be able to detox then we can get proper nutrition. We cannot enjoy the in breath if we cannot get out the out breath. If we have not urinated in a week we can't enjoy the juice. If we have not had a good bowel movement in a week we can enjoy dinner. We live in a toxic world where detox must be part of our lives.



Figure 2. Dose-response curve showing the quantitative features of hormesis. NOAEL, no observed adverse effect level.

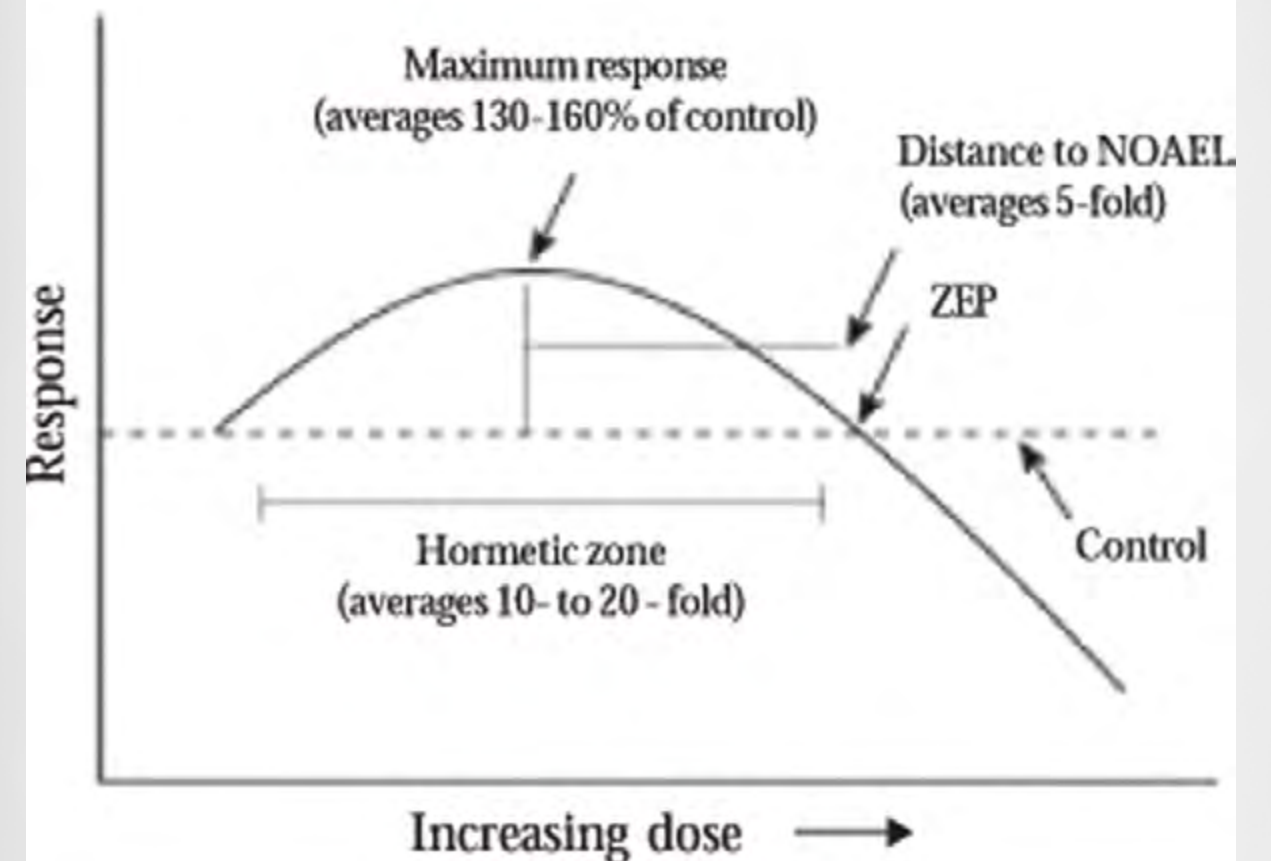

Hormesis (from Greek *hórmēsis* “rapid motion, eagerness,” from ancient Greek *hormáein* “to set in motion, impel, urge on”) is the term for generally-favorable biological responses to low exposures to toxins and other stressors. A pollutant or toxin showing hormesis thus has the opposite effect in small doses as in large doses. A related concept is Mithridatism, which refers to the willful exposure to toxins in an attempt to develop immunity against them.

In toxicology, hormesis is a dose response phenomenon characterized by a low dose stimulation, high dose inhibition, resulting in either a J-shaped or an inverted U-shaped dose response. Such environmental factors that would seem to produce positive responses have also been termed “eustress”.

SIX PHASE TABLE

	HUMORAL PHASES		MATRIX PHASES		CELLULAR PHASES		
Organ system	Excretion Phases	Inflammation Phases	Deposition Phases	BIOLOGICAL DIVISION	Impregnation Phases	Degeneration Phases	Dedifferentation Phases
Skin	Episodes of sweating	Acne	Naevi		Allergy	Scleroderma	Melanoma
Nervous system	Difficulty concentrating	Meningitis	Cerebrosclerosis		Migraine	Alzheimer's disease	Glisarcoma
Sensory system	Tears, otorrhea	Conjunctivitis, otitis media	Chalazion, cholesteatoma		Iridocyclitis, tinnitus	Macular degeneration, anosmia	Arnaurosis, malignant tumor
Locomotor system	Joint pains	Epicondylitis	Exostosis		Chronic rheumatoid arthritis	Spondylosis	Sarcoma, chondroma
Respiratory tract	Cough, expectoration	Bronchitis, acute	Slicceis, smoker's lung		Chronic (obstructive) bronchitis	Bronchiectasia, emphysema	Bronchial carcinoma
Cardiovascular system	Functional heart complaint	Endocarditis, pericarditis, myocarditis	Coronary heart disease		Heart failure	Myocardial infarction	Endothelioma
Gastrointestinal system	Heartburn	Gastroenteritis, gastritis	Hyperplastic gastritis		Chronic gastritis, malabsorption	Atrophic gastritis, liver cirrhosis	Stomach cancer, colon cancer
Urogenital system	Polyuria	Urinary tract infection	Bladder stones, Kidney stones		Chronic urinary tract infection	Renal atrophy	Cancer
Blood	Reticulocytosis	Leucocytosis, suppuration	Polycythaemia, thrombocytosis		Aggregation disturbance	Anemia, thrombocytopenia	Leukemia
Lymph system	Lymphedema	Lymphangitis, tonsillitis, lymphaderitis	Lymph-node swelling		Insufficiency of the lymph system	Fibrosis	Lymphoma, Hodgkin-/non-hodgkin-lymphoma
Metabolism	Electrolyte shift	Lipid metabolism disturbance	Gout, obesity		Metabolic syndrome	Diabetes mellitus	Slow reaction
Hormone system	Globus sensation	Thyroiditis	Goitre, adenoma		Hyperthyroidism, glucose intolerance	Menopausal symptomes	Thyroid cancer
Immune system	Susceptibility to infection	Weak immune system, acute infection	Weak reactions		Autoimmune disease, immunodeficiency, chronic infections	AIDS	Slow reactions
	Alteration*	Reaction*	Fixation*		Chronic Forms*	Deficitis*	Decoupling*
Psyche	Functional psychological disturbance, "nervousness"	Reactive depressive syndromes, hyperkinetic syndrome	Psychosomatic manifestation, neuroses, phobias, neutrotic depression		Endogenous depression, psychosis, anxiety, neurosis, organic psychosyndrome	Schizophrenic defective states, mental deficinecy	Mania, catatoria

The six-phase table is a field matrix reflecting medical experience based on careful observation and empirical learning. It is a phase-by-phase arrangement of disorders with no direct relationship between them. No causal psychogenetic link between disorders can be inferred. The structures of the table makes it suitable for developing a predixtion system giving a better assessment of the possibilities for a vicariation effect.

*Phase nomenclature in psychology.

TABLE OF HOMOTOXICOSES (SIX-PHASE TABLE) Abridged version

	HUMORAL PHASES			MATRIX PHASES			CELLULAR PHASES		
Organ System	Excretion Phases	Inflammation Phases	Deposition Phases	BIOLOGICAL DIVISION	Impregnation Phases	Degeneration Phases	Dedifferentiation Phases		
Skin	Episodes of Sweating	Acne	Nevi		Allergy	Scleroderma	Melanoma		
Nervous System	Difficulty concentrating	Meningitis	Cerebrosclerosis		Migraine	Alzheimer's disease	Gliosarcoma		
Sensory System	Tears, otorrhea	Conjunctivitis, otitis media	Chalazion, cholesteatoma		Iridocyclitis, tinnitus	Macular degeneration, anosmia	Amaurosis, malignant tumor		
Locomotor System	Joint pains	Epicondylitis	Exostosis		Chronic rheumatoid arthritis	Spondylosis	Sarcoma, chondroma		
Respiratory Tract	Cough, expectoration	Bronchitis, acute	Silicosis, smoker's lung		Chronic (obstructive) bronchitis	Bronchiectasia, emphysema	Bronchial carcinoma		
Cardiovascular System	Functional heart complaint	Endocarditis, pericarditis, myocarditis	Coronary heart disease		Heart failure	Myocardial infarction	Endothelioma		
Gastrointestinal System	Heartburn	Gastroenteritis, gastritis	Hyperplastic gastritis		Chronic gastritis, malabsorption	Atrophic gastritis, liver cirrhosis	Stomach cancer, colon cancer		
Urogenital System	Polyuria	Urinary tract infection	Bladder stones, kidney stones		Chronic urinary tract infection	Renal atrophy	Cancer		
Blood	Reticulocytosis	Leucocytosis, suppuration	Polycythemia, thrombocytosis		Aggregation disturbance	Anemia, thrombocytopenia	Leukemia		
Lymph System	Lymphedema	Lymphangitis, tonsillitis, lymphadenitis	Lymph-node swelling		Insufficiency of the lymph system	Fibrosis	Lymphoma, Hodgkin-/ non-Hodgkin lymphoma		
Metabolism	Electrolyte shift	Lipid metabolism, disturbance	Gout, obesity		Metabolic syndrome	Diabetes mellitus	Slow reactions		
Hormone System	Globus sensation	Thyroiditis	Goiter, adenoma		Hyperthyroidism, glucose intolerance	Menopausal symptoms	Thyroid cancer		
Immune System	Susceptibility to infection	Weak immune system, acute infection	Weak reactions		Autoimmune disease, immunodeficiency, chronic infections	AIDS	Slow reactions		
	Alteration*	Reaction*	Fixation*		Chronic Forms*	Deficits*	Decoupling*		
Psyche *Phase nomenclature in psychology	Functional psychological disturbance, "nervousness"	Reactive depressive syndromes, hyperkinetic syndrome	Psychosomatic manifestation, neuroses, phobias, neurotic depression		Endogenous depression, psychoses, anxiety neurosis, organic psychosyndrome	Schizophrenic defective states, mental deficiency	Mania, catatonia		

The six-phase table is a field matrix reflecting medical experience based on careful observation and empirical learning. It is a phase-by-phase arrangement of disorders with no direct relationship between them. No causal pathogenetic link between disorders can be inferred. The structure of the table makes it suitable for developing a prediction system giving a better assessment of the possibilities for a vicariation effect. From the International Society of Homotoxicology, Biologische Heilmittel Heel GmbH. Adapted from <http://www.homotoxicology.net/Documents/biotherapy.pdf>

Homotoxicology differs from Classic Homeopathy

While homeopathy uses single remedy, antihomotoxic medications represent synergistic combination of herbal, mineral, biological, pharmaceutical and/or biopharmaceutical ingredients prepared homeopathically since several tissue-incompatible substances are usually involved during the disease development.

While with homeopathic remedies stronger therapeutic effect is produced with the highest dilutions, antihomotoxic medicines are always prepared in low and medium homeopathic dilutions with D12 dilution being the accepted borderline.

While homeopathic therapy is based on symptoms, antihomotoxic medicine usually follows an indication-oriented approach.

Homotoxicology, as integrated holistic bio-regulatory system of medicine, also differs from conventional medicine by making the PATIENT, rather than the signs and symptoms of the condition, the main focus of interest.

Homotoxicology sees any illness occurrence due to the accumulation of homotoxins in the body, whether of external or internal origin.

- external (exogenous) homotoxins are introduced from external sources due to environmental pollution or poor life style habits. We live in a world surrounded by toxins. Every year, about 1000 new chemicals are released on the market, many not fully tested for their effects on the human body. Some are so called PBTs or Persistent Bioaccumulative Toxins, meaning that they are present in the environment and in our food chain for a long time. These are substances such as pesticide residues (e.g. DDT), polychlorinated biphenyls (PCBs), dioxins and plasticizers. Other more common exogenous toxins include food additives, chemical ingredients used in body care products, cigarette smoke, etc.
- internal (endogenous) homotoxins originate in the body itself as end products of our metabolism, such as histamine, adrenalin etc.; or as result of mutated genes malfunction; or genetic polymorphism in combination with unsuitable life style (e.g. Coeliac disease has genetic predisposition factor but will only develop if the person subjects themselves to the consumption of gluten containing foods, hence 'you are what you eat').

When accumulated in the body, the effects of homotoxins range from immunotoxicity to endocrine disruption and may also affect the nervous system, vital organs, cellular respiration, antioxidant reactions as well as mucosal surfaces. Some may even be carcinogenic.

The anti-homotoxic therapy focuses on ground system (extracellular matrix which plus cellular, humoral and nervous components), the first site for homotoxins deposition which also serves as a site for intercellular communications and immunological reactions (see picture below).



Our teenagers don't
have their own goals



Ground System

The extracellular matrix (ECM, which forms a part of connective tissue) represents a combination of collagens, non-collagenous glycoproteins, and proteoglycans (ground substance) surrounding cells of the connective tissue. Epithelial and non-epithelial cells have receptors (transmembrane family of integrin proteins) with binding affinity to ECM constituents such as cell-adhesion molecules fibronectins and laminins.

Fibroblast is the metabolically active regulation centre corresponding to a glial cell of CNS (Central Nervous System). Fibroblast reacts immediately to all incoming information such as hormones, neurotransmitters, catabolites, metabolites, pH changes etc. and synthesises the matrix substances to suit the current situation within the ECM. Fibroblasts can not differ between bad or good information

Proteoglycans (PGs) are major components of the ECM and consist of a core protein, covalently linked via linker proteins glycosaminoglycans (GAGs, or formerly mucopolysaccharides). Hyaluronic acid backbone is non-covalently linked to core proteins thus forming Proteoglycan aggregate:

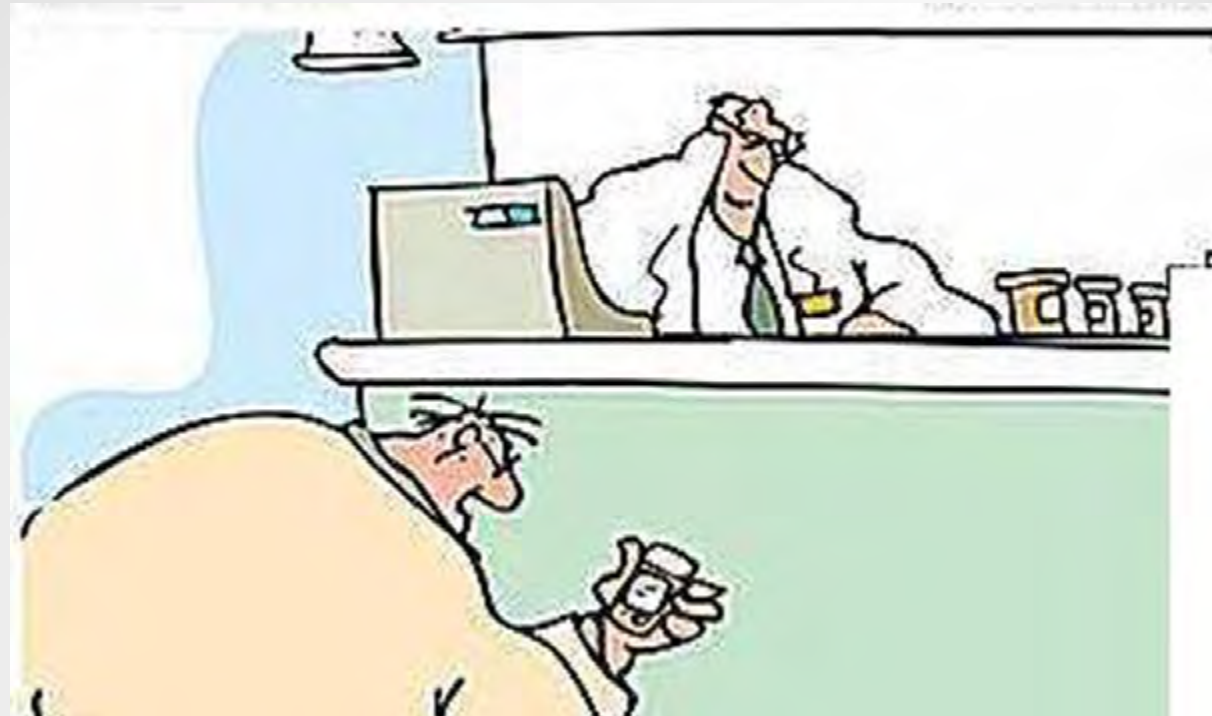

Proteoglycan Aggregate

PGs and GAGs are negatively-charged and therefore are able to bind water via hydrogen bonds formation and exchange ions as well. Therefore they are guarantors for isoionic (removal of any other ions except for those arising from dissociation of solvent and solute), isoosmic (osmotic pressure balancing) and isotonic processes in matrix (tension regulating) processes.

There is reciprocal relationship between capillary system, ground substance, terminal autonomic axons, connective tissue cells (mast cells, fibroblasts etc.) and parenchymal cells (tissue constituting the essential or specialised cells of the organ, e.g. parenchymal cells of liver - hepatocytes). Epithelial and endothelial cell groups rest on the basal membrane which mediates it to the ground substance. Every cell has glycoprotein surface receptors including MHC (major histocompatibility complex) with connections to the ground substance. The ground substance is connected with endocrine system via capillary system, and with central nervous system via axons. And both the CNS and ES are connected to each other via brainstem and overlaid brain centres.

Due to the sieving well as connective properties of the ground substance (PG/PGA), the matrix can become sluggish through development of latent tissue acidity, free radicals increase and trigger of proteolytic degradation processes leading to pro-inflammatory situation. Eventually, damage to all humoral and cellular components may be a result of progression from the feelings ill health to chronic diseases and malignant processes.

The Ground Regulation is regulation of the ground system along with superimposed nervous, hormonal and humoral (related to the blood or body fluids) regulation systems. The system of Ground Regulation constitutes the scientific basis of bio-regulatory medicine.



All reactions in the living organism occur at relatively low temperatures in the aqueous media, therefore they must be accelerated, i.e. catalyzed. The prerequisite for an effective catalysis is availability of suitable substrates within the cells and within intracellular space. As the cells are in direct contact with extracellular space, they can only react to the signals coming via the extracellular space. Therefore the dynamic structure of extracellular space and its regulation ('GROUND REGULATION') have a decisive impact on the effectiveness of extracellular and intracellular catalysts. This depends on the structure of the ECM. ECM forms a molecular sieve of matrix components in all cell groups.

Both Reckeweg's homotoxin theory and antihomotoxic therapy with homeopathic single and combination remedies are based on humoral pathology, that is, Reckeweg saw the organism as a fluid system in the humoropathological sense. Tolerated substances produce no disturbances in the body's steady state, while toxic substances trigger defensive measures that are perceived as illness.

One of the fundamental concepts of homotoxin theory is that all manifestations of life, whether physiological or pathological, are subject to the laws of chemistry.

Metabolic reactions need to occur in a proper environment, free of waste materials and within an ideal pH range. When there is a build-up of toxins in certain areas of the body, the natural chemical reactions become slower and of poorer quality, which in turn, can affect all of the body's functions.

As the quantity of toxins increases, the reactivity potential (natural defence mechanisms) of the individual decreases and the body's capacity to detoxify itself is lessened or even hindered. Thus, this may translate into an evolution of pathologies towards irreversible stages where they become chronic, degenerative or out of control (neoplasm). Many diseases that may then appear are directly related to the body's incapacity to rid itself of its toxins.



Dr Hans Reckeweg worked with Dr. Nelson who made Reckeweg remedies 83 thru 95

Dr. Reckeweg's Six Phase Table of disease evolution illustrates the chronological courses of various symptoms of disease within the structure of the ground regulation. The table is subdivided into three sections: (humoral phases, matrix phases, cellular phases), each of which is subdivided into 2 phases. Each two phases are allocated to the excretion principle (phase 1+2); the deposition principle (phase 3+4); and the degeneration principle (phases 5+6).

Thus 3 main phases of disease evolution depend on the location of homotoxins which can be located:

1. Within body fluids (the associated phase of disease is called HUMORAL, e.g. heart burn, gastritis) – these are the easiest to eliminate, sometimes even detox dieting may help. Inflammation (which is a cyclical process) is referred to a Humoral phase and could serve as a trigger point for further disease development within the Matrix phase if not dealt with properly and/or in time.
2. Within connective tissue (the associated phase of disease is called MATRIX phase, e.g. IBS,

gastric ulcers) – these are more difficult to eliminate and specific remedies are required.

3. Within the cells of tissue (the associated phase of diseases is called CELLULAR phase, e.g. Crohn's disease, gastric cancer) – these are the most difficult to eliminate, requiring application of specific protocols that include enhancement of the cellular metabolic pathway and cellular respiration (Krebs cycle).

HUMORAL PHASES		MATRIX PHASES		CELLULAR PHASES			
Excretion phase	Reaction phase	Deposition phase	BIOLOGICAL DIVISION	Impregnation phase	Degeneration phase	Dedifferentiation phase	
	REGRESSIVE VICARIATION						
						PROGRESSIVE VICARIATION	

When there is a build-up of homotoxins in certain areas of the body, the natural chemical reactions become slower and of poorer quality, which in turn, can affect all of the body's functions. As the quantity of toxins increases, the reactivity potential (natural defence mechanisms) of the individual decreases and the body's capacity to detoxify itself is lessened or even hindered. Thus, this may translate into an evolution of pathologies towards irreversible stages where they become chronic, degenerative or out of control (neoplasm). Many diseases that may then appear are directly related to the body's incapacity to rid itself of its toxins.

Regulation/Compensation division (formerly Biological division) – imaginary boundary between the deposition and impregnation phases. It separates the pure deposition in the matrix from integration of toxins into its structural components. Whereas excretion of toxins is possible in deposition phase, structural and functional changes are found in impregnation phase. Thus spontaneous endogenous excretion of homotoxins is suppressed.

Vicariation – transition of the indicating signs of illness within one phase to another organ system (comorbid conditions appearance), or the transition of fundamental symptoms and signs into another phase within the same organ system.

- Progressive vicariation – aggravation of total symptoms and signs of illness (disease progression).
- Regressive vicariation – improvement of the total symptoms and signs of illness (recovery).



The Greater Defence System

In the human or animal body there is a sophisticated system of interconnected defensive mechanisms that eliminates toxins and repair damage. With the help of these mechanisms homotoxins are either eliminated or combined with other substances to form harmless compounds called homotoxons. This entire system of detoxification mechanisms in Homotoxicology is called The Greater Defence System. It consists of five subsystems:

1. Reticuloendothelial system (humoral defences):

- storage of poisons
- antibody formation

2. Adenohypophyseal-suprarenal-cortex defensive subsystem (humoral defences):

- regulation of suprarenal gland cortex
- connective tissue stimulation
- inflammation arrest

3. Neural reflexes (neural defences)

- excitation or irritation syndrome
- neural therapy
- acupuncture

4. Detoxification in the liver (humoral defences)

- acid linkage
- toxin storage
- neutralising to homotoxons
- properdin system

5. Connective tissue detoxification function (humoral and cellular defences)

- storage of toxins

- antibody to antigen binding
- inflammation
- leucocytes formation
- lymphocyte and macrophage mediated defences

Homotoxicology treats illnesses by detoxifying the affected organs and systems using specific complex medicines combining homeopathic and pharmaceutical ingredients in very low concentrations prepared homeopathically. For example, homeopathic pulsatilla and sulphur are combined together with homeopathically diluted cortisone in one formulation which allows correction of certain type of regulation rigidity in a cyclic process of inflammation. These medicines are available in the U.K. in the form of tablets, drops, creams, gels and ampoules only on prescription from a registered homotoxicologist.



The therapy in Homotoxicology is based on THREE PILLARS:

1. DETOXIFICATION AND DRAINAGE (binding of free radicals, trace elements and mineral balance)
2. IMMUNOMODULATION (Immunological Bystander reaction or Type IV hypersensitivity reaction)
3. CELLULAR ACTIVATION AND ORGAN REGENERATION (cellular respiration, Krebs cycle support)

and organ support with porcine or recombinant proteins)

The Deposition phase and more frequently Impregnation phase is characterised with immunological processes such as chronic inflammation and auto-aggression.

A D1-D14 dilution of antihomotoxic drug contains sufficient amount of substance to stimulate macrophages to produce antigen motif (chain of 9-15 amino acids) after phagocytosis of the whole antigen molecule. This is the prerequisite for production of regulatory lymphocyte Th3 (T-helper cell). The Th3 cells find Th, Th1 and Th2 lymphocytes with similar antigenic motives and suppress them by releasing the anti-inflammatory cytokines TGF- β (transforming growth factor β) and some of the IL-4 and IL-10 (interleukins). TGF- β is the most potent anti-inflammatory cytokine in the body. At the same time the B-lymphocytes are stimulated to elaborate antibodies.



Immunological Bystander Reaction diagram

It is important here to note that production of Th3 cells can take place only in the low-dose antigen range (i.e. from D1 to D14). Greater antigenic protein concentrations inhibit formation of Th3 cells, and high dilutions do not allow for the production of motifs.

Antihomotoxic drugs are particularly suitable for this purpose because due to its animal or other heterologous protein content in dilution between D1 and D14, they can produce a Bystander Reaction.

The other potentiated substances in antihomotoxic drugs are useful for maintaining basic regulation.

The field of medicine these days experiences a shift from devastating infectious diseases to chronic and degenerative disorders. In 1990 the proportion of chronic to acute disease was 1:1 – today it is 9:1.

While acute illnesses are successfully treated with pharmaceutical drugs, the best therapy for

chronic illnesses lies within holistic biological medicine. Biological therapy does not strive for a collision with the proven conventional therapy forms. It is performed additionally and complementarily.

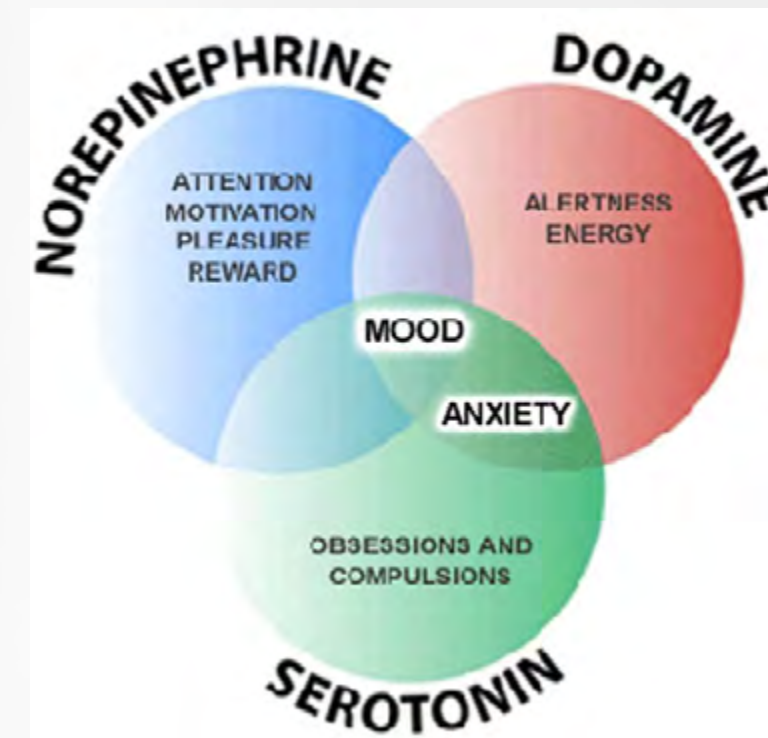

Anti-homotoxic therapy is being used successfully in:

- Chronic and degenerative conditions such as acne, arthritis, asthma, cataract, eczema, IBS etc
- Unstrained weight loss programme
- Preconception detox programme
- Rejuvenation for him and her
- Diabetes and cancer prevention
- Post-chemotherapy recovery programme

Our self-preservation instinct tells us to take care of ourselves. With today's modern technology our longevity is in our hands, and express evaluation of health on the Health Detector scan combined with therapeutic methods of homotoxicology will help you to exert control over this.

References

- Homotoxicology and Ground Regulation System (GRS), by Hartmut Heine. Aurelia-Verlag, 2003
- The Fundamentals of Homotoxicology. Diagnosis and Therapy of homotoxicoses, by Gabriele Herzberger. Aurelia-Verlag, 2003
- Kuby Immunology, W.H. Freeman, 2001
- Color Atlas of Genetics by Georg Thieme et al. University of Essen, 1995

- Biotherapeutic Index, by Biologische Heilmittel Heel, 2000.
- Histology and Cell Biology, by Abraham L. Kierszenbaum. Mosby, 2002
- Oxford Dictionary of Biochemistry and Molecular Biology. Oxford University Press, 2001
- Stedman' Medical Dictionary, 5th edition. Lippincott Williams & Wilkins, 2005



About Quantum Biofeedback

The revolutionary EPFX-SCIO Biofeedback Device was created by Professor Bill Nelson of Hungary over a period of many years of research and development to combine holistic medicine with advanced quantum technology. The SCIO biofeedback device makes it possible to query the body for its most acute and chronic conditions or needs and attempt to balance or correct these stressors with focused energetic therapy.

The main premises of quantum biofeedback therapy are that the body is electrical in nature, that it is innately intelligent, that it has the ability to heal itself if the right conditions or stimuli are provided, and that as the client becomes more aware of that which has been unknown to them, they can make changes to improve their wellness.

The EPFX-SCIO scans the body for 9000 frequencies, each associated with a different compound, much as anti-virus software would do for a computer. The EPFX-SCIO operates at biological speeds (up to 1/1000 of a second) charting the resonance or response of the body to these frequencies, comparing them to a norm and ranking them in degree of reactivity, identifying both acute and chronic imbalances. Clients can then be provided information about the results and energetic therapy can be given to attempt a balancing or harmonizing of any aberrant frequencies. Offering over 200 biofeedback therapies in 72 modalities, it is the largest healthcare software package in the world, combining both eastern and western philosophies and techniques.

Quantum Biofeedback equipment includes a laptop, the EPFX-SCIO, head harness, and limb straps.

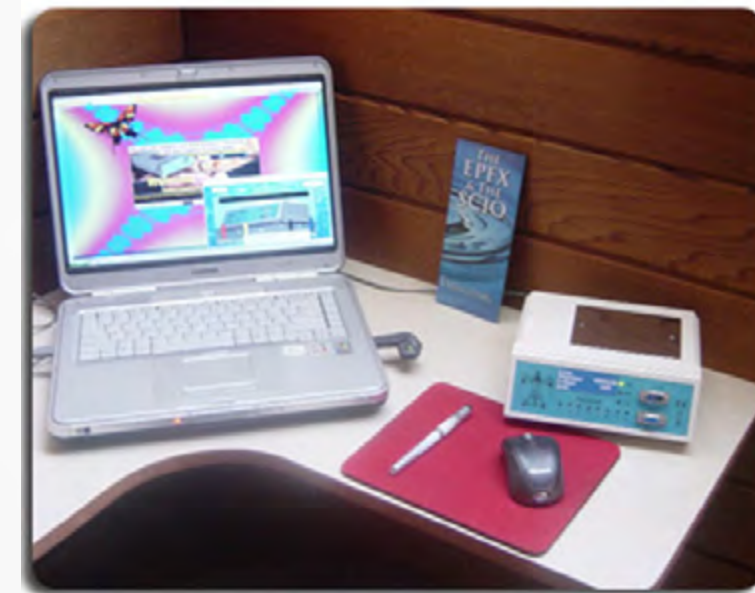

Modalities include:

- Chiropractic
- Electro-acupuncture
- AutoRife
- Dental
- Hololinguistic

- Neurolinguistic
- Homotoxicology
- Homeopathy
- Colour Therapy
- Scalar Therapy
- Darkfield blood analysis
- Electro-hypnosis
- EEG
- ECG
- Cranial Sacral
- Reflexology
- Biofeedback
- Nutrition
- and much more.

The EFPX-SCIO does not replace other forms of alternative healing or a doctor's care, but rather complements them by assisting the body to heal itself naturally and reducing or removing stressors, which contribute to illness. People suffering from the following conditions often respond well to stress reduction with the EFPX-SCIO:

- Attention Deficit Disorder (ADD)
- Addictions*
- Anxiety*
- Arthritis
- Back Pain
- Chronic Fatigue
- Chronic Pain
- Depression*
- Eating disorders
- Immune disorders
- Incontinence
- Infections
- Insomnia*
- Learning Disabilities
- Physical Injuries

- Headaches*
- Hypertension
- Migraine
- Neuralgia
- Unintentional Weight Loss*

Denotes areas of special interest to Trevor and/or personal success with biofeedback stress reduction for clients with these conditions.

A Typical Session

An initial session with the EFPX-SCIO takes approximately two hours, which allows for the completion of the intake form as well as the Suppression and Obstruction to Cure or "SOC" panel, which identifies lifestyle issues and medical history and helps cue the biofeedback device to any particular risks for the client. It is an overall value calculated by the device to reflect the client's impediment to healing. The lower the score, the fewer impediments to healing. Once the SOC panel is completed, the client is connected to the EFPX-SCIO with a head harness and limb straps. The device is then calibrated and the test scan proceeds for about four minutes, measuring the resonance or response of the body to the 9000 items (including minerals, vitamins, toxins, allergens, viruses, pathogens, organ functions, etc.).

When the test is complete, the practitioner reviews the highest risk items and begins to attempt correction of priority conditions. This process usually begins with balancing of minerals, vitamins, and organs to better enable the body to begin healing. The more specialized therapies can then be utilized as appropriate and a strategy for future sessions can be developed in consultation with the client.



Follow-up sessions are approximately one hour and involve a review of the "SOC" panel to determine if there have been any lifestyle or symptom changes to report. Once this is accomplished, the session proceeds as before, continuing therapy according to the client's needs and the wellness plan established after the first session.

Interested in a career in Stress Management using Quantum Biofeedback? Would you like to

know how to purchase your own SCIO or INDIGO?

All SCIO and INDIGO biofeedback devices are available with full training scholarships so that you can get started right away, working with yourself and family or building an exciting career if you choose to become a professional.

What does the SCIO and INDIGO cost to purchase? The cost in US dollars is \$22,000 to \$25,000 depending on which device and the level of training you prefer.

For more information, please contact Trevor directly by phone or e-mail so that he can discuss your needs, arrange a demonstration, and assist you with a purchase.

Disclaimer

No claims are made of the EPM-SCIO system or its results and nothing that the SCIO Practitioner does, diagnoses or treats any illness or disease nor replaces any other treatment. Please consult your family medical doctor for the diagnosis or treatment of disease. Please also consult your family medical doctor before undertaking any health program.

Hormesis

A very low dose of a chemical agent may trigger from an organism the opposite response to a very high dose.

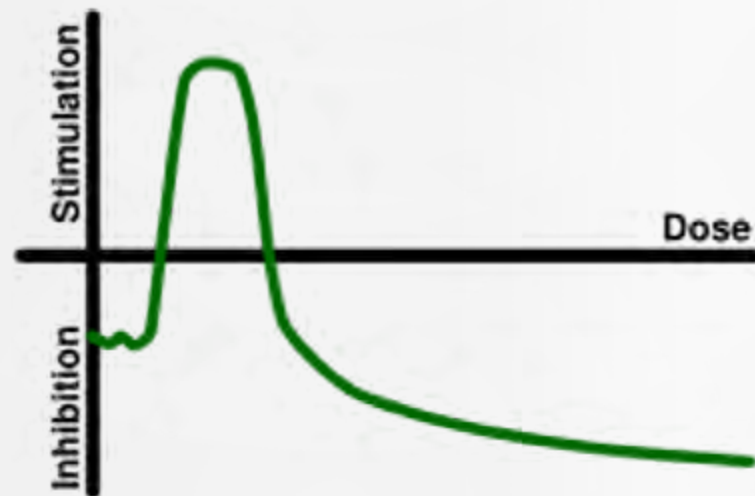

Hormesis (from Greek *hórmēsis* "rapid motion, eagerness," from ancient Greek *hormáein* "to set in motion, impel, urge on") is the term for generally-favorable biological responses to low exposures to toxins and other stressors. A pollutant or toxin showing hormesis thus has the opposite effect in small doses as in large doses. A related concept is Mithridatism, which refers to the willful exposure to toxins in an attempt to develop immunity against them.

In toxicology, hormesis is a dose response phenomenon characterized by a low dose stimulation, high dose inhibition, resulting in either a J-shaped or an inverted U-shaped dose response. Such environmental factors that would seem to produce positive responses have also been termed "eustress".

However, whether hormesis is common or important is controversial. At least one peer-reviewed

article accepts the idea, claiming that over 600 substances show a U-shaped dose-response relationship. Calabrese and Baldwin wrote:

One percent (195 out of 20,285) of the published articles contained 668 dose-response relationships that met the entry criteria.

Indeed, the idea that low dose effects may be (sometimes strikingly) different is accepted, but that the low dose effect is positive is questionable. In one of the better studied areas of hormesis, radiation hormesis the United States National Research Council (part of the National Academy of Sciences), the National Council on Radiation Protection and Measurements (a body commissioned by the United States Congress) and the United Nations Scientific Committee on the Effects of Ionizing Radiation (UNSCEAR) all agree that radiation hormesis is not clearly shown, nor clearly the rule for radiation doses.

The biochemical mechanisms by which hormesis works are not well understood. It is conjectured that low doses of toxins or other stressors might activate the repair mechanisms of the body. The repair process fixes not only the damage caused by the toxin, but also other low-level damage that might have accumulated before without triggering the repair mechanism.

History

German pharmacologist Hugo Schulz first described hormesis in 1888 following his own observations that the growth of yeast could be stimulated by small doses of poisons. This was coupled with the work of German physician Rudolph Arndt, who studied animals given low doses of drugs, eventually giving rise to the Arndt-Schulz rule. Arndt's advocacy of homeopathy contributed to the rule's diminished credibility in the 1920s and 1930s. Recently, Edward Calabrese has revived the hormesis theory through his research on peppermint plants.

Examples of hormesis

There is an extensive body of research that purports to demonstrate a variety of hormetic effects.

Most drugs are toxic when ingested in large quantities. A quantitative measure of this fact is called the therapeutic index. Their beneficial action at correct dosage is not considered an example of hormesis.

Physical exercise

The best known and virtually undisputed example of hormesis is physical exercise. Complete lack of physical activity is associated with increased incidence of a variety of diseases. Excessive exercise is also harmful. Moderately intensive, regular exercise has many beneficial effects, including improved function of the cardiovascular and immune systems. This relationship, characterized by positive effects at an intermediate dose of the stressor, is characteristic of hormesis.

Alcohol

Alcoholic beverages are believed to be hormetic in preventing heart disease and stroke, although the benefits of light drinking may have been exaggerated.

Methylmercury and mallard eggs

In 2010, a paper published in the journal *Environmental Toxicology & Chemistry* showed that low doses of methylmercury, a potent neurotoxic pollutant, improved the hatching rate of mallard

eggs. The author of the study, Gary Heinz, who led the study for the U.S. Geological Survey at the Patuxent Wildlife Research Center in Beltsville, Md., stated that other explanations are possible. For instance, it possible that the flock he studied might have harbored some low, subclinical infection and that mercury, well known to be antimicrobial, might have killed the infection that otherwise hurt reproduction in the untreated birds.

Hormetic effects in aging

One of the areas where the concept of hormesis has been explored extensively with respect to its applicability is aging. Since the basic survival capacity of any biological system depends on its homeodynamic (homeostatic) ability, biogerontologists proposed that exposing cells and organisms to mild stress should result in the adaptive or hormetic response with various biological benefits. This idea has now gathered a large body of supportive evidence showing that repetitive mild stress exposure has anti-aging effects. Exercise is a paradigm for hormesis in this respect. Some of the mild stresses used for such studies on the application of hormesis in aging research and interventions are heat shock, irradiation, prooxidants, hypergravity and food restriction. Some other natural and synthetic molecules, such as celasterols from medicinal herbs and curcumin from the spice turmeric have also been found to have hormetic beneficial effects. Such compounds which bring about their health beneficial effects by stimulating or by modulating stress response pathways in cells have been termed "hormetins".. Hormetic interventions have also been proposed at the clinical level, with a variety of stimuli, challenges and stressful actions, that aim to increase the dynamical complexity of the biological systems in humans.

Mitochondrial hormesis

Hormesis may also be induced by endogenously produced, potentially toxic agents. For example, mitochondria consume oxygen which generates free radicals (reactive oxygen species) as an inevitable by-product. It was previously proposed on a hypothetical basis that such free radicals may induce an endogenous response culminating in increased defense capacity against exogenous radicals (and possibly other toxic compounds).

Recent experimental evidence strongly suggests that this is indeed the case, and that such induction of endogenous free radical production extends life span of a model organism. Most importantly, this induction of life span is prevented by antioxidants, providing direct evidence that toxic radicals may mitohormetically exert life extending and health promoting effects. Since mitochondrial activity was found to be increased in the before-mentioned studies, this effect cannot be explained by an excess of free radicals that might mark mitochondria for destruction by lysosomes, and that the free radicals act as a signal within the cell indicating which mitochondria are ready for destruction, as proposed by Nick Lane.

Another study on yeasts explains the underlying mechanism of the process that prevents cellular damage by reactive oxygen species. Whether this concept applies to humans remains to be shown, although recent epidemiological findings support the process of mitohormesis, and even suggest that some antioxidant supplements may increase disease prevalence in humans.

Controversy as this proves Homeopathy

The hormesis model of dose response is vigorously debated. The notion that hormesis is a widespread or important phenomenon in biological systems is not widely accepted.

The hypothesis of hormesis has generated the most controversy when applied to ionizing radiation. This theory is called radiation hormesis. The commonly accepted model of dose response in radiobiology is the linear no-threshold model (LNT), which assumes a strictly linear dependence between the risk of radiation-induced adverse health effects and radiation dose.

A report commissioned French National Academy concluded that there is sufficient evidence for hormesis occurring at low doses that LNT should be reconsidered as the methodology used to estimate risks from low level sources of radiation, like deep geological repositories for nuclear waste. On the other hand, the United States-based National Council on Radiation Protection and Measurements states that there is insufficient evidence for radiation hormesis and that radiation protection authorities should continue to apply the LNT model for purposes of risk estimation.

Policy consequences

Regulatory agencies such as the Environmental Protection Agency (EPA), the Food and Drug Administration (FDA), and the Nuclear Regulatory Commission (NRC) traditionally use a linear no-threshold model for carcinogens (including radiation). In the linear model, the assumption is that there is no dosage that has no risk of causing cancer. While this linear approach remains the default, with sufficient mechanistic evidence suggesting a non-linear dose-response, EPA allows for the derivation of a threshold dose (a.k.a reference dose) below which it is assumed that there is no risk for cancer.

While proponents of hormesis argue that changing to a hormesis model would likely change exposure standards for these toxicants in air, water, food and soil, making the standards less strict, other scientists point out that low dose stimulation can have extremely adverse effects. For example, research by Retha Newbold at the US National Institute of Environmental Health Sciences has shown that while relatively high doses of a xenobiotic estrogen, diethylstilbestrol, during fetal development cause weight loss in adulthood, extremely low doses cause grotesque obesity. [citation needed] Similarly, low doses of the phthalate DEHP cause increased allergic responses to allergens, while higher doses have no effect. Low dose stimulation can have profoundly adverse consequences. Wider use of the hormesis model would affect how scientists design and conduct studies and the selection of models that estimate risk. In all likelihood, recognizing that low dose effects can't be predicted from high dose experiments would force a strengthening of public health standards, not their weakening, as hormesis proponents would argue.

References

- EJ, Baldwin LA (Aug 2001). "The frequency of U-shaped dose responses in the toxicological literature". *Toxicol Sci.* 62 (2): 330–8. doi:10.1093/toxsci/62.2.330. PMID 11452146.
- Health Risks from Exposure to Low Levels of Ionizing Radiation: BEIR VII Phase 2
- NCRP Store - Add Product to Cart
- Kaiser Jocelyn (2003). "HORMESIS: Sipping From a Poisoned Chalice". *Science* 302 (5644): 376–379. doi:10.1126/science.302.5644.376. PMID 14563981.
- Calabrese, Edward (2004). "Hormesis: a revolution in toxicology, risk assessment and medicine".

EMBO 5: S37–S40. doi:10.1038/sj.embor.7400222. PMID 15459733.

- Bethell, Tom (2005). *The Politically Incorrect Guide to Science*. USA: Regnery Publishing. pp. 58–61. ISBN 089526031X.
- Zsolt Radak; Hae Y. Chung; Erika Koltai; Albert W. Taylor; Sataro Goto (January 2008). "Exercise, oxidative stress and hormesis". *Ageing Research Reviews* 7 (1): 34–42. doi:10.1016/j.arr.2007.04.004. PMID 17869589.
- Cook, Ralph; Edward J. Calabrese (October 2006). "The Importance of Hormesis to Public Health". *Environmental Health Perspectives*. doi:10.1289/ehp.8606.
- "International study questions health benefits of moderate drinking".
- Heinz, G.H., et al. 2010. Enhanced Reproduction in Mallards Fed a Low Level of Methylmercury: An Apparent Case of Hormesis. *Environmental Toxicology & Chemistry* 29(March):650. DOI: 10.1002/etc.64
- Quoted in the article in *Science News*
- Eric Le Bourg and Suresh Rattan editors: *Mild Stress and Healthy Aging: Applying hormesis in aging research and interventions, 2008* (ISBN 978-1-4020-6868-3)
- Rattan, S.I.S. Principles and practice of hormetic treatment of aging and age-related diseases. *Human and Experimental Toxicology*, 27: 151-154, 2008.
- Rattan, S.I.S. Hormesis in aging. *Ageing Research Reviews*, 7: 63-78, 2008.
- Gems, David; Linda Partridge (2008-03-05). "Stress-Response Hormesis and Aging: "That which Does Not Kill Us Makes Us Stronger"". *Cell Metabolism* 7 (3): 200–203. doi:10.1016/j.cmet.2008.01.001. PMID 18316025.
- Le Bourg and Rattan editors: *Mild Stress and Healthy Aging: Applying hormesis in aging research and interventions, 2008* (ISBN 978-1-4020-6868-3)
- Rattan, S.I.S. Hormesis in aging. *Ageing Research Reviews*, 7: 63-78, 2008.
- Ali, R.E. and Rattan, S.I.S. Curcumin's biphasic hormetic response on proteasome activity and heat shock protein synthesis in human keratinocytes. *Annals of the New York Academy of Sciences* 1067: 394-399, 2006.
- Marios Kyriazis 2005. Clinical anti-aging hormetic strategies. *Rejuvenation Res.* 8(2):96-100
- Kyriazis M. 2003. Practical applications of chaos theory to the modulation of human ageing: nature prefers chaos to regularity. *Biogerontology*. 4(2):75-90
- Tapia, PC (2006). "Sublethal mitochondrial stress with an attendant stoichiometric augmentation of reactive oxygen species may precipitate many of the beneficial alterations in cellular physiology produced by caloric restriction, intermittent fasting, exercise and dietary phytonutrients: "Mitohormesis" for health and vitality.". *Med Hypotheses*. 66 (4): 832–43. doi:10.1016/j.mehy.2005.09.009. PMID 16242247. PubMed listing
- Schulz, Tim J.; Zarse, Kim; Voigt, Anja; Urban, Nadine; Birringer, Marc; Ristow, Michael (2007). "Glucose Restriction Extends *Caenorhabditis elegans* Life Span by Inducing Mitochondrial Respiration and Increasing Oxidative Stress". *Cell Metabolism* 6 (4): 280–293. doi:10.1016/j.

cmet.2007.08.011. PMID 17908557.

- Lane, Nick (November 17, 2006). *Power, Sex, Suicide: Mitochondria and the Meaning of Life*. Oxford University Press. ISBN 0199205647.
- Kelley R, Ideker T (March 30, 2009). "Genome-Wide Fitness and Expression Profiling Implicate Mga2 in Adaptation to Hydrogen Peroxide". *PLoS Genet* 5(5): e1000488 (5): e1000488. doi:10.1371/journal.pgen.1000488. PMID 19503593. PMC 2676504.
- Bjelakovic G, Nikolova D, Gluud L, Simonetti R, Gluud C (2007). "Mortality in Randomized Trials of Antioxidant Supplements for Primary and Secondary Prevention: Systematic Review and Meta-analysis". *JAMA* 297 (8): 842–57. doi:10.1001/jama.297.8.842. PMID 17327526.
- Axelrod, Deborah, MD, et al. "'Hormesis'—An Inappropriate Extrapolation from the Specific to the Universal". *International Journal of Occupational and Environmental Health*, 2004;10:335–339. Retrieved 26-Feb-2006.
- André Aurengo; Dietrich Averbeck; André Bonnin; Bernard Le Guen; Roland Masse; Roger Monier; Maurice Tubiana; Alain-Jacques Valleron et al. (2005-03-30) (PDF). Dose-effect relationships and estimation of the carcinogenic effects of low doses of ionizing radiation. *Académie des Sciences & Académie nationale de Médecine*.
- Evaluation of the linear-nonthreshold dose-response model for radiation protection. NRC. 2001

IMUNE 12 MONTH HOME STUDY COURSE

Go to <http://immune.name> to learn and to get your course materials. You could get a Doctorate in Wellness and an international or accredited European professional qualification in neurophysiological bioresonance and biofeedback.

The Tassel is worth the Hassel. In a world so concerned of Wellness can be yours in just 12 months of Home Stury, a simple thesis, a practicum and four days of monitored supervised contact.

Big Tobacco, Big Sugar, Big Pharma, Big Oil, and Big War Industry are exempt from lay and they kill and injure, maim and cripple in the name of profit. They seek to control and dominate medicine to further build their profits.

Their money controls governments, regulators, and the small minded media. The Ultra Rich Master Echelon Computer now sees and hears all the things we say, write, and do. Rights of privacy are gone worldwide. They have taken away our rights of free speech.

The Ultra Rich control the media and refuse to tell stories that expose or offend the Ultra Rich Power. They control every movie that gets distribution, every song that hits the radio,

everything that is put on the world news. They use science and psychology to control and manipulate the minds of the masses.

But medicine is controlled by Universities that teach medicine. There is now one university starting to defend Natural Medicine. IMUNE has a new 12 month home study course that can be bought with Karma and you can learn how to do natural medicine and how to break free from the Ultra Rich control.



Big Tobacco
 Big Pharma
 Big Sugar
 Big Media
 Big Banking
 Big Money

Well, the game of Reality Monopoly is still being played all over the world. One percent of the world's population is winning and now controls over 80% of the wealth. The law allows the game to continue till we will see one winner and 6 billion plus losers



THE GOLIETHS

Big
Sugar

Big
Tobacco

FDA

Corporate
Music

Big
Pharmaceuticals

Hollywood
Media Mafia



Battle of the Millennia: David Desi vs. Goliaths

by Heather Swanson

There's a battle outside your door, shaking your house. The battle cry has reached your ears; it's raging in them. Only this is between the big guy and the little guy, and you don't think he has a chance. Or are you already getting prepared to live under the big guy for the rest of your life?

We all remember the story of David and Goliath. Well, today, it's not just one Goliath, it's a host of THE GOLIETHS that freely roam the earth victimizing the human race all in the name on greed and money.

So, about now, you are thinking: This is a big fairy tale, right? Let's meet our modern-day corporate Goliaths:

1) Big Sugar. Don't tell me you don't eat it. Dig your teeth into this: white dextrose sugar weakens the immune system and causes obesity. Over consumption of sugar is linked to lethal health problems and terminal illnesses such as diabetes and heart disease and it happens to be one of America's top money makers.

2) Big Tobacco. One in every five deaths in the United States is smoking related. Need we say more? It's legal, socially acceptable, and though a consumable drug (right?) The FDA happens not to be responsible for it.

3) The FDA. A kind of Igor, Frankenstein's assistant, for these Goliaths. A polyspermic agency, which has risen to its Goliath stature by consuming billions of dollars fed to it by pharmaceutical, big sugar, and other bribes. The FDA protects big sugar, big pharmaceuticals, and big tobacco more than it protects the American people.

4) The Music Industry. Think the death of Woodstock and the birth of MTV. Opposing, independent ideas, free creativity and a host of concepts related to freedom of expression, music has become a bloody battle for sales and power for this race of Mega-Poptarts. Its all about hype and nothing about talent.

5) The Pharmaceutical Industry. A multi-billion dollar business, the backbone of current allopathic medicinal practice, a leading cause of death in the USA and a killer of over one million Americans yearly.

6) Hollywood. One consumable that needs no introduction. In America, 99% of homes have at least one television set. In 2004, top studios totaled revenues of \$7.4 billion from world box-office sales,

\$20.9 billion from world video sales, and \$17.7 billion from world television licensing. Hollywood is a media monopoly with no room for protest or true idealism.

Now, meet David...I mean, Desi. Poet, musician, and healer Desiré Dubounet is currently fighting a 6-way battle armed only with her special superpower, clarity of mind, and the SCIO - a biofeedback machine Desiré patented that caught the FDA's attention because it doesn't match their "regular" clients. It's chemical free and doesn't need the FDA to market it because people buy it because it works. In 2002, 785 died from falling over furniture to date, no one has died due to use of the SCIO. So, why don't they go investigate furniture manufacturers?

With her independent media company Change the World Productions, Desiré has been fighting the propaganda that has monopolized multimedia for generations. If you take a trillion dollars and stack them up, they would reach to the moon and back. Well, these trillion dollar industrial Goliaths are pitting themselves against one, solitary individual who has stood up and showed that there is a different way - a better, more noble path to the future betterment of this planet. After all, it isn't an accident that her company is called Change the World Productions. It's Desiré Dubounet's fate.

Take a stand today behind truth and justice: Join Desi in the fight against these malformed modern-day Goliaths that now terrorise our lives.



www.i-am-films.com
www.leftv.com
www.tmttv.com
www.desifm.net
www.theangelofgod.com

SCIO-Bio-Electronic Supported Elimination of Toxic Substances from the Human Body (SCIO Detox)

Developed By:

Authors: Dr. Annamaria Cakó M.D. Budapest, Hungary

Abstract

We are living now in the age of big contradictions. Development of science makes medicine be able to carry out great achievements but in the meantime, lifestyle-dependent diseases outbreak in epidemic growth. There is an ever increasing toxic burden implied on all of our patients. We must detox to survive. Detox is becoming more difficult in an ever increasingly toxic world.

Methods of detoxification have been known for a long time and they revive today. The SCIO has the electronic signatures of thousands of toxins in its repertory. Also the trivector signatures of the detox organs and their hormones. The SCIO can put electronic signals of these signatures into the body for the body electric to guide for increasing the detox abilities of the body. This article reviews the safety of the SCIO and its tremendous assistance to detox in over four hundred patient records. 425 patients are assayed for toxins and retested after the SCIO treatments. The results were astounding.

Key Words: Biofeedback, stress, stress reduction, Detox, Auto-Toxins, Sue-Toxins

© IJMSH 2008

Introduction

This article reviews the clinical results and experiences of users of the SCIO/EPFX biofeedback device after almost six years of medical use in my medical practice in Budapest, Hungary. The practice of biofeedback dates back to the fifties. The technique of using biofeedback devices to diagnose stress and treat stress is receiving more attention in our ever increasingly stressful world. In this article we review the positive results achieved from clinical experience treating patients on a day to day basis.

In over two hundred million patient visits the SCIO/EPFX over the last two decades, the SCIO was is an estimated 80% success rate in reducing stress and assisting many medical procedures. There were no reported significant risks reported during this two decade twenty years of use. The SCIO is proven safe and effective.

Although SCIO biofeedback is an effective clinical procedure, it is not used in isolation from other therapeutic techniques. Since many of its clinical applications focus on the reduction of anxiety or physiological arousal, relaxation procedures have been used with biofeedback to maximize this effect. The patient undergoing biofeedback treatment is often introduced to a relaxation technique prior to receiving biofeedback.

In this article we will concentrate on the results of using the SCIO/EPFX device in a medical clinical setting.

Why is it more important for the man of today to support the elimination of toxic substances from the human body?

We are living now in the age of big contradictions. Development of science makes medicine be able to carry out great achievements but in the meantime, lifestyle-dependent diseases outbreak in epidemic growth. The synthetic chemical industry has produced over 30,000 chemicals that are toxic to the human body at some level. Only three of these have been fully researched to understand their complete environmental picture. We live in an ever increasing toxic sewer. We must detox to live. Everybody makes their own auto-toxins, as excretion is a part of biology and life. Our bodies are ever more toxic and desperately need detoxification. There are two important questions coming up here:

- Is there a perspective in the direction of treating chronic toxic diseases allopathically?
- Do we in every way know the reactions of the human body to clinically apply SCIO methods?

What are toxins and what is detoxification?

An intense Reactive Toxin is a substance that provokes an adverse reaction in the organism immediately or within hours. This can be an inner or an outer response. Detoxification is a natural method supporting increased excretion or elimination of substances of inner or outer source being present in the organism. Thus, we support the excretion of the organism in order to remove accrued excretas, intermediate- and end products of metabolism, needless micro- and macro-elements as well as toxic substances of the outside world. The human body has a very effective ability to detoxicate that is performed by the great detoxicating organs (liver, kidneys, skin) continuously. A common way of detoxication ability of the human body is the transformation of the foreign, exogenous substances (this is the so called bio-transformation). On the one hand, the regulation method/therapy applied by me supports the effectiveness and harmony of this life-function and on the other hand, the relief of either functions becomes possible. The human body needs continuous detoxication that a healthy man can carry out without any further help since his metabolism works optimally. In the course of a healing process the deceased organism often wins over the disease by its inner detoxication mechanisms. Unfortunately, we cannot avoid meeting toxic substances in our environment of today that's why it is important to support their elimination.

Let us give names of some of these items mentioned.

First of all

- toxic heavy metal salts that infiltrate the body
- cadmium in the inner of pork and beef
- lead in the air, fruits, greens, liver and kidney
- mercury in amalgam fillings, in ocean fish
- nickel in bridges made of metal
- nitrate, nitrite and nitroamines in conserving and coloring substances
- radioisotopes

- polycyclic aromatic hydrocarbons at barbecuing and grilling
- volatile hydrocarbons
- washing and cleaning supplies, fabric softeners
- allopathic remedies and their remains
- nutrition additives
- air fresheners, insecticides

Dr. Reckeweg made a point against eating any pig product. The pig does not sweat and thus can not properly detox. These pig toxins are called Suine toxins (Sue toxins). The sue-toxins are responsible for many toxic burden diseases such as arthritis, carbuncles, cancer, boils, skin disease, liver burden.

What symptoms does someone have if his detoxication is insufficient?

Characteristic symptoms, especially when an internal medical check-up's results are negative:

- constipation
- changeable stooling
- urine and sweat of heavy Oder
- bad breath
- constant tympany
- coated tongue, tooth impression in it
- parodontosis, heavy decay
- fatigability, deconcentrationness
- frequent headache
- loss of hair
- unclear skin
- changeable symptoms of allergy

What does the status of toxic balance mean?

A patient at this stage is not sick yet but he has many returning symptoms. His laboratory findings are normal or just minimally differing. To uncover this, regulation therapies, like SCIO, are very effective and they are able to avoid the manifestation of the disease. The patient is still healthy, not classically sick, so prevention still works here.

There is the so called unstable toxic balance when the patient is already sick there are symptoms of disease, there is degeneration in internal medical and laboratory findings (hypertension, blood lipid and sugar at top limit, articular complaints, headache, dermatological symptoms and those of allergy and respiratory system, hormone problems, overweight). The patient regularly takes medication, he does not feel sick yet but there is a feeling of discomfort. Awareness of illness is

rising.

Here we have to mention the Metabolic X Syndrome:

- overweight
- hypertension
- diabetes of II. type
- arteriosclerosis
- gout
- lipidosis

Another factor to mention is the regulation rigidity that we can observe in the case of the chronically ill with degenerative or tumor disease. The regulation process here is complicated and slow. In the case of these patients detoxication would be of high importance but this could reduce the effectiveness of certain treatments like cytostatic remedies and radiation therapy.

Methods and Materials:

How does the SCIO Detox regulation therapy proceed?

The first time, the status of the patient is being tested and recorded with laboratory, inner medical, gynecological, etc. findings. The test includes the level of acidosis, the status of metabolism, inflammation processes in the body, charting allergies as well as the measurement of the energetic reactivity of the organism. Here be decided, what diet the patient should follow, what remedies he is getting (vitamins, osteomolecular remedies, homeopathy, herbal therapy) and how frequently he should get regulation therapy with the SCIO-device.

In the first 3 weeks the patient gets a treatment once a week due to the close control. This is necessary because acidosis at the beginning of the detoxication may temporarily increase; complaints and symptoms may become more intensive. Therefore excretion as well as the immune system need stronger support in this phase and psychic help is also of a high importance.

By the end of the 3. month, 70-80 % of toxic substances can be eliminated with SCIO. This is also visible in the laboratory and ultra sound findings. In the 2. phase of the treatment the bowl flora is supported and the immune system is strengthened. By the end of the 6. month the patients feel themselves more energetic, chronic diseases stop or reduce to a minor level. Liver regeneration is about to start.

The complex therapy applied by me have been used with 350-400 patients with very good results. The average age of the patients makes 45 years; breakdown by sex makes 2/3 of female and 1/3 of male patients.

By the end of the 6. months I can say that the complaints having returned for years ceased, the allergies were gone, 70 % of the patients stopped taking any medication.

Process of the treatment:

1.-3. week: once a week
4.-12. week: every fortnight
last 3 month: once a month

As of the 3. week

fatigability decreases by 80-90 %;

stool is normalized in 90 %;

somnipathy is gone in 100 %;

emotional pattern gets better in 90 %;

laboratory findings get better in 50 %, by the end of the 6. month they normalize in 90 %;

medication intake decreases by degrees, by the end of the 6. month most medication can be omitted in 90 %.

It is important to remark that I do no detoxication under the age of 18 due to the unpredictable reaction since children's organism is very unstable.

Results: How does the regulation therapy proceed?

The first time, the status of the patient is being tested and recorded with laboratory, inner medical, gynecological, etc. findings. The test includes the level of acidosis, the status of metabolism, inflammation processes in the body, charting allergies as well as the measurement of the energetic reactivity of the organism. Here be decided, what diet the patient should follow, what remedies he is getting (vitamins, osteomolecular remedies, homeopathy, herbal therapy) and how frequently he should get regulation therapy with the SCIO-device.

In the first 3 weeks the patient gets a treatment once a week due to the close control. This is necessary because acidosis at the beginning of the detoxication may temporarily increase; complaints and symptoms may become more intensive. Therefore excretion as well as the immune system need stronger support in this phase and psychic help is also of a high importance.

By the end of the 3. month, 70-80 % of toxic substances can be eliminated with SCIO. This is also visible in the laboratory and ultra sound findings. In the 2. phase of the treatment the bowl flora is supported and the immune system is strengthened. By the end of the 6. month the patients feel themselves more energetic, chronic diseases stop or reduce to a minor level. Liver regeneration will start properly after using the SCIO much more reliably.

The complex therapy applied by me have been used with 425 patients to date with very good results. The average age of the patients makes 45 years; breakdown by sex makes 2/3 of female and 1/3 of male patients.

By the end of the 6. months I can say that the complaints having returned for years ceased, the allergies were gone, 70 % of the patients stopped taking any medication.

Process of the treatment:

1.-3. week: once a week
4.-12. week: every fortnight
last 3 month: once a month

As of the 3. week

fatigability decreases by 80-90 %;

stool is normalized in 90 %;

somnipathy is gone in 100 %;

emotional pattern gets better in 90 %;

laboratory findings get better in 50 %, by the end of the 6. month they normalize in 90 %;

medication intake decreases by degrees, by the end of the 6. month most medication can be omitted in 90 %.

It is important to remark that I do no detoxication under the age of 18 due to the unpredictable reaction since children's organism is very unstable.

Discussion:

Stress is a part of all disease pictures and stress reduction should be a part of all medicine. The detox capacities of the human are in operant control of the Parasympathetic nerval system. Thus stress reduction is a factor in detox as well. But the SCIO EMR pulse has profound effects on detox by moving free radicals which have magnetic properties. The cybernetic loop also stimulates the detox system. The SCIO/EPFX or in fact any biofeedback can be helpful for stimulating awareness, control, responsibility ,detox and return of health. The techniques tested in this paper were shown extremely helpful in reducing stress and detox.

In conclusion, the authors views the SCIO/EPFX as an important biofeedback tool useful for detox in many stages of stress reduction-oriented therapy and would encourage allied professionals and regulatory bodies to recognize its value.

Bibliography

1. Mirella Fischer - Williams, M. D., Alfred J. Nigl, David L. Sovine, M. D. Textbook of Biological Feedback, Human Science Press (1981) N. Y.
2. Andreassi, J. L, Psychophysiology: Human Behavior and Physiological Response (1995) (Biofeedback Certification Institute of America)
3. Striefeld, S. Practical Guidelines and Standards for Providers of Biofeedback and Applied Psychophysiological Services (Biofeedback Certification Institute of America)
4. Hatch J. P, Fisher J. G. & Rugh J. D. Biofeedback: Studies in Clinical Efficacy (1987) (American Biotec Corporation)
5. James R. Evans & Andrew Abarbanel ed. Introduction to Quantitative EEG and Neurofeedback

(American Biotec Corporation)

6. Jr. Cram & G. Kasman Introduction to Surface EMG (American Biotec Corporation)
7. Jr. Cram & J. Holtz Intro to Electrode Placement: Strategies for Clinical Applications (American Biotec Corporation)
8. Gaarder, K. & Montgomery, P. S. Clinical Biofeedback: A Procedural Manual (1981)
9. Basmajian, J. V. Biofeedback: Principles and Practice for Clinicians (1989)
10. Loring, D. W. Neuropsychological evaluation in epilepsy surgery. *Epilepsia*, 38. (Suppl. 4) (1997)
11. Meador, K. J. Cognitive and behavioral assessments in antiepileptic drug trials (1998) In J. French, M. Dichter, and I. Leppik (Eds.) Antiepileptic drugdevelopment. *Advances in neurology* (Vol. 76) Philadelphia
12. H. J. Wieringa MEG, EEG and the integration with magnetic resonance (1993)
13. W. C. Nelson Immune, Basic Biofeedback (1995)
14. W. C. Nelson International Journal of Science of Homeopathy: Reactivity (November 1997)
15. W. C. Nelson EAV as Evoked Potential (November 1997)

Appendix 1

Homotoxicology

The body must deal with detox. We must exhale to inhale. We must urinate and defecate. Our skin must sweat and our mucous membranes detox as well. We must cleanse before we nourish. There is a simple fact of biology that no organism can survive in his own waste. Because of this we have been given an instinct to dislike our waste products. These have become some of our swear or taboo words, such as shit, piss, or snot. We scold our children when they discuss these.

As we are exposed to more and more toxins our detox mechanisms of the body are overloaded. This can often produce an excess toxic release. Such as diarrhea, excess sweat, smelly urine, skin conditions, etc. Since we have an instinct to dislike these auto toxins we often see them as symptoms. If we are so unlucky or unwise to then see an allopath, then the allopath will most often fight the symptom, by prescribing a drug that blocks the detox response. Antihistamines block the detox of our sinus, Antipyretics stop the detox of our fevers, Antispasmodics stop the intestinal cleanse, and on and on. The worst drugs are the steroids such as the cortisone creams that stop the skin detox and drive the toxins in deeper. Steroids are the best compounds for fighting detox symptoms.

The German field of homotoxicology shows us how these toxins can build up and start to be deposited into other tissues and eventually cause cancer. The chart on Homotoxicology outlines the process. At the top there are the stages of detox, and down the side we have the tissue types where the toxins can have effects. A field of detoxifying homeopathy has arisen from this observation. By using certain toxins homeopathically we can stimulate detox and correct the allopathic damage. This allows for us to deal with the underlying disease and then clear up the symptoms naturally. The symptoms are just signposts of deeper pathology.

If we use organic toxins we call them nosodes. Nosodes are diseased or disease-causing tissue. If we use synthetic man-made compounds we call them isode or detoxasodes. Often times a synthetic

compound entered into the body is dealt with inappropriately by the liver. The liver makes proteins to bind to the toxins and disable them. If the liver makes an inappropriate protein a new toxin can result. This is called a prion. Prion homeopathics can also help us in treating exposed patients. This allows us to develop a refined arsenal of homeopathic medications for the illnesses of the world.

The use of nosodes, isodes, allersodes, and sarcodes is an ever increasingly popular form of homeopathy around the world. It is gaining in medical popularity daily. This art needs to be responsive to an ever-changing world. As new viruses are developing and genetic variance is continuously changing the entire microorganism field, only a flexible model for development of homeopathics can allow us to respond to new health crises. There are new synthetic compounds developed daily around the world as well.

Appendix 2

General detoxification and prevention

1. **Procure a good source of water.** Ordinary tap water must be double-filtered to remove most chlorine and fluorine. Activated charcoal filters are inexpensive and good (change filters once every 4 months to forestall bacteria buildup). Water processed by reverse osmosis is best, but daily output (on most available units) is limited. Distilled water is not recommended for long-term use because it is "dead" and may chelate and hasten excretion of essential metals. The addition of wetting agents to water makes a water that is helpful for cleansing and healing. Spring water is good, but be sure to have questionable sources checked for pollutants.
2. **Avoid air pollutants.** Make every effort to live and work away from the denser urban areas. If this is not possible, try to get away for several weeks a year (preferably to the mountains or to a clean ocean) to rebuild lung tissue. Use air filters or air ionizers in the home and office. If you exercise outdoors, do it during relatively low-pollution times such as very early in the morning or well after rush hour at night.
3. **Avoid commercialized foods.** Buy produce, grains and other staples from health food stores and co-ops at which the likelihood of obtaining foods grown in good soil is greater; or grow your own in healthy soil. Carefully wash produce from supermarkets: use soapy water or 0.2 ounces hydrochloric acid to 3 quarts of water. Place produce in the water for 5 minutes. Grains, beans, vegetables, fruits, nuts, sprouts and other simple foods are the best dietary staples. They are inexpensive, healthful, tasty, easy to prepare and ecologically sound. Seed products are best when sprouted. Cover with damp cloth for 24 hours, then dry. This washes away enzyme inhibitors.
4. **Curtail the use of chemical sundries in the home.** This includes cleaning fluids, insect repellents, garden sprays, air fresheners, detergents, dry cleaning fluids, etc. Try to obtain natural cleaners and solvents.
5. **Improve your eating style.** This means, in addition to eating the right foods, to avoid overeating (under-eating is best) and eat at the right times. The bulk of the day's food should be eaten before the early afternoon. Avoid big dinners after 6:00 p.m., they do not digest properly. Also, relax before and after meals. If you are upset or very tired, it is best to skip the next meal. Never eat or drink foods or beverages that are very hot or cold. If your hand cannot tolerate the temperature, neither can your stomach. Fluids alone, fruits alone, melons alone. Fresh

and raw should be your guideline.

6. **Exercise!** Everyone needs vigorous exercise - at least 15-20 minutes three times per week, every day is better. Start with an easy program and build up. Jogging and swimming are good, and mini-trampolines are excellent if you are very much out of shape, or need something for indoors during the bad weather.
7. **Embark on a basic supplementation program.** Consult with your doctor and use basic protective food supplements daily. We highly recommend the following products.
 - **“A-Z Formula”:** 2 tablets per day. Provides many trace elements and protective factors not found in ordinary foods. If there is iodine sensitivity, use “A-Z Formula minus Iodine”. “A-Z Mega” may be used for the severely deficient person.
 - **“Amino Acid Mineral Liquescence”:** 2 teaspoons per day. Provides all amino acids and minerals needed for life and detoxification.
 - **“Fatty Acid Liquescence”:** 2 teaspoons per day. This contains all fatty acid components needed for life. Compensates for loss of nutrients from hybridization and cooking.
 - **“Phosphatidyl Choline”:** 1-2 tablets per day. Provides essential fatty acids and helps keep cholesterol under control, while stimulating brain performance.
 - **Yogurt:** 1-2 cups per day (or use buttermilk, kefir, etc.). These fermented dairy products provide beneficial bacteria for colon health.
 - **“B-Complex” and “Brain Liquescence”:** 1-2 teaspoons per day (use a natural RDA potency). Amounts above what can be obtained from food have preventive and protective value. Also “A-Z Formula”, “A-Z Formula minus Iodine”, or “A-Z Mega” in severe nutritional deficiencies.
 - **“Vitamin C Liquescence”:** 2 teaspoons per day. A basic protective water-soluble vitamin.
 - **“Vitamin A” and “Vitamin E”:** 5,000 IU and 100 IU respectively per day. These are two basic protective fat-soluble vitamins.
 - **“Immune Stim” and/or “Oriental Cold and Flu”:** 1 bottle in the flu season as a preventative measure.
 - **“Beautex”:** 10 drops 3 times a day. Exposure to beauty shop toxins.
 - **“Algin”:** 10 drops once each day. For radiation exposure.

Appendix 3

Detoxification

Ease of flow is wellness. Ease of flow involves the physical, the spiritual and the emotional. When disease starts, we get “Dis-Ease” of flow or blockage of flow. This usually starts with the inability to detox. If you do not detoxify, you cannot nourish. Work on detox first, then absorption, nutrients, mental attitudes, spiritual, social and finally education.

hepatic clearance + renal clearance

$$\text{Clearance (elimination)} = \frac{\text{hepatic clearance} + \text{renal clearance}}{\text{volume of water specific to the toxin}}$$

Kidney and liver function, and the amount of good water consumed, determine the clearance. The volume of water needed to facilitate removal of toxins varies with the toxin: monosodium glutamate, for example, requires much less water for its elimination than a lipid-soluble toxin such as, say, DDT.

We do know the clearance factor of a toxin is a mathematic relationship of hepatic clearances (liver added to the kidney clearance). This equation is over the water coefficient for each toxin. Each toxin has an amount of water that it takes to get rid of that particular toxin. For example: Valium is a pharmaceutical which has an H2O coefficient of two gallons. With approximately two gallons of water, you can rid your body of the normal dose of valium, provided your liver and your kidneys are working properly. The more water, the better your clearance. For some strange reason, we find that the liver has to have a better capacity to detox than the kidney, or detoxification does not work properly. The liver should be worked on before the kidney.

The clearance factor for DDT is only 50,000 gallons of water for what you have in your body right now. The big problem is you cannot stop your exposure to DDT. Everyone has five to seven percent of DDT in their bodies now, and that amount can only increase if we do not stop the use of insecticides and pesticides. DDT is only one of the many insecticides to enter our bodies. There is no way we can detoxify fast enough, to overcome the exposure. To detoxify you need good water, a good liver and good kidneys. These are the major keys to detoxification. The better the water, the better the detox. The better the liver, the better the detox. The better the kidneys, the better the detox.

It is our opinion that we can decrease the clearance factor of water needed to detoxify by using homeopathy.

Appendix 4

Xenobiotics

“Xenobiotic” is a word used in classic biology and the World Health Organization to indicate toxic compounds. Not all toxic compounds come from the environment such as air and water pollution. Toxic compounds can be manufactured within the body. It is wrong to think that all toxins are derived from synthetic substances and external impacts. In fact, any nutrient can become a toxic problem if ingested in large amounts. Even water can be toxic, if we drink too much at one time.

Within the last hundred years, man, through synthetic development, has drastically increased our toxic exposure, which now jeopardizes life itself. These toxins that have been generated from insecticides, herbicides, petroleum, etc. have had profound impact on biology. With this in mind, a new system of medicine for detoxification must be addressed.

This new system is also an old system, for it is homeopathy. Through ingestion of very, very small trace amounts of poisons, the body can have a paradoxical rebound effect.

Present-day scientists have found in a new study of hormesis that tickle doses, small trace doses

of a toxin, such as radiation, petroleum, synthetics and chemicals can have stimulatory effects on the human body.

At the University of Wyoming cell biologist, Joan Smith-Sonneborn, has found that tickle dosages of radiation have extended the life spans of flies, rabbits and other organisms, and Health Physics devoted its entire issue to the study of hormesis. As we can see, this allows for the understanding of what homeopaths have known for years; that a small amount of a toxic agent can have a beneficial result on the human organism.

Xenobiotics allow for the understanding of hormesis that modern science is starting to understand, opening the door for a new biology and a new modality of medicine, so that we don't try to demand action with large-dose pharmaceuticals, but tickle the life-force of the patient to respond and to normalize itself for health.

Detoxification of Xenobiotics

The detoxification of xenobiotics is important and should be a central issue in health care. Even slight toxemia can block the electron transport chain, upsetting enzyme function, disturb mitogenic radiation and overtax the eliminative functions. Meanwhile, the earth is being overrun with toxins i.e., air and water pollutants, insecticides and defoliants, radioactive wastes, etc., which threaten not only the individual's powers of detoxification but life itself. Health professionals are behooved to deal with this plague of xenobiotics on both the clinical level and the community or social levels.

Exposure to toxins starts at conception. Subtle toxins can penetrate the amniotic barriers and interfere with development. The figure at the bottom of the next page illustrates the prenatal periods during which organs are susceptible to serious damage from exposure to toxins. The ear is most sensitive, which probably accounts for the otitis and hearing disorders prevalent in our society.

Everyone has a toxic burden, consisting of their total accumulation of xenobiotics. When the toxic burden reaches a level that exceeds the power of the detoxicative mechanisms' ability to cope, a breakdown occurs. The breakdown usually occurs as a "last-straw" sort of situation: the toxic burden built up over decades is suddenly manifest by a superficially trivial exposure or event.

Dr. Reckeweg's Homotoxicology describes five levels of defense against toxins:

1. The reticuloendothelial system. This consists of the lymph system, white blood cells, macrophages and the humoral wing of the immunity (antibody development).
2. The pituitary/adrenal axis. This system is activated when the other systems are overloaded.
3. The neural reflex system. This includes the entire nervous system.
4. The liver. The liver performs an array of detoxicative functions with its oxidases and via the bile.
5. The mesenchymal system (connective tissue).

We might broaden Dr. Reckeweg's system #1 to include the skin and lungs, making system one representative of the instantaneous defense system. Kidney and other endocrine functions can be added to system 2. A new category, system 6, can be added to complete the list: the bowel, especially the bowel's flora. The bowel's flora shifts in response to the toxins it encounters. So-called "unfriendly" flora such as candida may actually be friends in disguise, since they help deal

with toxins that might otherwise overwhelm the system. Yeasts, for example, are better equipped than bacteria to deal with heavy metals.

Identification and treatment of allergies or hypersensitivities, stress reduction, awareness training, physical culture such as exercise, yoga, etc., proper food and water, nutritional supplementation and others can reduce the toxic burden and avert health catastrophes.

Also, cleaning the environment is helpful and, in some cases, mandatory. Toxins obey the second law of thermodynamics and tend to diffuse from areas of high concentration to areas of low concentration. Thus, if an individual can be removed from a toxin-laden environment, the toxins will eventually pass out of the system. This is always for complete healing and sometimes for noticeable results: if the individual has a severe hypersensitivity to a particular environmental contaminant, he must be removed from contact with it.

Detoxification can be speeded by good homeopathic prescribing and by nutritional supplementation. The latter are limited in their usefulness, but are good for fortifying the system and can act as chelating agents.

Detoxification programs should last from three days to a month, depending on the individual case. After that you will need to rebuild tissues through improved diet, exercise, stress reduction and mental treatments. These phases of detoxification and rebuilding should be cycled for complete healing.

We detox through the urine, the kidneys, the blood, the bowel, the liver, the small and large intestine, the breath, the lungs, the sweat glands and the skin. Mucous and sinuses are internal. They are meant as an internal drainage that should help tip us off if something is wrong. We must not forget the need to detox our mind, our spirit, our social and our environment.

There are five principal avenues of elimination. The function of each of them should be encouraged, along with the use of homeopathics.

1. **Lungs.** Naturally, most gaseous toxins exit the body via the lungs. Deep-breathing exercises and ion generators are valuable for disfunction.
2. **Bowels.** Most solid wastes exit the body via the bowels. Bowel function can be promoted with bulk laxatives (Mucovata, bran, etc.), peristaltic stimulants (herbal laxatives such as senna, cascara, etc., and the acetylcholine precursors choline and pantothenic acid), stool softeners, acidophilus, and enemas or colonics when necessary. Long-term use promotes dependency, robs potassium and depletes muscle tension.
3. **Skin.** While the skin is one of the most neglected avenues, encouragement of elimination by this route can be very advantageous. Exercise, saunas, sweat baths, swimming or any activity that breaks a sweat and opens the pores is beneficial.
4. **Kidneys.** The filtering of waste through the kidneys is vital. The primary requisite here is plenty of good water - energetically active, pure and well-oxygenated.
5. **Mucous membranes.** These dump toxins into the intestines for elimination and control parenchymal endothelial balancing of minerals.

Urine

Bowel

In stool analysis there are many different types of stools, and the quality of the stool can tell us much about the health of a person.

Steatorrhea can be found in a person by looking at the person's stool. In steatorrhea there is an inability to absorb fats, and an inability of the small intestine to make the proper enzymes to break down the fats, proteins, and carbohydrates. This will result in a stool which has some of the following characteristics:

1. The stool will be light in color.
2. It will float because of the high fat content.
3. It will be oily.
4. It will have a fowl smell because of the foods not able to be broken down, sometimes even containing undigested particles of food.

This might trigger us to use small intestine digestive aids to help in the digestion of the fats.

A silver or aluminum-colored feces, especially accompanied by jaundice, could come from a growth blocking the pancreas gland duct and warrants medical attention. This is an extreme case of steatorrhea.

An internal ulcer, which bleeds into the intestinal tract, will cause a black, crusty type of stool. This is due the heavy dose of hemoglobin that has formed in the stool. These individuals should take an ulcer formula such as "Ulcer" and be on a cabbage juice diets to help increase the vitamin K factor in the blood and heal the ulceration.

Black or tarry-colored stools, not related to large doses of iron, are suspicious evidence of bleeding in the gastro-intestinal tract. Sometimes taking large amounts of aspirin can cause gastrointestinal upset, and possibly even breaks or bleeding in the gastrointestinal tract.

Pencil-thin stools can sometimes be indicative of an allergic substance that has been eaten by the person, which causes a histamine-type release swelling of the tissues in the large intestine, and this swelling results in very thin stools. These thin stools, thus, can be indicative of an allergic reactivity to a substance that the person might have consumed.

To test for lactose intolerance, we should look for gastrointestinal symptoms that will disappear if the person avoids all milk products for four days. Then if the person drinks milk, and the symptoms recur, it will tell us that there is a possibility of lactose intolerance. Then by taking commercial lactate, or any other commercial products that are preparations of lactase with milk, we can see if that will help the situation so that we can further diagnose the lactose intolerance.

Greenish-type stools may be indicative of a problem with the bowel in the liver release.

An extremely fowl odor might be an indication of a parasitic infection, such as giardia, or possibly amoebae.

If the feces size seems to change, and has different consistencies, this could be a sign of an obstructed bowel.

Stool analysis can also reveal intestinal parasites, as we can look for worm eggs with a microscope using sugar solutions. (Occult) blood analysis can tell us about the possibility of colon-rectal cancer, red color in the feces can reveal visible blood, not just occult blood.

Tapeworms can come from eating raw, or inadequately-cooked meat, such as steak tartare, raw fish, and other sushi reparations. Most worm infestation comes from being barefoot on the ground or pavement where dogs have deposited excrement containing worms. Even where there are no breaks in the skin, these worms can get into the feet. Hookworms can complicate intestinal function and also cause anemia.

One test for tapeworms in a child can be accomplished by the "scotch tape" test on a glass slide. Every night for a week, take a piece of scotch tape, wait for about one and a half to two hours after the child has been under the warm blankets. Often times the worms will come out to lay their eggs at the anal area of the child. Wind the piece of scotch tape around the eraser end of a pencil, sticky-side out. Touch the sticky surface to the anal are of the child. Peel the scotch tape and put it onto a glass slide; look through a pocket microscope. You will see the pinworm eggs if they are there. A 30-power pocket microscope bought from Radio Shack can help to tell us about these different worm intruders. Pinworms are the number-one cause of appendicitis. Most of these eggs can be seen with the naked eye, but the microscope definitely helps. This child will also have itchy buttocks, and often times his nose will be itchy as well.

Giardia is so small that it cannot be seen with the naked eye, but it can sometimes be seen with the help of a 30-power pocket microscope.

The amount of the stool should be related to the amount of the diet. It is normal to have at least one bowel movement a day, sometimes two or three. To have one per meal is not irregular. If one has eaten large quantities of food and not had enough bowel movements, this might indicate a problem. Large quantities of grains, fruits, vegetables and other fibrous foods can often increase the amount of feces, while large amounts of proteins and liquids tend to decrease it. The color of the stool should be medium brown, and should be uniform in color throughout. Eating large amounts of green vegetables sometimes makes the stool green. Certain anti-biotics can cause a yellowish tinge. Food colorings, dyes, and drugs can also alter stool color. The consistency should be firm, not hard, or watery. Each segment should be from one half inch to one inch in diameter.

A diet high in fiber or not enough digestion will cause the feces to float. The normal pH of the stool should be close to 7, neutral. Large amounts of meat in the diet can make it more alkaline; large amounts of carbohydrates will make it more acid. There should be little evidence of glucose, no evidence of blood, white blood cells or parasites. Eating rare meat, certain vegetables and fruits, and vigorous brushing of the teeth are things that could cause a false, positive blood test of the stool.

Breath

Breath as a system of detoxification is the number-one system of fat removal in the body. We must depend on the pulmonary expertise of the heart and lung system for it to be able to detox.

There are several different ways in which we can measure the pulmonary ability of the system. An easy test to use for measuring the pulmonary function is that of walking one-half mile in six minutes. If, for example, a person finds himself out of breath after walking a few minutes, or after walking the one-half mile, it is reasonable to assume that there is a pulmonary function problem that needs medical attention. A person should also be able to hold his breath a minimum of 40 seconds to be healthy; anything under 30 seconds indicates the need for medical attention. A good set of lungs should be able to blow out a candle at two and one-half feet. Anything less than

two feet shows a problem with the pulmonary system.

Accompanying the breath is sputum, which can be analyzed as well. It can be analyzed for several different factors very easily. If there is a pink-tinged sputum, there might be some blood from the lung, possibly from an asthmatic who has a little bleeding in the lung. A rusty-colored sputum is sometimes an indication of pneumonia. Yellow sputum is a sign of bacterial infection, whereas green sputum might indicate sinus involvement, as well.

We can perform the match test by holding the mouth open as much as possible without puckering the lips, taking as deep a breath as possible and exhaling the air. A match held six inches from the open mouth should be easily blown out. Inability to successfully perform this test means that there is the possibility of a lung problem.

Another test is that of the forced expiration time test. With the mouth open as wide as possible, breathe in as deeply as you can and as forcibly and as fast as you can, exhale. You should be able to exhale out all the air within two to six seconds. If you take more than six seconds to push out all the air from your lungs, it is a warning signal that there might be an obstructive or restrictive problem within the lung.

Another factor that can be brought into analysis is that of breath odor. Halitosis, or bad breath can be significant of certain medical problems. Often times the valve at the top of the stomach, the cardia valve, is rotted away or has an inability to close. This will produce a putrid odor. Infections of the sinuses and teeth will produce halitosis without the complication of the hydrochloric acid smell. Sweet odors can tell us about improper spleen function. An acetone type smell can be a warning sign for diabetes. It might also appear, if someone is on a reducing diet or has too few carbohydrates. This can produce ketosis. If combined with yawning, this means that the person has slipped into a ketonic acidosis, which could be risky. Advise this person to eat some carbohydrates, such as fresh fruit. See if it brings energy to the system.

An ammonia breath odor can be the first sign of a kidney or possible liver disease.

A frothy type sputum can be a clue that there is heart failure or possibly lung edema, showing that the heart is performing inadequately.

If there are little pieces of chalk-like substance in the sputum that are actually calcium, this could be an indication of a fungus infection of the lung, or the consequence of exposure to certain minerals or silicosis.

Carbon monoxide can accumulate in the system and block oxygenation. It will drastically limit estrogen production and also limit testosterone production in males. Many forms of impotence are complicated by a decrease in oxygenation by a carbon monoxide blocking. This happens particularly in smokers. Decrease in sexual drive in either men or women can be a sign that there is carboxyhemoglobin, which means that carbon monoxide has taken the place of oxygen in the blood.

Carbon monoxide testers can be bought from the American Gas and Chemical Company, North Vale, New Jersey, 07647. For \$35 a package of twelve tests can be ordered, which will change color in the presence of carbon monoxide. Thus, smokers and other people who might be at risk of carbon monoxide poisoning might want to buy this valuable kit.

Sweat

A lot of people do not sweat enough and some people sweat too much. For the most part, women do not naturally sweat as much as men. But women should sweat. Everyone should sweat. If a person is doing strenuous exercise and not sweating, it is probably the lungs that need to detoxify.

Often times excess saltiness in the sweat, especially in children, can be indicative of cystic fibrosis, which is a disturbance of the pancreas and its ability to generate different types of enzymes. Thus, a person cannot properly digest different compounds and this results in excess saltiness in the skin. We can taste the skin of our children, and if we can detect cystic fibrosis early enough, we can sometimes save these children, through different types of dietary procedures.

Sticky sweat can show a problem in the utilization of water, which might be significant at early-stage kidney or bladder dysfunctions.

Excess odor of the sweat, as in underarm odor, can also be a dysfunction of dietary involvement, showing that there is too much red meat or too many toxins in the diet. Also this odor can be complicated by different bodily infections. Some of these are stubborn and resist the soap of the washer and dryer. Sometimes these clothes need to be even microwaved at high temperatures in order to kill the different fungi and bacteria that the washer and dryer might miss.

Use of anti-perspirants which involve aluminum can contribute to Alzheimer's and other systemic problems. Use of other deodorants which block the release of sweat can sometimes cause problems with blood pressure and other detoxifying systems. To fight excess body odor we should clean up our diet, reduce our stress, and lead more natural lives.

Detoxification through the Endocrine System

Toxic Endocrine

Endocrine Gland	If Toxic, System Used to Detox
Adrenal	Lungs
Thyroid	Skin
Pineal	Eyes
Pituitary	Sinuses
Hypothalamus	Psyche
Gonads	Genitalia, Urine
Kidney	Urine
Stomach	Stool
Liver	Stool
Thymus	Sweat

Sweat glands are the back up of the thyroid. A sweat problem usually involves the thymus and the thyroid. If there is a sinus problem, the pituitary is usually involved. A problem in the lung is an indication that there is a problem in the adrenal gland. A bowel problem indicates a problem in

the large and small intestine or a weak liver. If there is a urine problem, the kidneys may be weak. Drainage of the eyes indicates the pineal gland is weak.

Homeopathic glandulars of the endocrine system are recommended to help in the detoxification of the glands.

General and ancillary support during a detoxification program includes balancing of the autonomic nervous system, provision of ergodizing agents, treatment of allergy/ hypersensitivity and mental treatment (stress reduction, etc.). Keep in mind that the body's effort to detoxify itself can be stymied by inappropriate mental or emotion habits: repressed feelings will express eventually as an increased toxic burden.

Following are outlines of suggested detoxification programs. As always, such programs must be modified or combined to suit an individual case.

Detox Program - Number 1

Detox program #1 is for toxicity in the reticuloendothelial system or combinations of them.

Vitamins and Minerals: Ascorbic acid, one gram (or more); Vitamin A 25,000; RNA/B-12/Folic Acid, 2 tablets/capsules; Chelated Cell Salts; Garlic; per day.

Glandulars: Homeopathic Lymph; Immune Stim; Spleen (6x, 12x, 30x, 60x, 100x combination) as directed.

Botanicals: Red clover; plantain; nettles; prickly pear; lobelia; marigold; Garlic extract.

Others: If infection is present, "Blood Liquescence", "Lymph Liquescence" is recommended.

NOTE: Cleansing the lymph and blood may temporarily stimulate candida growth. If this problem already exists, warn the patient of possible flare-up.

Detox Program - Number 2

Detox program #2 is for toxicity of degree and duration that has called into action the endocrine system.

Vitamins and Minerals: Vitamins A; C and E daily (roughly 25,000 IU, 2-3 grams and 100-200 IU, respectively). Chelated Cell Salts. Others: iodine; chromium; selenium; manganese and molybdenum.

Glandulars: Homeopathic Lymph; Spleen; Mammary; Parathyroid; Pancreas; Adrenal Prostate; Pituitary; Thymus; Thyroid (at 6x, 12x, 30x, 60x, 100x combination) as directed.

Botanicals: Scullcap; echinacea; mullein; kelp; black radish; alfalfa.

Others: "Phosphatidyl Choline" and "Essential Lipoids Garlic Oil " if infection is present.

NOTE: Always treat the digestive system. Support with HCl, enzymes, etc. to reduce the workload of the pancreas. Encourage consumption of legumes. Balance the pH, autonomic nervous system and hormones.

Detox Program - Number 3

Detox program #3 is for toxicity of degree and duration that has called into action the nervous system.

Vitamins and Minerals: B or G complex. Chelated Cell Salts.

Glandulars: Homeopathic Major Nerves; Pituitary; Metab; Brain (at 6x, 12x, 30x, 60x, 100x) as directed.

Botanicals: Scullcap, plantain, lily of the valley, black radish, alfalfa.

Others: "Phosphatidyl Choline, Lecithin ", "Vitamin C Liquescence", "Fatty Acid Liquescence".

NOTE: Chiropractic care and TMJ management are vital here. Balance the autonomic nervous system and reduce stress as much as possible. Encourage 24 hour fasts, one day per week.

Detox Program Number - 4

Detox program #4 may be the most important. In extreme toxicities, it is the starting point. It deals with the liver, whose detoxicative abilities are vast. The liver conjugates xenobiotics with various organic compounds to facilitate elimination.

Vitamins and Minerals: Ascorbic Acid, one gram 3-8 times per day; Vitamins A and E, daily (roughly 25,000 IU and 100-200 IU, respectively). Choline and Inositol as a lipotrope. Selenium; Manganese; Zinc; Copper; Molybdenum; Iron; Chelated Cell Salts.

Glandulars: Homeopathic Liver/Gallbladder; Stomach/Pancreas (at 6x, 12x, 30x, 60x, 100x combination) as directed.

Botanicals: Walnut; Blue Vervain; Scullcap; Wild Yam.

Other: "Fatty Acid Liquescence"; Intestinal Cleanse; "Phosphatidyl Choline"; "Liver Liquescence"; "H.E.P.A."; "Vermex".

NOTE: A liver flush is always indicated. As always, homeopathics of toxic agents should be identified and prescribed.

Detox Program Number - 5

Detox program #5 is for detoxification of the connective tissue. there are circadian shifts from acid to alkaline that occur in humans, one purpose of which is to contract and expand the connective tissue to expel toxins. Subtle inflammation of these tissues is thus natural and normal. Dilution is one of the first stages of resistance to toxins. Inflammation should be viewed as a process of dilution, local tissue edema. If the toxins are not adequately disposed of the inflammation becomes less subtle, eventually becoming perceivable.

Vitamins and Minerals: Vitamins A; C and E, daily (roughly 25,000 IU, 2-3 grams and 100-200 IU respectively). Chelated Cell Salts; Manganese.

Glandulars: Homeopathic Muscle/Ligament/Cartilage; Adrenal; Bone (at 6x, 12x, 30x, 60x, 100x combination) as directed.

Other: Essential Fatty Acids, Pantothenic Acid; Lymph Liquescence; Anti-Inflammation.

NOTE: Large doses of antioxidants are helpful for achieving rapid control of inflammation; antioxidants are also needed for long-term connective tissue healing. Avoid most polyunsaturates, since most of these fatty acids are precursors of the pro-inflammatory prostaglandins. Aspirin and other non-steroidal anti-inflammatory drugs act by blocking prostaglandin production. It is important also to curtail animal protein intake, treat allergies and reduce stress.

Detox Program - Number 6

Detox program #6 is for detoxification of the bowel and, following that, reinoculation of the bowel with beneficial bacteria.

Vitamins and Minerals: B-12; Pantothenic Acid. Pantothenic acid and choline precursor acetylcholine, a helpful neurotransmitter if the bowel is atonic.

Glandulars: Homeopathic Small and Large Intestine; Thymus (6x, 12x, 30x, 60x, 100x combination) as directed.

Botanicals: Marshmallow root

Other: Intestinal Cleanse; "Disodium Phosphate"; Chlorophyll; "H.E.P.A."; "Liver Liquesence"; "Immune Stim"; "Digestive Liquesence".

NOTE: Always check first for worms, fungi (candida especially) or other intruders. If candida is present, treat with FNG and support with Vitamin A, and iron.

Detoxification is very important. In order to detox properly, the liver, kidneys and small and large intestine must be in good condition. The liver should be the first concern, then the kidneys, then the small intestine.

Liver Detoxification

Liver and Gallbladder Flush: Drink two or three glasses of apple juice or apple cider a day, for two or three weeks before the liver flush. If allergic or intolerant to apple juice, switch to a lime or grapefruit juice. Drink one glass of grapefruit juice in the morning for the same three weeks. Grapefruit juice detoxes the gall bladder and lowers cholesterol. Patients often mistake the detox reaction of grapefruit juice for some acid intolerance, while actually it is removing toxins. To remove a splinter there is some pain. The same with some systemic toxins, so patients must be encouraged to tolerate some detox reaction. Stones only form in the body when magnesium is in excess or deficiency. If the patient has not been consuming large quantities of magnesium then suspect magnesium deficiency syndrome, it is quite common. Supplement 25 to 100 mg per day. Too much more magnesium can cause hypoadrenia over a long time.

- A. Eat a meal early enough in the evening to allow time for following the steps.
- B. Three (3) hours later take one (1) teaspoon of Disodium Phos. in 2 oz. of water.
- C. One (1) hour later, repeat B.
- D. One (1) hour later, take 1/2 cup of lemon juice with 4 tablespoons of olive oil.
- E. Go to bed. Lay on your right side for 1/2 hour.
- F. Next morning on an empty stomach repeat B.
- G. If the next morning, there is no bowel movement, do an enema.

Liver Program: "Liver Liquesence" - 3 teaspoons per day; "H.E.P.A." - 3 pills at bed time. Do this for 3 weeks. "Digestive Glandular General" - 1 with meals for one week. "Liver/Gallbladder" - 10

drops, 3 times a day, 1 bottle. "Oriental Herb (Liver)" - 5 drops for 3 days.

Gallbladder Detoxification

"Liver/Gallbladder" and "Bear Gallbladder" homeopathics are recommended for gallbladder conditions along with magnesium and cholesterol management. Take - 10 drops, 3 times a day.

Kidney Detoxification

The "Kidney Liquesence" is recommended to clean up the kidney. Take 2 teaspoons per day.

Kidney Stone Flush: Do this until the stones are dissolved, but not for more than 6 weeks.

"Kidney, Adrenal, Ovarian or Prostrate" - 10 drops, 3 times a day.

"Oriental Herb (Kidney)" - 10 drops, 3 times a day, for 1 week.

"Kidney Stone" homeopathic - 10 drops, 3 times a day.

- 100 milligrams of B6
- 100 milligrams of Magnesium
- into 10 oz. glass of
- 1/3 apple juice
- 1/3 lemon juice
- 1/3 juniper tea - 2 glasses a day.

Lymph Detoxification

Lymph should be worked on next. When there is build up in the lymph, this can be a sign of bad quality protein. When lymph starts to build up bad protein, it goes into the blood. Everyone should have some neurolymphatic work done on them. This will help to help stimulate the cleaning of the lymph. "Lymph Liquesence" is recommended for clogged lymphs. "Blood Liquesence" not only satisfies the anemia person, but helps with bad skin due to bad lymph and blood. It also contains lymphatic cleansers.

Lymph Program: "Lymph Liquesence" - 8 teaspoons (day 1); 7 teaspoons (day 2); 6 teaspoons (day 3); 5 teaspoons (day 4); 4 teaspoons (day 5); 3 teaspoons (day 6); Level off with 2 teaspoons per day. "Digestive Enzyme Liquesence" with meals. "Digestive Glandular (Fat, Protein, Carbohydrates)" - 2 each before bed on an empty stomach. "Lymph, Spleen, Mammary" - 10 drops, 3 times a day. "Oriental Herb (Lymph)" - 10 drops, 2 times a day, for 2 weeks.

Intestinal Cleanse Program

For 10 days to 2 weeks: "Small and Large Intestine" - 10 drops, 3 times a day. "Health and Beauty Poulitice" - 1 tablespoon in 6 ounces of water or juice, in the morning and at night. Seventy percent of diet should consist of raw fruits and vegetables (avoid iceberg lettuce and popcorn). "Herbal Laxative" - 1 with meals. Thirty ounces of filtered water (with the "Homeopathic Catalyst Water" added) should be drunk each day. "Essential Lipoid Factor" - 3 capsules with evening meal. "Fiber Capsule" - 2 capsules, 30 minutes before meals.

Activated charcoal and the intestinal cleanse program are very good for a person with a problem in the large intestine. Activated charcoal is not only used in therapy, but in diagnostic testing. It informs us of transit time. Calculate when your normal bowel movement takes place. Say you

normally have a bowel movement around 9:00 a.m. Figure back 14 hours because normal transit time should be around 14 to 16 hours in the body. Counting back 14 hours, calculates to 7:00 p.m. the day before. Take the activated charcoal with a little bit of food at 7:00 p.m. and wait to see, if the next morning, the charcoal appears in the stool. If the charcoal is in the stool, it is a good indication that transit time is 14 hours away or less. Now, if the next morning the charcoal is not in the stool, then you know that the transit time is over 14 hours. The next time instead of taking the activated charcoal at 7:00 p.m., take it at 3:00 p.m. and wait to see when the charcoal appears. Do this one time during a week. If the activated charcoal does not appear in 24 hours, when does it? You will find certain people think their transit time is normal. Truth of the matter is, their transit time is 24 hours or 36 hours. They are just passing today what they ate a couple of days ago. Canned corn may be substituted for the activated charcoal to check transit time. If your transit time is too fast, your minerals will not be absorbed.

This program should not be performed for more than one week every three months. Not only does activated charcoal help to eliminate toxicity in the body, but it also measures transit time.

Appendix 5

General dental mercury removal consideration

1. The quadrant containing the highest single reading should be removed first, and further quadrants in descending order, as indicated on the chart. This sequential removal may be crucial in mercury toxic patients.
2. Where possible a rubber dam should be used, in conjunction with an efficient high volume evacuation, and high speed cutting tool with water coolant spray, to protect the patient from the aerosol.
3. When the patient is extremely hypersensitive to mercury, they may react during treatment. If there are signs of an adverse reaction, give six grams of sodium ascorbate, (Vit.C) in a glass of water. Charcoal, Bentonite, Adrenal + Liver treatment can also assist.
4. Negative current excites nerves. When fillings are removed from teeth with high negatives, the tooth may become hypersensitive, which may be avoided by inserting a temporary dressing for about two months.
5. If any other metal is used as a restorative material, all amalgams should be removed first.

When drilling out amalgam

6. Cover the patient's eyes with a damp cotton wool, or use wrap around goggles.
7. Use R.A. nosepiece with tubing attached, to extend out of operating area, or work using oxygen flow or charcoal filter.
8. Confirm that the patient has been advised on pre-treatment detoxification procedures.
9. use comfortable music The QX VRI or other comforting distraction. The QXCI can relieve pain and other tension as well.

Dental pre and post-treatment plan

HOMEOPATHIC DENTAL AMALGAM (NV)

80

Six drops twice a day, either under the tongue, or in a little water.

Separate from food by one hour either side. Start seven days before treatment and include day of treatment.. Continue same dose for three weeks, if dental treatment scheduled, take it on that day.

HOMEOPATHIC DENTAL INJURY (NV)

Six drops twice a day, either under the tongue, or in a little water. For stimulation of healing.

Separate from food by one hour either side. Start seven days before treatment and include day of treatment.. Continue same dose for three weeks, if dental treatment scheduled, take it on that day

CHARCOAL

Take three charcoal tablets half an hour before any dental treatment involving amalgam removal and three in morning and three at bed for two weeks after.

BENTONITE CLAY

Take three bentonite tablets half an hour before any dental treatment involving amalgam removal and one in the morning and three at bed for two weeks after.

GLUTATHIONE PEROXIDASE

Dose:- one with water half an hour before breakfast. Start two days before treatment involving amalgam removal. Continue for two days after treatment, that is five days in all.

ORGANIC CHELATED SELENIUM ZINC and VITAMIN E

No more than 50 mcg of organically bound selenium, 25 mg of zinc, and 400 iu of Vitamin E, a day at bed with 10 oz. of water. Use for five days after. This will prevent kidney toxicity of the selenium.

FATTY ACID LIQUESCENCE

30 drops a day for one week before and for one month after.

VITAMIN C POWDER

Start right away, Dosage :- 1/4 teaspoon (=1 gram.) Once a day. Or use 1000mg chewable.

On treatment days :- 1/4 teaspoon before and 1/4 teaspoon after treatment.

Magnesium Succinate:

- Start: - on each day of treatment
- Dose: - 2 capsules 2 hours before treatment; 2 capsules within 2 hours after treatment, then drink one pint of water over the following two hours
- Support adrenal, liver, kidney and lymph when needed.

Good Natural multivitamin & mineral:

- Start : - 8 days before treatment
- Dose: - 1 per day in the morning(with food)

81

- Continue : - for 6 weeks after treatment

CORIANDER (Cilantro)

This must be fresh and preferably organic if you can get it. (It is very easy to grow at home in a sunny position) - dried coriander does NOT work well Fresh is better.

Research published late in 1996 has shown that Coriander has a wonderful capacity to remove heavy metals and especially mercury from the body. This is a revolutionary discovery and makes Cilantro the first known substance that mobilizes mercury from the CNS. The active principle is unknown. But the sepulative idea contains the high organically bound selenium and the quantum quadrapole found in the remedy.

Resipe for Cilantro-pesto:

Buy fresh organic Cilantro. Use equal parts black olives. Wash. Put in blender with small amount of water, dash of sea salt (Celtic salt is good) and olive oil and Fatty Acid Liq NV 20 drops, Blend until creamy. Take 1 tablespoon 3 times a day with meals. Do not heat, spread on bread or crackers, use on salad. More often, if brain severely compromised; depression, Alzheimer's disease, "fogginess", etc.)

Alternate Pesto Recipe

- Coriander - 1 bunch
- Black Olives 10.
- Garlic - to taste
- Black pepper to taste
- Coconut desiccated ½ cup
- Lime ½ juiced
- Olive Oil - cold pressed
- Fatty Acid Liq, 20 drops

(Any black vegetable such as black pepper and black olives are black from excess selenium and chromium, the organic bounding will not stress the kidney but assist detox of heavy metals, Guinness beer also will help no more than two pints a day)

Blend all together and keep refrigerated for one week

PLEASE NOTE: It is important to continue with detoxification after removal of fillings in order to remove mercury which has built up over the years.

References

Crinnion WJ. Environmental toxins and their common health effects. *Altern Med Rev* 2000, 5(1):52-63.

P.L. Bigazzi, "Autoimmunity induced by metals", in Chang, L., *Toxicology of Metals*, Lewis Publishers, CRC Press Inc. 1996., p835-52.

PROFESSOR DESIRÉ DUBOUNET

and her friends have spent over 35 million dollars to bring the world a professional and thorough course on Wellness, Naturopathy and Neuro-Electro-Physiology of Biofeedback as Bioresonance.

She is such a humanitarian Angel, she lets you pay for the course videos, books and materials with Karma...



FOR MORE INFORMATION GO TO
WWW.IMUNE.NAME



These are the **TOP FIVE REASONS** to get a Doctorate in Wellness PHD International Medical University degree at home.

1. Getting a degree means you will increase your earning potential. Studies have shown that at home study is just as good as attended classes.
2. Study and Complete Courses at Your Own Pace. Use this to maximize the learning.
3. Scheduling Convenience. Work when you are ready to work.
4. Teaching Faculty Who Actually Have Work Experience in Your Field of Study. Global faculty at IMUNE is with worldwide famous doctors.
5. Save Money on Travel, Parking, Childcare, and Books. You save money the world saves energy, this makes you and the world better.
6. Employer Support. Many employers offer tuition reimbursement for employees' tuition associated with training in their fields. Employers also tend to encourage enrollment in online degree programs because they know employees will be able to go to school and still be able to be committed to their jobs. Don't be afraid to ask your employer. Every company needs a wellness consultant.

Professor Desiré Dubounet the world's most famous Naturopath and her friends have spent over 35 million dollars to bring the world a professional and thorough course on Wellness, Naturopathy and Neuro-Electro-Physiology of Biofeedback as Bioresonance. She is such a humanitarian Angel, she lets you **pay for the course videos**, books and materials **with Karma** go to www.imune.name for more information.

Title

The Long-term Pathological Findings of the Camelford Toxicity group.

Subtitle

The Premature Ageing Effects of a Toxic Water Syndrome Case.

By

Dr. William Nelson LPCC , Peter Smith LCH

ABSTRACT:

In July 1988, a toxic water spill in the Camelford water district by South West Water, the public water utility, in Cornwall England resulted in some 20,000 people being exposed to a toxic cocktail of chemicals in their drinking water. This produced a host of different physiological diseases. It also resulted in a homoeopathic practitioner, together with other colleagues, launching into long-term 7 year study of the effects of this toxicity on the population.

Besides extensive case notes on 200 people, hair and nail samples, several different electrical measures, chemical measures, and psychological interventions have yielded a understanding of these patients' disease profile. Various lengthy papers have been prepared by the North Cornwall Homoeopathic Project and the Lowermoor Support Group. A book is in preparation.

One of the key factors that have been observed in this population is that of premature aging. This is discussed within this article.

INTRODUCTION:

As we age many factors happen to us. In the Merke manual ageing is found to basically have an effect on the:

1. thermal energy of the body,
2. the cerebral spinal fluid,
3. memory,
4. flexibility,
5. loss of lean body mass,
6. fall in basal metabolic rate,
7. a fall in hormonal production,
8. a fall in sexual function

Besides a detrimental effect on memory, flexibility and balance aging also affects nutritional intake. Many different types of diseases are outlined in the field of gerontology. In our test population, in Cornwall, England exposed to the toxic water, we have seen that there is indeed a possibility that premature aging is occurring. Whilst attempting to develop our scientific criteria it became apparent that there is very little literature in the scientific field regarding premature aging, and certainly very little that actually allows us to measure aging with direct means.

In other words aging is a phenomena that is normally observed and measured over decades as opposed to a single-figure timespan and is largely a matter of recording the slowly developing aging factors in a patient. There seems to be very little criteria to measure whether a person is aging at an excessive rate.

Yet this seems to partially explain the phenomena observed in the Camelford project.

METHOD:

In developing our electrical measures we have used the Quantum Med 4000 to measure oxygenation, thermal capacities of the body, thermal reactivity, hydration, electrical reactivity of brain wave, galvanic skin resistance, Capacitance and Inductance changes.

The Quantum med 4000 allows for the overall measurement of electrophysiological reactivity. This then is used to chart the reaction to thousands of chemicals, hormones, nutrients, allersodes, sarcodes, and nosodes. This article does not discuss the reactivity measures in specifics. To learn more about this we point the reader to the references on Reactivity.

In developing our analysis we have been able to come up with some propositions concerning the phenomenon of aging, which have to do with the patients' thermal reactivity, oxygenation, hydration, capacitance and inductance. A phenomenon of aging is that there is a lowering of the production of hormones and an effect on nutrition.

With regard to hormonal production, we observe patients who demonstrate an enhanced reactivity when exposed electrically to pituitary, hypothalamus, adrenal and pancreas samples. Nutritionally, we observe increased reactions to iron, protein, calcium, and the absorption of other types of nutrients. (Reactivity normally points to either a shortage of or an overabundance of the substance(s) and points the practitioner to further examine the status of the patient.)

There is no doubt that memory, flexibility and balance are associated with aging. Many of our patients demonstrated these symptoms to a degree that was clearly statistically significant.

Generally, the patients presenting in this concern demonstrated a loss of lean body mass, a fall in their basal metabolic rate, a loss of general memory, and ability to focus their mental energy, a general and progressive loss in flexibility, loss in balance, visual acuity, hormonal function, and a marked loss of sexual appetite.

This symptom picture was charted by the project in a raw epidemiological study incorporating data from 40 females and 30 males across the age range. The patients reported not only an almost

instant, overnight 'aging' but also a steady, progressive decline in their wellbeing. This decline is accelerative compared to the 'normal' population observed in homoeopathic practice in nearby towns.

These reports and observations of relatively rapidly-progressive aging, when coupled with our electrical reactivity scores, point strongly to the hypothesis that there is indeed a premature aging phenomenon occurring with the Camelford project population

Our original homoeopathic and nutritional intervention included homoeopathic hormetic formulas for the removal of heavy metals, bad water, and aluminium - the pollutant substance was 20 liquid tonnes of highly acidic aluminium sulphate, a flocculant used purely cosmetically by the water company to settle harmless detritus. Also, nutritional factors of choline, calcium, iron, and other supplements were used with the patients to boost intestinal absorption of these substances. Clinical observations of the small initial group of patients tested showed clearly that those that complied with the prescribed routine seemed to experience a temporary reversal in the premature aging process. However, in the early days many of the patients did not receive any type of homoeopathic or nutritional therapy whatsoever, and with them the acceleration of aging continued.

Clinical and electrical analysis showed an acceleration of the aging process in these patients at a rate of about 4 to 5 years for every 1. From the perspective of a licensed Clinical Counsellor it was possible to observe hormonal, memory, mood and cognition disturbances that contributed to the hypothesis that there is indeed an acceleration in the rate of aging. The efficacy of - and, in these circumstances, the urgent need for - early homoeopathic intervention was clearly demonstrated

Besides the ongoing homoeopathic treatment that was carried out from late 1988, it was decided to organise a small Pilot Study of 14 patients in October 1993. Following the successful intervention of the hormetic and nutritional remedies administered to these patients - and importantly the establishment of clear sensitisation to tapwater, the major maintaining cause of disease in the population - it was decided to follow up with an expanded study involving 56 people in March 1994.

Many of those patients taking part reported an amelioration of symptoms and a slowing or reversal in their decline. Some benefits remain to this day, others have once more resumed their decline. Considering that the intervention was a relatively short one it is fair to assume that major benefits could be extrapolated from a longer programme of treatment.

Having said that, it is only realistic to assume that after 6 to 7 years some of the patients would be incapable of correcting or reversing the slide into premature aging, or that, having aged 20 years over the last 4 to 5 years, these patients would experience extreme difficulty recovering normal lives. After a certain amount of time (different for each) it is probably impossible to reverse the aging effects of the body, as too much damage has already been done.

To reiterate, this points us to the conclusion that early intervention in these chemical catastrophes

is imperative. Failure to carry out early assessment and treatments will result in long-term accelerated aging as demonstrated by the Camelford population.

RESULTS

As we can see from the next index of our studies. That the Camelford patients have reactivity and electrical scores that are very much similar to the elderly control patients. So as we understand more of the electrical nutritional factors associated with ageing we can see that the Camelford patients display some premature ageing disturbances. Our statistical analysis shows a significant difference in the normal vs. Camelford Group and a similarity between the Camelford group and the elderly normal group.

In our next figure. We can see the comparative ageing factors of the populations taken from the Quantum Med Readings.

<u>Normal patients age 20-45</u>	<u>Camelford Patients age 20-45</u>
Oxidation Index 1-1.5	Oxidation Index 0.2-.5
Hydration Index 4-5	Hydration Index 0.75-1
Hypothermia 92-93	Hypothermia 89-90
Thermal Reactivity 1-2 degr	Thermal Reactivity 0.2-.3 degr
Electrical Reactivity 100-150e.v.	Electrical Reactivity 50-60e.v.

<u>Normal patients age 20-45</u>	<u>Camelford Patients age 20-45</u>
Oxidation Index 0.75-1.25	Oxidation Index 0.02-.5
Hydration Index 2-3	Hydration Index 0.75-1
Hypothermia 91-92	Hypothermia 89-90
Thermal Reactivity 1-2 degr	Thermal Reactivity 0.2-.3 degr
Electrical Reactivity 100-150e.v.	Electrical Reactivity 50-60e.v.

<u>Normal elderly patients age 85-95</u>
Oxidation Index 0.2-.5
Hydration Index 0.75-1
Hypothermia 89-90
Thermal Reactivity .2-.3 degr
Electrical Reactivity 50-60e.v.

Our Camelford Population then when reviewed for aging shows:

AGEING SYMPTOM	MEASUREMENT	OBSERVATION
1. thermal energy of the body,	QUANTUM MED	Accelerated
2. the cerebral spinal fluid,	UNMEASURED	
3. memory,	PSYCH EXAM	Accelerated
4. flexibility,	REPORTED	Accelerated
5. loss of lean body mass,	REPORTED	Accelerated
6. fall in basal metabolic rate,	QUANTUM MED	Accelerated
7. a fall in hormonal production,	QUANTUM MED	Accelerated
8. a fall in sexual function	REPORTED	Accelerated
9. Oxidation	QUANTUM MED	Accelerated
10. Hydration	QUANTUM MED	Accelerated
11. Electrical Reactivity	QUANTUM MED	Accelerated

DISCUSSION:

Our analysis of electrical, chemical and observational qualities in the Camelford patients, leads us to conclude that there is indeed the possibility of a premature ageing syndrome. An Acceleration that is individual to each person exposed.

This could be the effect of the toxic exposure of the aluminum and the other chemicals freed by the aluminum sulphate in the water lines. The patients then could be at an accelerated component of ageing 5 years for every 1. From our studies with the homeopathic intervention. We can conclude that there is a possibility that the homeopathic intervention of the hormetic factors of the aluminum and heavy metal disturbances can have a reversing effect on the ageing complex. And thus, in the early intervention states have the effect of reversing the accelerated ageing and thereby stopping the long-term damage. The patients who receive the early intervention seem to have the best resistance to the accelerated ageing complex. The longer patients waited for the homeopathic intervention the less the hormetic effect of the homeopathics was achieved. Thus, we can see that we need to set up some more early interventions systems for this type of ecological disaster in the future so it might be reversible in its early state

It is surmised that after 4 to 5 years some of the patients would be unable to correct the premature ageing complex. Or that having aged 20 years over the last 4 to 5 years, these patients would have extreme difficulty recovering normal lives. After a certain amount of time(different for each) we would not be able to reverse the ageing effects of the body. The damage was already done. Thus, this keys us to see that early intervention into these areas is highly wise. Early measurement and treatments much needed to stop the effects of a long-term accelerated ageing profile.

— BIBLIOGRAPHY —

1. **An Advanced Treatise in Quantum Biology.** The Staff of Maitreya, Ltd. *Acad. Press*, 1989.
2. **Towards a Bio-Quantum Matrix.** The Staff of Maitreya, Ltd. *Acad. Press*, 1992.
3. **Quantum Biophysics.** The Staff of Maitreya, Ltd. *Acad. Press*, 1993.
4. **Quantum Vibrational Medicine.** The Staff of Maitreya, Ltd. *Acad. Press*, 1993.
5. **Quantum Quality Control.** The Staff of Maitreya, Ltd. *Acad. Press*, 1993.
6. **Experimental Evidence for Homeopathy.** The Staff of Maitreya, Ltd. *Acad. Press*, 1992.
7. **Experimental Evidence for Homeopathy II.** The Staff of Maitreya, Ltd. *Acad. Press*, 1992.
8. **Homeopathy for Acupuncturists, Chiropractors and Naturopaths.** The Staff of Maitreya, Ltd. *Acad. Press*, 1993.
9. **Homeopathy for Nutritionists.** The Staff of Maitreya, Ltd. *Acad. Press*, 1993.
10. **Essential Medicine.** Edited by Ried Jones. *Churchill Livingstone*, 1993.
11. **Pharmacognosy** (9th ed.). Tyler, Brady & Robbers. *Lea Febiger*, 1988.
12. **Medical Botany.** Lewis. *Wiley*, NY, 1977.
13. **Merck Manual** (15th ed.). Edited by Berkow, M.D. *Merck, Sharp and Dome Research Laboratories*, 1987.
14. **Pathophysiology: The Biological Principle of Disease.** Smith and Thier. *Saunders*, 1981.
15. **American Medical Association Home Medical Advisor.** Edited by Clayman, Kunz and Meyer. *Random House*, 1988.
16. **Differential Diagnosis.** Harvey and Bordley. *Saunders*, NY, 1976
17. **Statistics Manual.** Research Dept. US Naval Ordnance Test Station. *Dover, N.Y.*, 1960.

Some of the Scientists that have worked personally with Bill Nelson

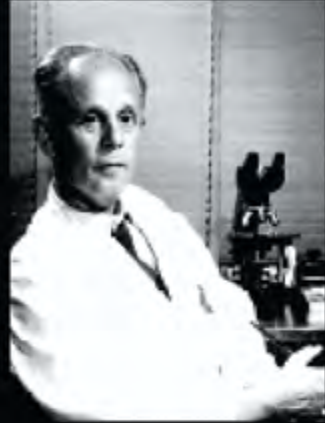

Selye János, who's legendary work on stress is the finest achievement in medicine of all time



Linus Pauling who won 2 Nobel Prizes and helped Bill with Quantic Biology and Ortomolecular



William Fowler, Nobel Lauriate, co-authored an article with Bill on the transmutation of the Elements in Biology



Albert Szent-Györgyi, Nobel Prize for discovering Vitmain C, worked with Bill to develop the Quantum Biology electron transport theory



Jacques Beneveniste



Joseph Scogna



Dr. Frank King DC



Dave Polen DC



Dr. Louis Kervran



John Stewart Bell



Richard Gerber



Julian Kenyon MD



Emanuel Revicci



Richard Feynman

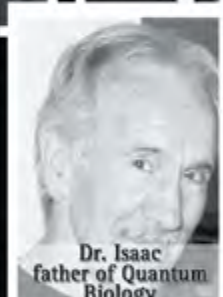

Dr. Isaac father of Quantum Biology



Brian Green



John Edward Brough Randles



Dr. Glen Rein worked with Bill at the Heart-math inst. and Estee Lauder on mathematic formulas



Attila Grand Pierre worked with Bill to validate the Promorpheus



Billy Horton



Turako Yui and Desiré Dubounet



Masaru Emoto



Edgar Mitchell



Dr Mike Reznikov worked with Bill in Kiev on the human-Aura detection and correction

These famous scientist, Nobel laureates, quantum physicist, doctors, and researchers among many others are those that worked personally with and helped Bill to shape his theories and develop his life's work.

Low energy Synthetic Atom

This graphic shows how electronic charges are distributed across the surface of a molecule made of two cobalt atoms of mineral low level of energy

Proof that Synthetic compounds are not compatible with humans

High Energy Plant Atom

This graphic shows how electronic charges are distributed across the surface of a molecule made of two cobalt atoms after it has been in a plant and the energy of the sun makes the electronic charges more powerfull and dynamic

Sunlight photons act thru photosynthesis to make the plant and animal electrons have a higher energy level

In 9th grade we are taught about light. Light is made of photons. Photons are electro-magnetic radiation, particles in wave formations that can transfer energy. Quantum Electro-Dynamics QED tells us of how when a electron absorbs a photon the electron goes to a higher quantum energy state. When the electron releases a photon it goes to a lower state. QED tells us of virtual photons and just how all electron, proton, neutron movement is connected to the photon.

So quantum theory and the electrical science have made our lives so much better. They have given us telephones, television, computers and so many advancements to improve our lives. But any who take this new science into the understanding of the body human are attacked and persecuted.

Cancer is a mutation where the regulatory processes of the cells has been disrupted and altered. Normal cells have frequencies of 10 to the 5th Hz to 10 to the 12th. This sets a size limitation on the cells. The cancer cells have a different set of frequencies that make the size grow. More energy is spent on reproduction in cancer cells than normal cells, and less on metabolism. This is why they feed on sucrose right handed sugar more than the normal cells. This science is more fully discussed in the Cancer video from IMUNE. This video will present the science and the research proving the concept of the body electric.

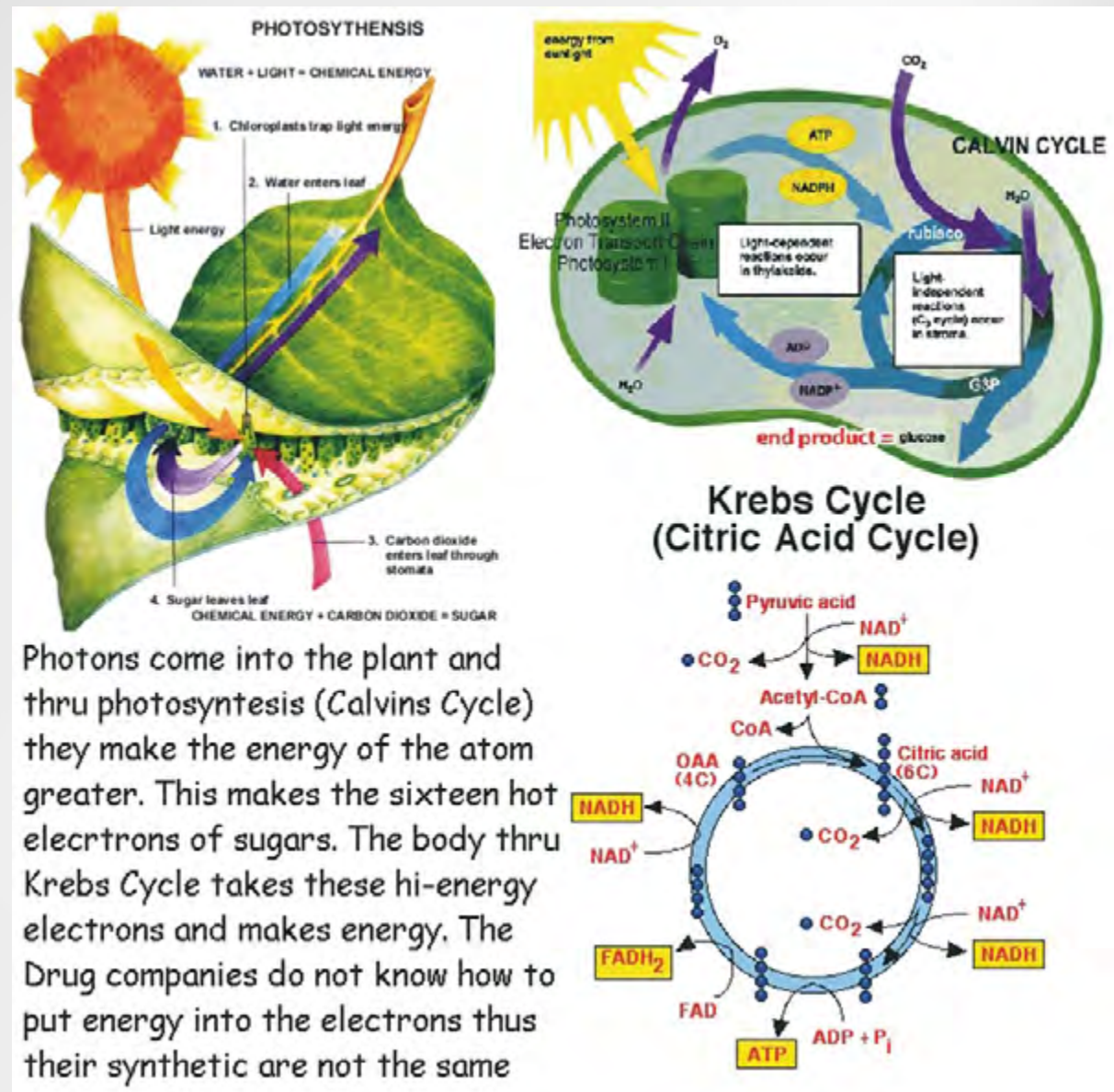

Voltammetry is the science of understanding how a substance's electro-magnetic field reacts with it's environment. A hormone has electrons and protons and how they are placed in a 3 dimensional space will determine how it exchanges electron-magnetic action and this is measured by measuring the 3 dimensional effect of it voltammetric field. The amount of charged particles is the amperage, the pressure or potential of the charged particles is the volts. Basic 7th grade physics. Every compound has its own individual and distinct voltammetric signature field.

There is another force that is undeniable, the power of the mind. We know from Quantum theory that twin photons can be separated to any distance and when we tell one photon something the other twin knows it instantly. At the birth of the universe there was a big bang where all of the matter of the universe came through a singularity in ten to the minus 43 of a sec. Thus at one point in our past history all things were conjoined and as such there is an ability of a quantic system to influence another. The observer effect of physics, the need for a double blind in medicine, and other evidence in the Proof movie. There is not a law of Attraction as some have said but there

is an effect of Attraction. There is a power of the mind (a known Quantic engine) to influence another Quantic system. Science has for a long time laughed at this and has purposefully avoided the proof of this true effect. And now science has become a search for funding not a search for truth. And since humiliation might interfere with funding most scientist still ignore the evidence. This is the height of ignorance to ignore.

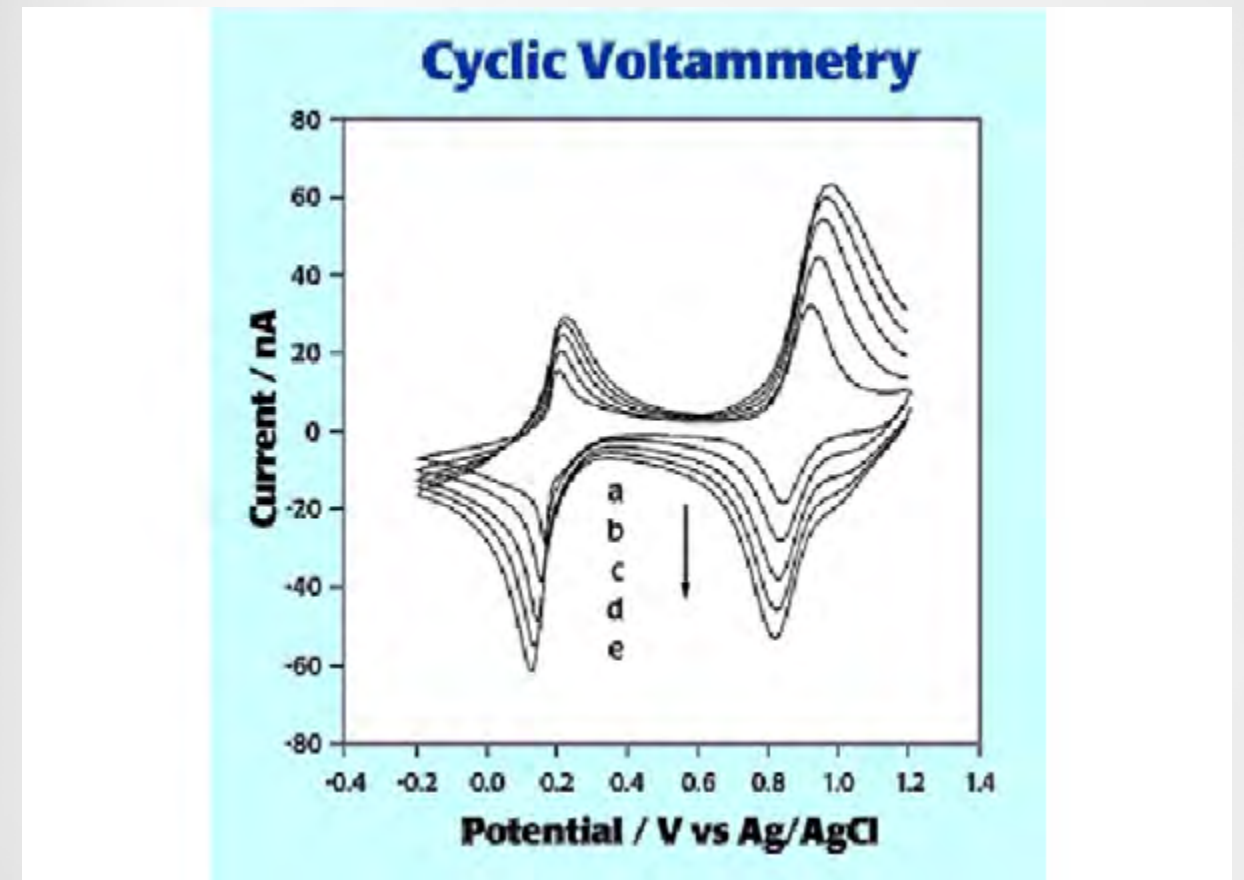

So with some simple science taught in our schools let us analyze the development of biology. First our fifth grade science tells us we are mostly electro-magnetic-static and Quantic fields. Non-living things mostly obey the laws of thermodynamics. The laws of thermodynamics teach us that energy cannot be created or destroyed, and that heat must flow from a hot body to a cold body. The hot coffee must succumb to the colder room and the two gradually equate their temperature.

Biological systems outwardly seem to disobey these laws by maintaining a temperature difference and not succumbing to the room temperature unless the die. Then as the Washington Post editor says, after death they lose their battle with room temperature. Biology is using a slightly different system of laws with a more quantic system than thermodynamic. REF PROMORPHEUS and NEOMORPHEUS

A living thing must be able to metabolize and reproduce in some fashion to be considered alive. Metabolism is taking in nutrients, taking the energy from them, and excreting the remainder as excretions of waste products. Reproduction is assembling new tissue for repair and also to propagate the species. The energy is Quantic electro-magnetic-static in nature as is everything. The basic energy of the electromagnetic radiation that is Visible light or Infrared heat. Plants

Much of the mistake of modern science and modern societies is to over value the words and the verbal process. Our society is presently over valuing the paper pushers and letting their need for words be more important than people. We need paper pushers and we need to have quality systems but there should be a requirement to try to minimize the over wordy and clarify the process of our society for everyone to understand not just the small minded paper pushers. This is especially true for biology and medicine.

The very process of life in an innate unconscious non-verbal Quantic electromagnetic field interaction. Words have little to do with it. But so-called modern medicine has overvalued the words. They wait for the patient to verbally notice something is wrong, go to the doctor office and announce what is wrong, answer the doctors' verbal questions, and receive verbal instruction. And yet this verbal exercise of medicine is only aware of one percent of one percent of one percent of one percent of one percent of one percent of one percent of one percent of the data. The body electric knows much more.

Patients words are influenced by their mood state. Patient's all lie, at least that is what Dr. House tells us on TV. Patients sometimes say things they think the doctor wants to hear, they cover-up things they don't want the doctor to know and very often they are completely out of touch with their own feelings and symptoms. Once I asked a patient if they had regular bowel movements. She said of course once a week like clockwork. Words are often the only intervention given to a doctor. In ancient China the doctor was sometimes unable to see the patient if he was of royalty. So the Chinese doctors had to develop new skills. Words have been a hallmark of medicine but it is also one of the greatest limitations. You can be really sick and have no symptoms or any verbal awareness of your sickness. Many people have tended to not only over value words, but some assume falsely there are only words.

Now as we learned in 5th grade everything is made mostly of electrons and protons. Photons are involved in all exchange of energy states. Now in some materials the electrons are tightly bound and are unwilling to allow electron exchange. In concrete the atoms are bound tightly and the electrons are not very conductive. In a metal like copper the electrons are quite willing to allow electro energy exchange and transport of electrons. So copper is a good conductor.

The organization of atoms and electrons determines the nature of the substance. Atoms seek to have a balanced outer level of electrons as per quantum law. This is the nature of atoms and it is calculated in the Mendeleev table of elements. Atoms seek to find the balance of the noble elements. This is the lesson from 10th grade chemistry. It is a simple lesson that tells us just how all atoms combine to make molecules. This lesson is based in Quantum theory. Those to say that quantum theory is not relevant to biology are expressing a rather concerning ignorance.

Molecules can be very very complex. But all of them are made of electrons, protons, neutrons etc held by Quantic forces. These molecules all have a structure of their outer electrons that can be assayed by the voltammetric signature. Voltammetry is the science of electrodes checking the individual style of electron and proton interaction. This is how every substance reacts to another, the outer electrons never touch but the field interaction as determined by voltammetry is a definition of how they work.

Every atom or molecule can be balanced, positive charge, negative charge, or combination of both. This depends on the amount of protons and electrons. This is Basic grade school science.

The charged particles that travel make a current flow. The amount of charged particles in the amperage, the pressure or potential of the flow is the voltage, the resistance to the flow is the resistance. All organisms use this electrical flow of charged particles for each and every biological process.

The electron is the smallest charged particle to move, and most of electricity is of the traveling electron. But protons and ions range from the small to very large.

The outer electrons of a plant are taken to higher energy states thru the QED phenomena known as photosynthesis. These electrons are most often stored in carbohydrates and natural sugars. The body use them for energy, making ATP from the electrons.

Energy transfer in the body takes place in many voltammetric ways. Water has free protons and free electrons and thus it is essential for life. Water does not conduct electricity, unless there are some mineral salts or electrolytes in the water. But as in the salt water the body has lots of water and electrolytes. Thus the body electric can thrive. REF

Fish like the shark swim and thus live in an electrolyte conductive medium. They develop electrical sensing systems, and can detect foods by their voltammetric signatures. In other land creatures like humans this electro sense is transferred to the skin and nose. But still voltammetric sensing of items are the basis for life.

We have the sense of sight for photon sensing, hearing for sound vibration detection, feeling for movement, pressure, heat, cold, balance, and the alkaline acid balance of chemicals. Smell and taste are voltammetric shape receptors sensors. (REF 2004 Nobel prize + electro sense). The largest gene family of our DNA is dedicated to the smell, over 3% in humans, 7% in some animals. All of our senses are electrical in action and transfer mechanism. Some of our sensory system is directed to our verbal or conscious mind and most to our non-verbal unconscious.

In the human body there is massive transfer of electrical signals. The flow of food entering the colon during digestion is based on static electrical attraction. Water facilitates the entire body electric. The body heat is photonic and also contributes to information transfer. If we look at the body human with today's modern science of QED and electronic physics, a whole new science develops a world different than the synthetic drug and surgery medicine we have today. Today's so called modern medicine is based on a 200 year old reductionism 17th century Newtonian antiquated physics. A true new modern medicine of the body electric opens the door to a more affordable, sophisticated, safer, and more efficient modern medicine. (REF Body Electric, Science over Convention)

There is resistance to the flow of electricity. Louis Ampere discovered amperage, Volta discovered Volts, and Dr. Ohm put a laws together to describe the relationship in terms of resistance. resistance is in Ohms and Ohms law states that voltage equals amperage times resistance. This is the first week of electronics class usually taught in 9th grade physics.

The right hand rule describes the fields around a flowing current. And it says that as a current flows like your outstretched right thumb, a magnetic field is made at 90 degrees like your out stretched forefinger, and a static field is made at 90 degrees like your outstretched middle finger. Thus the fields of electricity are described. This is the second week of electronics class usually taught in 10th grade physics.

So all electrical action or flow of electricity generates a three dimensional field, at least. So we called the process of measuring this field the trivector. This is a type of 3-dimensional voltammetry.

Voltammetry is the science of understanding how a substance's electro-magnetic field reacts with it's environment. A hormone has electrons and protons and how they are placed in a 3 dimensional space will determine how it exchanges electron-magnetic action and this is measured by measuring the 3 dimensional effect of it voltammetric field. The amount of charged particles is the amperage, the pressure or potential of the charged particles is the volts. Basic 7th grade physics. Every compound having it's own individual and distinct voltammetric signature field. REF Voltammetry

Volts times amps is a power index or what is known as Watts. Once we measure simple variables we can easily calculate a great variety of electrical forces. We can thus calculate volts, amps, ohms, reactance, susceptance, watts, capacitance, inductance, impedance, and other virtual mathematical calculations.

Knowing that reductionism has filed as a way to analyze the human body we can make more global measures of these energies of a human, compare them to norms, and then using safe micro-current stimulation change them.

We can detect and affect the body electric is safe and effective ways. The SCIO system is designed and registered to do just this. To detect and affect, EEG, ECG, EMG, GSR, electro-osmosis, trauma tissue, wounds, pain, charge stability, acid alkaline balance, voltammetric reactance of substances, oxygenation, hydration, redox potentials, electro-acupuncture, bio-resonance, super-learning, and other bio-electric functions. All from simple basic science taught in our schools today. REF clinical evaluation. Only with the 40 years of experience to sharpen and perfect the precision of the art. The first studies of Dr. Nelson on the body electric were done in Youngstown, Ohio. This ever dedicated scientist has artfully perfected this art of energetic medicine. All designed as a truly modern medicine to safely assay and treat the people.

The human body is a complicated intricate electrical assembly. It has a reactive set of fields that are driven towards life giving things like oxygen food etc. It is electrically repelled from toxins. This electrical field is processing the qualities of life such as metabolism and reproduction. Thus a vast ever changing system of electrical fields that are intricately interactive with the environment.

The human system is not a linear predictable or reduction type of system. Its vast complicated and elaborate functioning makes it a fractal complexity. As such it responds better to ever changing fractal stimulation not linear reductionistic simple stimulation.

So developing an electrical treatment needed some advances in technology. First a cybernetic loop of measuring, calculation, stimulation, measuring, calculation, stimulation, measuring, calculation, stimulation, and so on. All at biological speeds. Then a reactive system that reacts to fractal stimulation and an auto-focusing self adjusting stimulation. The body electric treats itself beneath the human awareness of the limited word area of the brain. And thirdly a way to measure the trivector field of items and then to measure the reactance of a person. All technological achievements of Dr. Nelson and Dr. Nelson alone.

The body has a reactive trivector set of fields. An item not living has a stable unchanging field. So to measure the substances fields, and then the person's reaction to these fields. A truly modern medicine is achieved, based on what we know of the body electric and basic high school physics.

Proton and Electron Balance

The fundamental particles of all things the electron and proton are electrical in nature. The body has to organize these properly to maintain health. The balance of negative (electron) versus positive (proton) is important. This is referred to as the Ph or proton pressure.

Acids accept electrons, because they are proton enriched. The simplest atom is hydrogen. It is one proton and one electron. When the electron is removed the hydrogen ion is a proton. If you have extra hydrogen atoms you have an acid. Like HCl hydrogen ion with chlorine hydrochloric acid. H2SO4, two hydrogen ions and sulfur and you get sulfuric acid. If you have hydrogen ions you are acidic.

Bases donate electrons, or bases accept protons. When you have too many electrons you are base and you will want to donate the electrons. A soluble base is also often referred to as an alkali if hydroxide ions (OH-) are involved. Bases have the hydroxide ion and most are referred to as blank hydroxide, sodium hydroxide, potassium hydroxide etc.

Bases can be thought of as the chemical opposite of acids. A reaction between an acid and base is called neutralization. Bases and acids are seen as opposites because the effect of an acid is to increase the hydronium ion (H3O+) concentration in water, where as bases reduce this concentration. Bases react with acids to produce water and salts (or their solutions). The whole process is electrical. Thus life is electrical.

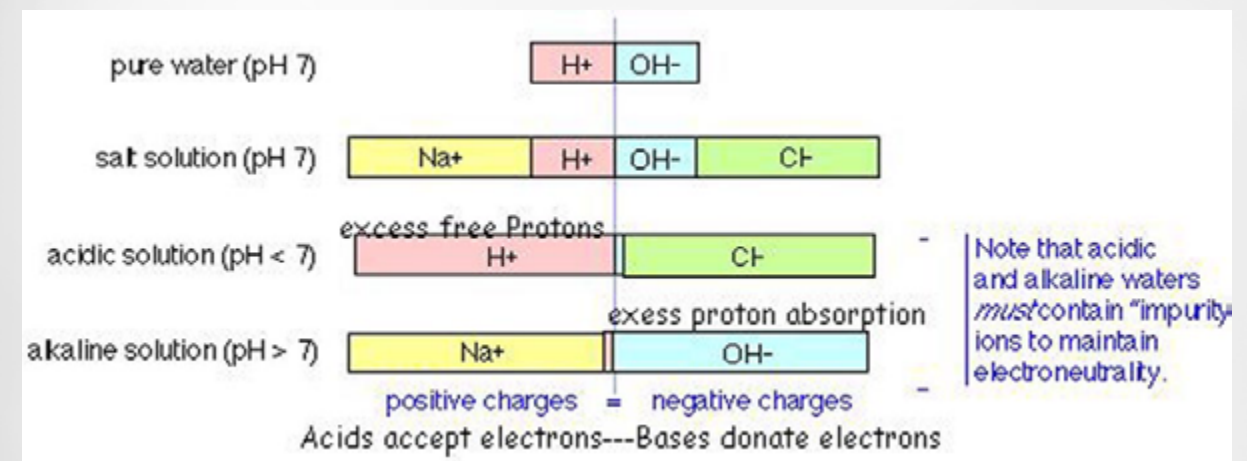

Charge Balance: all ionic solutions must contain equal numbers of positive and negative charges. But not an equal number of free protons or free proton absorbers

Humans have been familiar with acids and bases for thousands of years. They didn't know the exact chemistry but they knew a lot about them.

The word acid comes from Latin word acidus meaning sour, sharp, or tart taste. Vinegar as you might remember means sour wine. Vinegar is acetic acid in water. Acetum is a historical name for vinegar and comes from the word acere meaning to be sour.

ALKALI, a salt. (Arabic.) and qali is the name given to the ashes of the plant glass-wort (Salicornia), which abounds in soda.

Alkaline items are:

1. Capable of neutralizing an acid. Bases are alkaline.
2. Relating to an alkali compound.
3. Having a pH greater than 7.
4. Having a relatively low concentration of hydrogen ions.

Pure water consists almost entirely of H₂O molecules loosely bound in a network-like structure in which individual molecules are constantly changing partners. Water molecules exhibit a very slight tendency to dissociate ("ionize") into hydrogen ions and hydroxide ions:



but the extent of this reaction is severely limited by the fact that the reverse of this reaction is much more rapid, so that on the average, only about two out of every million H₂O molecules are dissociated. No electrical device or chemical additive is capable of increasing these ion concentrations in pure water above this very minute level which is so small that for most practical purposes pure water can be considered to be ion-free, as evidenced by the fact that it will not conduct an electric current. It only conducts electricity when there are salts or impurities in the water and since all water has some impurities there is conductivity. No electrical device is capable of increasing these ion concentrations but we can affect the flickering rate of dissociation association.

Electrolysis

Electrolysis refers to the breakdown of a substance by passing an electric current through it. This is accomplished by placing a pair of oppositely-charged electrodes (usually of platinum or some other unreactive metal) in the solution. Positive ions that find themselves close to the negative electrode will acquire electrons, and negative ions near the positive electrode will lose electrons. In the case of pure water, the reactions are as follows:

At the negative electrode:

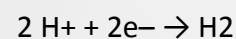

... but since the H⁺ ions come from water, the overall reaction is

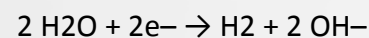

at the positive electrode:

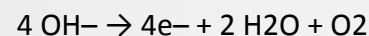

... but since the OH⁻ ions come from water, the overall reaction is

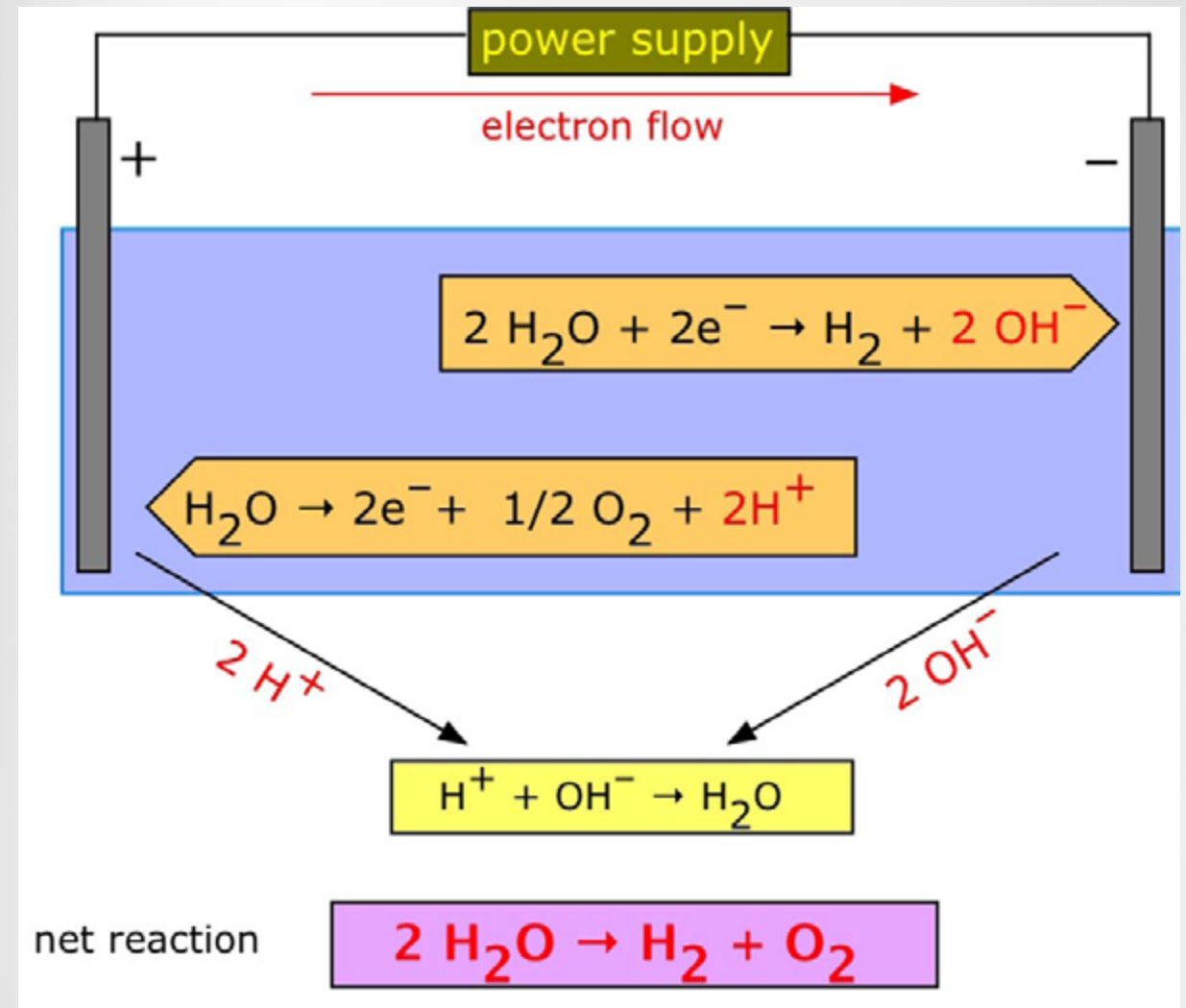
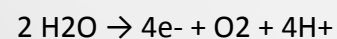

Note that the consumption of H⁺ ions at the negative electrode leaves an excess of OH⁻ ions in the vicinity of this electrode, making the water in this region alkaline. Similarly, the consumption of OH⁻ ions at the positive electrode makes the water near this electrode acidic. If the regions near the two electrodes are surrounded by a semi-permeable barrier that inhibits diffusion of these ions into the bulk of the water, small local excesses can build up, but with pure water to start with, the acidity or alkalinity would be undetectable. Eventually the H⁺ and OH⁻ ions find each other and recombine:

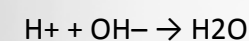

... so the net reaction for the electrolysis of pure water is simply the production of gaseous hydrogen and oxygen:

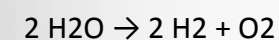

... leaving the pH of the water at 7.0, just as it was before electrolysis.

In other words, electrolysis cannot change the pH of pure water. None of the sites hawking these "water ionizers" mention this, of course, nor do they bother to tell you the even worse news:

Pure water cannot undergo significant electrolysis

One more thing about the electrolysis of pure water: because of the very small number of ions in pure water, it conducts electric current very poorly, so the process is extremely slow and inefficient. This means that if your water supply is free of mineral impurities, no significant amount of electrolysis will occur.

Will water that purports to be "ionized" or "alkalized" make me feel better, younger, more vigorous, etc.?

Quite possibly, yes! Studies have shown that placebos can relieve the symptoms in about 40 percent of those who suffer from chronic ailments. They are probably even more effective for those who are inclined toward "alternative medicine" or the "wellness" industry. In other words, if you "believe" that something might help, it may well do so, and the more people are made to pay for it, the more eager they will be to have their beliefs confirmed. (Remember those Monty Python apartment towers that would remain standing only as long as the residents maintained their faith in them?)

Acid-base chemistry in physiology

Acid-base chemistry plays a crucial role in physiology, both at the level of the individual cell and of the total organism. The reasons for this are twofold:

- Many of the major chemical components of an organism can themselves act as acids and/or bases. Thus proteins contain both acidic and basic groups, so that their shapes and their functional activities are highly dependent on pH.
- Virtually all important metabolic processes involve the uptake or release of hydrogen ions. The very act of being alive tends to change the surrounding intracellular pH (usually reducing it); this will eventually kill the organism in the absence of buffering agents.

About two-thirds of the weight of an adult human consists of water. About two-thirds of this water is located within cells, while the remaining third consists of extracellular water, mostly interstitial fluid that bathes the cells, and the blood plasma. The latter, amounting to about five percent of body weight (about 5 L in the adult), serves as a supporting fluid for the blood cells and acts as a means of transporting chemicals between cells and the external environment. It is basically a 0.15M solution of salt (NaCl) containing smaller amounts of other electrolytes, the most important of which are bicarbonate (HCO₃⁻) and protein anions.

Respiration, the most important physiological activity of a cell, is an acid-producing process. Carbohydrate substances are broken down into carbon dioxide, and thus carbonic acid:

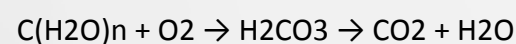

Interestingly, the ingestion of "acidic" foods can make the body more alkaline. This comes about because the weak organic acids in such foods are partly in the form of sodium or potassium salts M+A⁻. In order to maintain charge balance, some of the CO₂ produced by normal metabolism of these food acids must be converted into bicarbonate (that is, M⁺ HCO₃⁻) which is a weak base.

Maintenance of acid-base balance

It is remarkable that the pH of most cellular fluids can be kept within such a narrow range, given the large number of processes that tend to upset it. This is due to the exquisite balance between

a large number of interlinked processes operating at many different levels.

Acid-base balance in the body is maintained by two general mechanisms: selective excretion of acids or bases, and by the buffering action of weak acid-base systems in body fluids.

Over a 24-hour period, the adult human eliminates the equivalent of about 20-40 moles of H⁺ as carbonic acid H₂CO₃ which breaks down into CO₂ (exiting via the lungs) and H₂O (through the kidneys.) In addition, the kidneys excrete perhaps 5% of this amount of acid, mostly in the form of H₂PO₄⁻ and NH₄⁺. Owing to their electric charges, these two species are closely linked to salt balance with ions such as Na⁺ or K⁺, and Cl⁻.

The major buffering system in the body is the carbonate system, which exists mainly in the form of HCO₃⁻ at normal physiological pH. Secondary buffering action comes from phosphate, from proteins and other weak organic acids, and (within blood cells), the hemoglobin.

Disturbances of acid-base balance

Deviations of the blood plasma pH from its normal value of 7.4 by more than about ±0.1 can be very serious. These conditions are known medically as acidosis and alkalosis. They can be caused by metabolic disturbances such as diabetes and by kidney failure (in which excretion of H₂PO₄⁻, for example, is inhibited.)

Numerous other processes lead to temporary unbalances. Thus hyperventilation, which can result from emotional upset, leads to above-normal loss of CO₂, and thus to alkalosis. Similarly, hypoventilation can act as a compensatory mechanism for acidosis. On the other hand, retention of CO₂ caused by bronchopneumonia, for example, can give rise to acidosis. Acidosis can also result from diarrhea (loss of alkaline fluid from the intestine,) while loss of gastric contents by vomiting promotes alkalosis.

Water is H₂O two Hydrogen atoms with one Oxygen. The hydrogen atoms are protons. At room temperature or so one of the hydrogen ions can split from the other hydrogen and oxygen. So there is a free proton and a hydroxyl ion. Then there is rejoining and then another separation. This cycle is called the flickering rate or the zeta frequency of the water.

There is an electrical nature of water, and thus an electrical nature of the body human. As we see salts can change the balance of the protons and hydroxyl ions. When there is a shift towards excess protons the compound is acid. When there is a shift towards fewer protons the system goes alkaline. The body needs to be slightly base over all, and each part has an individual Ph component.

The blood has to be slightly alkaline for health. We should be 7.4 Ph. When we get 7.2 we get sick and at 7.0 we can die. If we get 7.6 we get sick if we get to 7.8 we can die. There is a critical balance of ph for life.

What makes us go acid is acid forming foods with an acidic ash component. These are close to the same culprits of our right handed sugars. Thus a meat, potatoes, corn, beer, rice, and all of the dextrose sugars are the main culprits that drive our bodies to be acid. Stress toxins, radiation all make us also go acid and this can cause or aggravate disease.

What makes us go alkaline is fruits and vegetables. So we can see that today's lifestyle makes us go acid and 85% of the ill are to acid. The main solution is in the foods we eat and the alkaline ash they leave as we process the food.

It is a struggle to maintain the balance of Ph for health. Many have designed water machines to make water more alkaline. These devices will run electrons thru the water from electrodes. This is a variation of electrolysis. The acidity and alkalinity of the water is thus changed and people are told to drink the water for health.

There are two sides of the argument with neither being decisive. I wrote a book on water that you can get from IMUNE. ("Water"). In this book I point out the incredible power of water and its inconceivable complexity. I point out 64 anomalies where water is different than other chemical we know here on earth. There are over 64 different special powers of water. Anything you do to get a patient to drink more water is good for their health. So if they are told to buy a device that makes healthy water and to drink it, it will benefit their health. This is worth the money.

There is no good evidence that drinking the water from these Ph devices can cure cancer. I have asked for the studies and only received hypothetical theory papers, not studies.

I also wrote a small book on the two camps of medicine. "Evidence based medicine versus Natural Medicine". Evidence based medicine is designed by hardnosed cheap penny-pinching frugal people who want to make sure that they do not waste their money. In evidence based medicine there is a great need to prove it works at a high degree of statistical accuracy. You must get 19 out of 20 to respond for statistical evidence. This is the way of government regulatory agencies that employ such overly frugal picayune people.

Evidence based medicine thus cost money for the statistical evidence, and Evidence based medicine must be harsh to get 19 out of 20 statistical results. (for the small minded little dick head agent geek this is just a colloquial reference to the 95% alpha needed for statistical significance of a study.) Evidence based medicine focuses on the results of how it works and losses sight of safety. In a study they measure the effect desired for statistical significance but only observe side effects. Thus side effects are found out later in the process usually after several people have died.

Evidence based medicine is costly and investors are needed. Investors care only about one thing, profit, not safety. So the need to be frugal with our money leads us to a medicine where safety is not first or even second on the priority list and costs mount up as safety dwindles. This leaves us with the mess health care (or should I say Diseases care) has left us with.

The other camp, Natural medicine, has safety first as it's prime directive. Natural medicine does not want to hurt a single person in any way. So, safe natural soft not statistical methods are sought. The book "Evidence based medicine versus Natural Medicine" will discuss thus thoroughly.

But here we see a differing opinion on the water devices. The Evidence people like the Free trade people do not want people to spend their money on things unproven to work. This is their job, to see that people's pocketbooks are safe. Some feel that the drug companies are behind this and that the drug companies do not want the competition of alternative therapies to hurt them.

The natural people feel mistakenly that they have freedom of speech to say what they want and to tell their personal stories to help market the water devices. Their freedom of speech should not be used as a marketing tool to pretend there is evidence when there is not. People can tell true stories, not embellished ones, and still not in a pure marketing fashion. Science needs to be done and statistics is needed.

If someone tells you that drinking water from an expensive alkaline water device cures cancer,

challenge him. I have seen no such evidence, and even the stories I have heard are suspect. I welcome some science, but after requesting it for years I am still waiting.

Many of the procedures in this book are examples of natural therapies that do not have the money for proper statistical proof. But you must decide on the use. We try to develop safety first, but with the need for success. But still the only person to correctly do research on the natural vinca, not the synthetic form, is me. I see both sides of the argument and there is a vital need to do studies. The cancer study at the end of this book will tell you of our study where over 7500 cancer patients were treated by therapies in this book and there were over 2500 cures, not 19 out of 20 but nobody does with cancer. I write this book from my heart and mind to give you natural answers to a big question. What to do if you have cancer.



The water devices have no real proof of their efficacy. But water is good, more water is better. But at 3 gallons of water in 30 minutes is a poison, so watch out. Don't believe everything you hear. Yes the drug companies are scared. Big money, Big Sugar, Big Tobacco, Big Pharma, Big Media all hate me and they see me as the enemy. I am just a gal with clarity of mind.

Acid or alkaline water is not going to produce a change in you Ph. The mouth, stomach and small intestine are designed to buffer excess acid or alkaline food or drink. If not acid orange juice would kill you. Your Ph is determined by the acid or alkaline ash or last by product of the foods and drinks you consume. Orange juice is acid going in but it is an alkalizing food. Orange flavored sugar water or orange drink as it is called, is acid going in but leaves an acid ash so it is an acid forming food. It is the end result of the food or drink that concerns it's acid or alkaline effect. Water is neutral.

So to correct your Ph. If you are too acid as most cancer patients are avoid the high glycemic acid forming foods and eat the fruits and vegetables we indicate in this book. wheat grass juice is a very good quick alkalizer.

If you are alkaline, drink lots of cranberry juice (all cranberry juice has sugar added) this is acid forming and will help the urinary infection that is probably causing you alkalinity. Potato juice and potato soup are good. Watermelon and watermelon juice is also good for a day or two. A rice day, just rice for a day nothing else, is also a good treatment, as is grape juice. If there is a chronic skin affliction with alkalinity, just grapes, and grape products for three days is helpful.

Stabilize your breathing exercise and get good yoga, meditation and relaxation. Drink lots of good filtered water for either acid or alkaline conditions.



Scientists have engineered a new species combining Pig and Human genes to use for blood serum



PIGS will eat anything including urine, dirt, decaying animal flesh, maggots, or decaying vegetables and left overs of what people ate. They will even eat the cancerous growths off other pigs or animals. You are killing yourself slowly by eating pig. Pork is like death. The meat and fat of a pig absorbs toxins like a sponge. Their meat can be 50 times more toxic than beef. Pigs don't sweat so the toxins remain within its body and in the meat. And then when a pig is butchered, worms and insects take to its flesh sooner and faster than to other animal's flesh. In a few days the pig flesh is full of worms.

For some people pig is so delicious they must eat it. In the old days we would only eat pig once a year as a celebration usually the fall or winter to celebrate the harvest. Then it became twice a year to celebrate the spring. Then as people became more affluent they started to celebrate monthly then weekly and some daily. If you eat pig very often it will affect your health. Once or twice a year is not so much of a problem if it is well raised pig and well cooked.

Towards a Cure for
Degenerative Disease
with the new science of
Electronics and Quantum
Electrodynamics

ANOTHER GIFT FROM THE *Angel*

QUANTUM ELECTRO DYNAMIC BIOFEEDBACK

The atoms of all things are made of mostly electrons and protons and other miscellaneous sub atomic particles. Everything has an electric field around it because of the electrons and protons that make it up. The workings of these atoms is covered in chemistry. In chemistry we learn that most atoms have imbalances in their outer electron shell. So they seek atoms that can help to fill these shells. These shells are only explained in quantum physics. All things are only describable with quantum physics. The electrons are placed around the nucleus of the atom. If the nucleus is the size of a golf ball the electron is less than the head of a pin and about a half mile away from the nucleus. The truth is that we are mostly empty space. Space that is full of fields. Fields that interact and make biology possible. To study biology we must study these fields. But these fields are only explainable through electronics or quantum physics.

What we call modern medicine is not modern at all. In fact it is based in antiquated science of thermodynamic Newtonian physics and old style chemistry. Today a truly modern science is based in non linear fractal quantum electrodynamics. We need a more modern medicine. Traditional medicine has just been a puppet for the SYNTHETIC drug companies.

Everything has an electric field around it because of the electrons and protons that make it up. We all know about these fields today especially if you have traveled and had to go thru a metal detector. The metal detector senses the magnetic field of metal. Metals have a strong magnetic field. Other substances have a weaker or paramagnetic field such as water. It has weak field. Some things have an almost nil field and some substances such as bismuth have a negative field. But everything has an electric field around it because of the electrons and protons that make it up.

In a major Medical University Study done with over 100,000 patients, 7,000 patients with cancer were treated by qualified QED biofeedback therapists. There was over a thirty percent cure rate. The future of medicine is in modernizing away from SYNthetic chemistry towards the body Electric and QED.

Meats in your Diet

Humans were once complete herbivores. All Animals need amino acids to survive. Amino acids can be found in plants, but for humans no one plant provides all of the amino acids we need. So we must use a variety of plants and to be a complete vegetarian it takes skill to mix plants to get the amino acids. Humans had evolved to wander from bush to bush. Then humans developed hunting tools and learned to eat fresh meat. But degenerative disease comes in with the invention of fire and cooking.

Cooking meats makes carcinogens. Open flame char broiling the worst. When we burn anything carcinogens are formed. Burnt compounds are carcinogenic whether they are inhaled into the lungs like smoke, or on a food taken into the digestive tract. If it is burnt don't eat it. Cooking destroys the good fatty acids, the enzymes, and the vitamins. The more cooked the less nutrition, the more disease.

Humans have an oral teeth design of an herbivore. The TMJ (Temporal Mandibular Joint) of the jaw is designed for plants and chewing, just like a cow. Carnivore teeth and jaw are for ripping and swallowing quickly. We are designed to chew.

Humans have a digestive tract equivalent to the gorilla (an herbivore). Carnivores have short sixteen foot long digestive tract to dissolve the meat. Herbivores have longer tracts over 25 feet long, like the human. Longer tract is designed for the vegetables. Humans have an herbivore digestive tract.

Humans have an herbivore set of legs. If we had to catch an animal for lunch with just our bodies we would mostly starve. Before tools were invented our ancestors had to eat plants. We cannot run fast enough, swim fast enough or jump high enough to feed our families without weapons.

After the recent invention of weapons (15,000 years ago) humans have developed a sense to eat meat. Humans got exercise hunting. Humans have developed a carnivore taste, with an herbivore body. So we have become Omnivores. No human can live healthy on just dead animal flesh.

The Price Pottinger Institute of San Diego is designed to show the power of the work of these two men. Their genius work goes unheralded today. Dr Price showed that degenerative disease is relatively unknown in societies where they do not have dextrose sugar and cooking. The Eskimos of the north have no dental problems of degenerative disease till cooking and dextrose sugar are put into their diet. Several other societies were also found to have similar results. Cooking and dextrose sugar mark the beginning of degenerative disease. The famous Pottinger cat study showed this. Please review.

Price-Pottenger Nutrition Foundation

Weston A. Price, DDS Francis M. Pottenger, Jr., MD

What lies beneath the food pyramid?

"Let your food be your medicine" said Hippocrates, the Father of Medicine, who compiled a list of over four hundred herbs and their uses. Herbs, spices and other nutritional substances are the oldest form of medicine known to man.

Drs Price and Pottenger found that sugar and over cooking create health risks. Only with dextrose sugars and cooking do we start to see degenerative disease form. The cooking weakens the enzymes and destroys fatty acids and vitamins. Dextrose Sugar weakens the immune system and nerves.

Weston A. Price 1870-1948

It turns out that the cooking and the smoke are the leading carcinogenic compounds. In Japan where Shabu Shabu (cooking only in boiled water) was found to limit disease. Stir fry cooking or just simple minimal cooking was shown to also decrease degenerative disease. The heat and smoke make carcinogenic toxins. The diseases of parasites, injury, and infections need to be controlled to limit disease in general. But cooking destroys nutrients, and makes carcinogens. Dextrose sugar weakens the immune system. And this is the start of degenerative disease.

NUTRITION AND PHYSICAL DEGENERATION

Source: Nutrition and Physical Degeneration, by Weston A Price
 Photos used with Permission of Price-Pottenger Nutrition Foundation
<http://www.price-pottenger.org/>

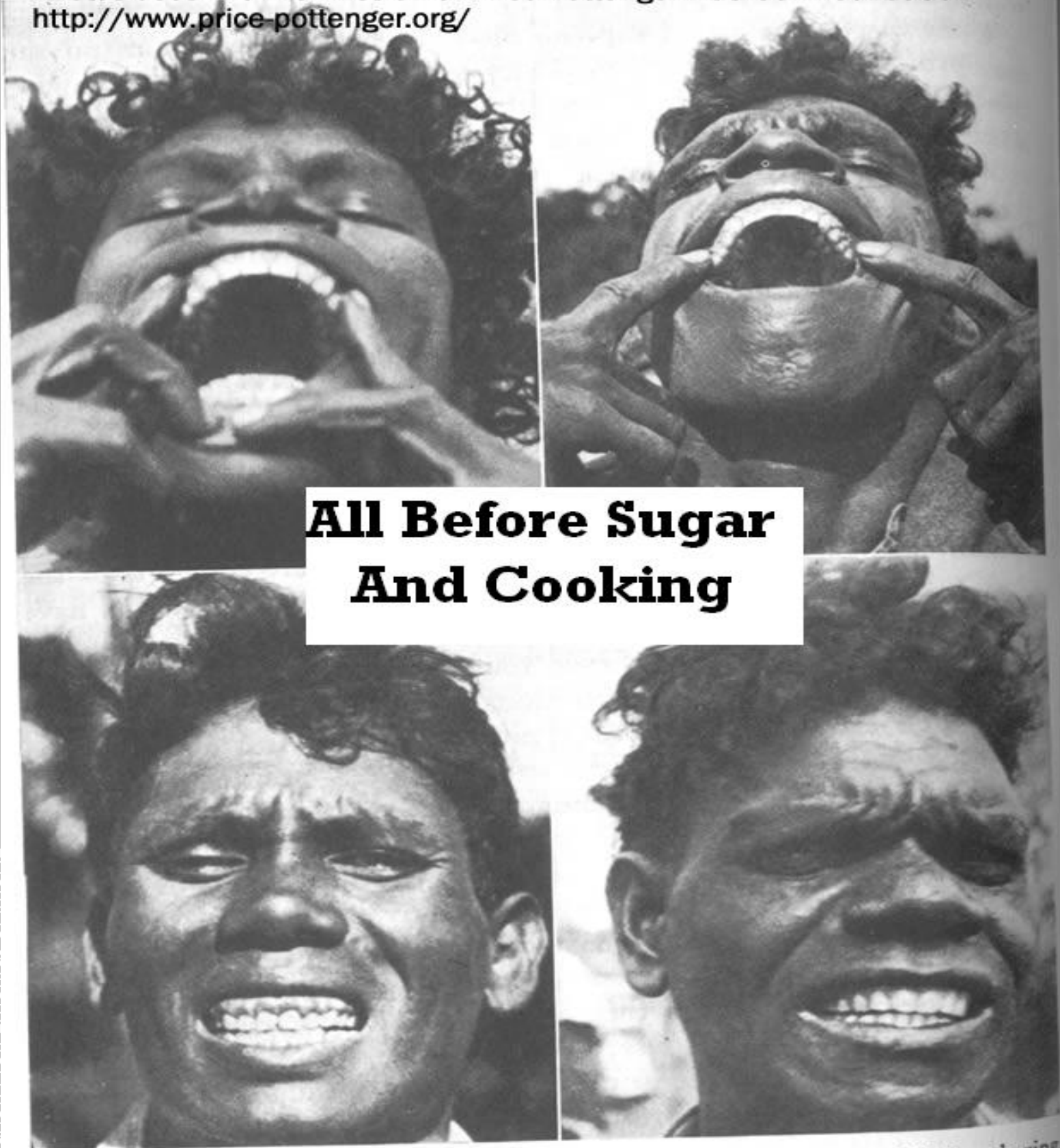

FIG. 53. No other primitive race seems to deserve so much credit for skill in obeying nature's laws as these primitive Aborigines because of the perpetual drought hazards of much of the land they live in. Half of Australia has less than ten inches of rain per year. Note the magnificent dental arches and beautiful teeth of these primitives. Tooth decay was almost unknown in many districts.

SIX-PHASE TABLE

Organ system	HUMORAL PHASES			BIOLOGICAL DIVISION	CELLULAR PHASES		
	Excretion Phases	Inflammatory Phases	Deposition Phases		Impregnation Phases	Degeneration Phases	De-differentiation Phases
Skin	Episodes of weeping	Acne	Nevi	BIOLOGICAL DIVISION	Allergy	Scleroderma	Melanoma
Nervous system	Difficulty concentrating	Meningitis	Cerebrocalciosis		Migraine	Alzheimer's disease	Gliocarcinoma
Sensory system	Tears, otitis	Conjunctivitis, otitis media	Chalazion, cholesteatoma		Induritis, tinnitus	Macular degeneration, anosmia	Anaurosis, malignant tumor
Locomotor System	Joint pains	Epicondylitis	Exostosis		Chronic rheumatoid arthritis	Spondylitis	Sarcoma, chondroma
Respiratory tract	Cough, expectoration	Bronchitis, acute	Silicosis, smoker's lung		Chronic (obstructive) bronchitis	Bronchiectasis, emphysema	Bronchial carcinoma
Cardiovascular System	Functional heart complaint	Endocarditis, pericarditis, myocarditis	Coronary heart disease		Heart failure	Myocardial infarction	Endotheliosis
Gastrointestinal System	Heartburn	Gastroenteritis, gastritis	Hyperplastic gastritis		Chronic gastritis, malabsorption	Atrophic gastritis, liver cirrhosis	Stomach cancer, colon cancer
Urogenital System	Polyuria	Urinary tract infection	Bladder stones, kidney stones		Chronic urinary tract infection	Renal atrophy	Cancer
Blood	Reticulocytosis	Leucocytosis, suppuration	Polycythemia, thrombocytosis		Aggregation disturbance	Anemia, thrombocytopenia	Leukemia
Lymph System	Lymphedema	Lymphangitis, tonsillitis, lymphadenitis	Lymph-node swelling		Insufficiency of the lymph system	Fibrosis	Lymphoma, Hodgkin-/non-Hodgkin-lymphoma
Metabolism	Electrolyte shift	Lipid metabolism disturbance	Snout, obesity		Metabolic syndrome	Diabetes mellitus	Slow reactions
Hormone system	Glucose sensation	Thyroiditis	Goitre, adenoma		Hyperthyroidism, glucose intolerance	Menopausal symptoms	Thyroid cancer
Immune System	Susceptibility to infection	Weak immune system, acute infection	Weak reactions		Autoimmune disease, immunodeficiency, chronic infections	AIDS	Slow reactions
	Alteration*	Reaction*	Fixation*		Chronic Forms*	Deficits*	Decooping*
Psyche	Functional psychological disturbance, "nervousness"	Reactive depressive syndromes, hyperkinetic syndrome	Psychosomatic manifestation, neuroses, phobias, neurotic depression	Endogenous depression, psychosis, anxiety neurosis, organic psychosyndrome	Schizophrenic defective states, mental deficiency	Mania, catatonia	

Since animals have the amino acids locked in their proteins, we can get the amino acids by eating animal flesh. But our digestive system needs to digest the protein to get the amino acids. This is difficult as we age or are under stress.

We grow the most during our first year of life when we double or more our weight and height. Mother's milk is the perfect food, and it is only 2% protein. A gorilla has an identical digestive system to us, he is 600 lbs and can throw a car. His diet is 2% protein. The massive cow, horse, elephant have diets 2% protein. We do not need large amounts of protein. We need amino acids. We can get all the amino acids from bean sprouts. And if someone craves meat, a handful of bean sprouts will usually satisfy them in about 15 min. But culturally our taste buds like heated cooked dead animal flesh. The protein rush and heated fats are tasty. Thus carnivores crave meat. And humans have evolved to be omnivores.

The major dangers of meat are processed chemicals, carcinogens from cooking, excess bad fats and cholesterol. Putrefaction of red meat in the colon makes it more dangerous. Our digestive system is not designed to take in large quantities of meat. When we improperly combine foods and disobey the rules of the stomach we make everything worse. So eat meat at your caution. The less cooking the better, the less meat the better, the less chemicals the better.

Figure 2. Dose-response curve showing the quantitative features of hormesis. NOAEL, no observed adverse effect level.

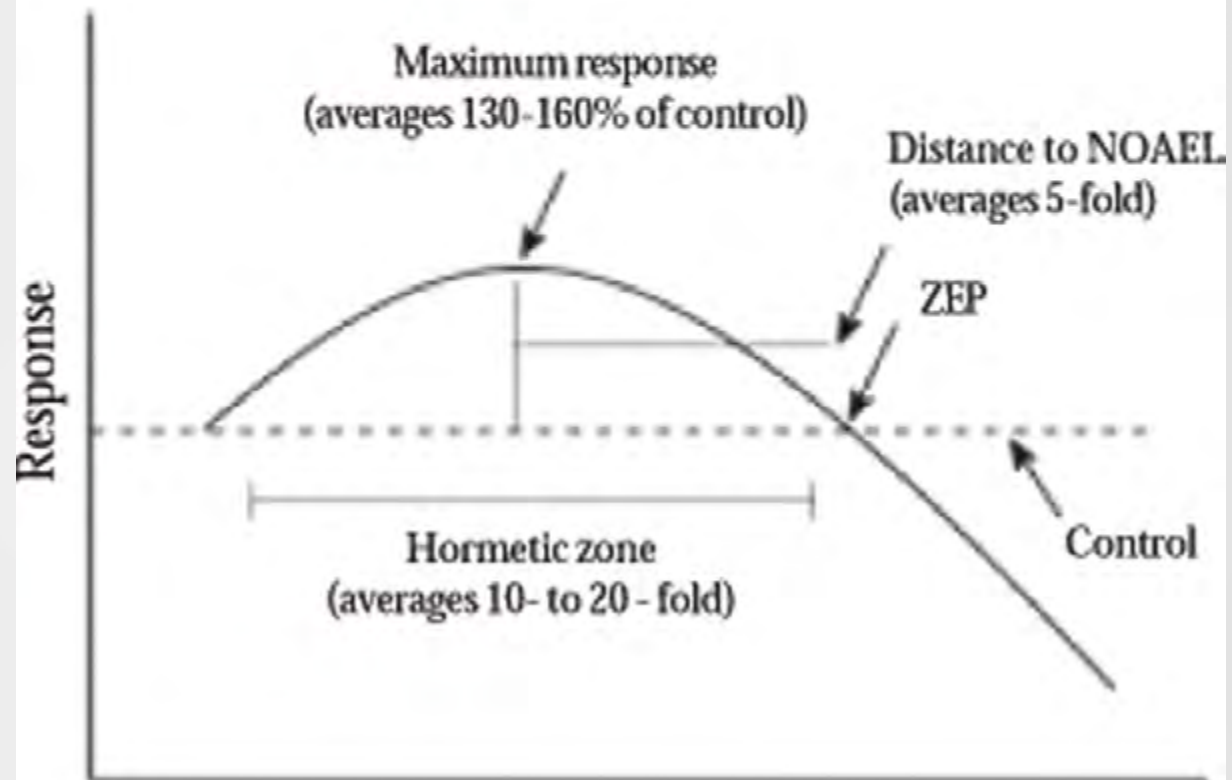

DID YOU KNOW?

Lean cuts of meat such as chicken breast are lower in salt than processed meats such as ham and bacon. Too much salt can raise blood pressure in adults and children so choose lean meat more often than processed meat



Eating Healthy is good for many reasons. It helps you feel better, helps your body's immune system stay strong and wards off illness in general. You have more energy, better concentration and a heightened overall sense of wellbeing. A healthy diet consists of many things, including the meats you consume. If you are like many other Americans, your meat diet probably includes higher fat meats, such as different types of red meat. Making your diet healthier can start with replacing these higher fat meats with healthy alternatives. This article will help you do just that.

GunShots Ring out on the Street Again



Difficulty: Moderate

Instructions

How to Distinguish Between High-Fat Meats and Healthy Alternatives

Step 1

Avoid all processed meats. Like bologna, lunch meats, Hot dogs, sausage, any meats using nitrites and or nitrates to make into a congealed package.

Step 2

Avoid pork as much as possible. Reserving it for maybe once or twice a year as a holiday celebrations.

Step 3

Avoid excess fatty meats and meats raised in toxic areas with too many chemicals. Organic meats are then the best. Learn what other meats and alternatives are available for you to eat that have less fat content and are healthier. Most of the healthier meats will be white meats or red meats that are lean. Some of these white meats include veal and chicken. ***You can also use meat substitutes such as tofu or veggie burgers.***

How To Eat the Healthy Alternatives, make meat the second dish to serve at a meal. Instead of a side vegetable, use meat as a side dish.

Step 1

Start with hamburger. The easiest way to make a modification here is to use a leaner organic type of beef. If the meat you currently use for hamburger is 75%/25% lean, switch to 90%/10% lean. Or, you could consider a different type of burger, such as a veggie burger or turkey burger. Use spices to add flavor. Use seafood, chicken, turkey, duck, buffalo, ostrich and others more. Duck fat is less likely to go into human fat than the others. So use when there is a fat craving person at the table. But use organic, and use sparingly and wean them down.

Step 2

Change your pasta dishes. Use vegetable enhanced whole wheat pasta. If you were going to make Hamburger Helper, try making Chicken Helper. If you were going to make spaghetti and meatballs with hamburger, try using veal or lamb instead. Veal is actually considered a white meat and is much healthier for you. The young animals have less fat. And buffalo, ostrich, and other low fat meats are an excellent choice.

Step 3

If you can't do away totally with your hamburger, eat it in less quantities and mix it with other things. Instead of making a veggie burger with no meat, try mixing in vegetables with the hamburger to make it healthier.

Step 4

Eat more seafood. Seafood has very low fat content. Just be careful not to add too many seafood dishes with a high cholesterol content, like shrimp and lobster. Your best bet is to eat lots of white fish, such as haddock, pollock and cod. The deeper the sea fish the more healthy oils. So Orange Ruffly is an excellent choice.

Step 5

Take any meal you used to eat and switch the meat from a higher fat one to a leaner alternative. If you used to eat meatloaf and mashed potatoes, make a meatloaf with chicken instead.

Step 6

Eat dishes that have no meat in them. Substitute some bean sprouts. There is no need to have meat for every meal. For lunch, instead of that Philly steak sandwich, try just having a large garden salad with mixed green lettuce, tomatoes, cucumbers, broccoli and carrots. Have whole-wheat bread with the salad to help make the meal more filling.

Step 7

If you are still hungry after the salad and bread, add soup to the meal. The soup could be one with beans, like meatless chili. A baked potato soup or noodle soup can also be hearty and satisfying.

Step 8

If you run out of ideas, look for cookbooks that deal with healthy alternatives to red meat. You can find e-books online or buy books at a popular bookstore. You can often get discounts on book purchasing by joining rewards programs at bookstores, such as by joining Borders Rewards at

Border's Bookstore. If your budget is extremely tight, check out books from the public library.



COUNTERTHINK

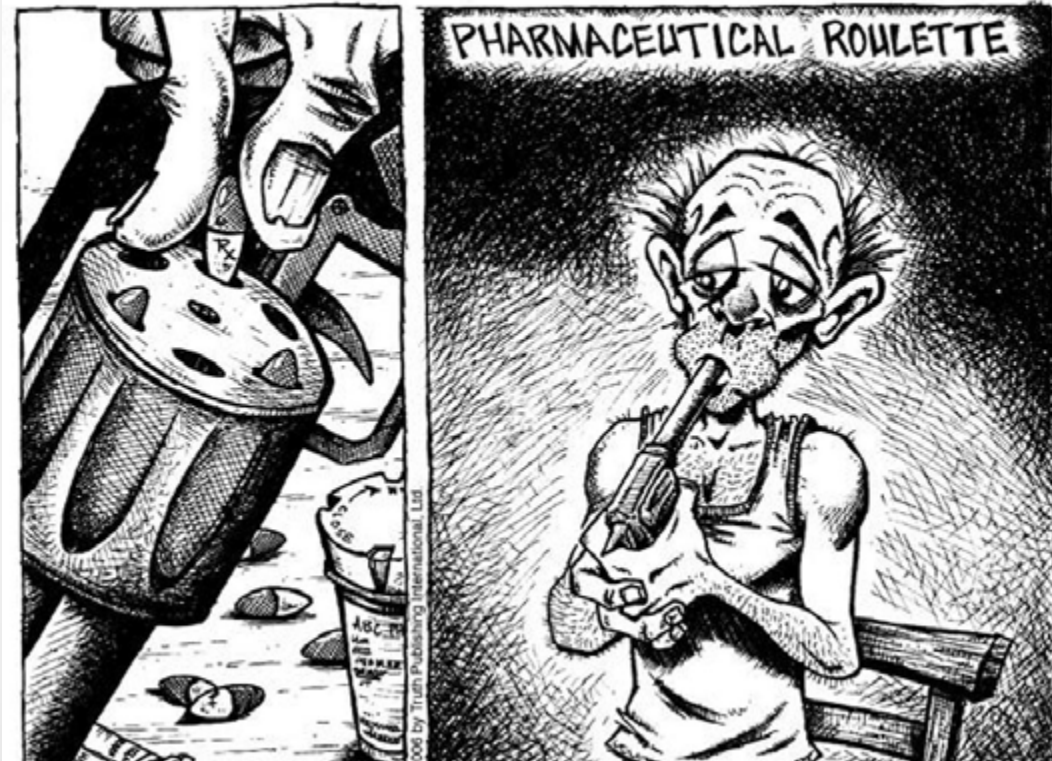

Tips & Warnings

- The more creative you are, the more alternative ideas you will come up with for replacing your higher-fat meats with healthy alternatives. Use spice.
- If you run out of creative ideas, talk to other people and ask them what recipes they use.
- It can be helpful to consult a physician when making major modifications in your diet.
- Be wary of cutting out meat from your diet altogether. There are many essential nutrients and minerals found in these meats that aren't available elsewhere in your diet.
- When switching your diet choices to something new, be careful that you don't create vitamin deficiencies by cutting out key sources of important nutrients. If you get rid of a red meat that was your sole source of iron, replace it with clams or certain cereals.

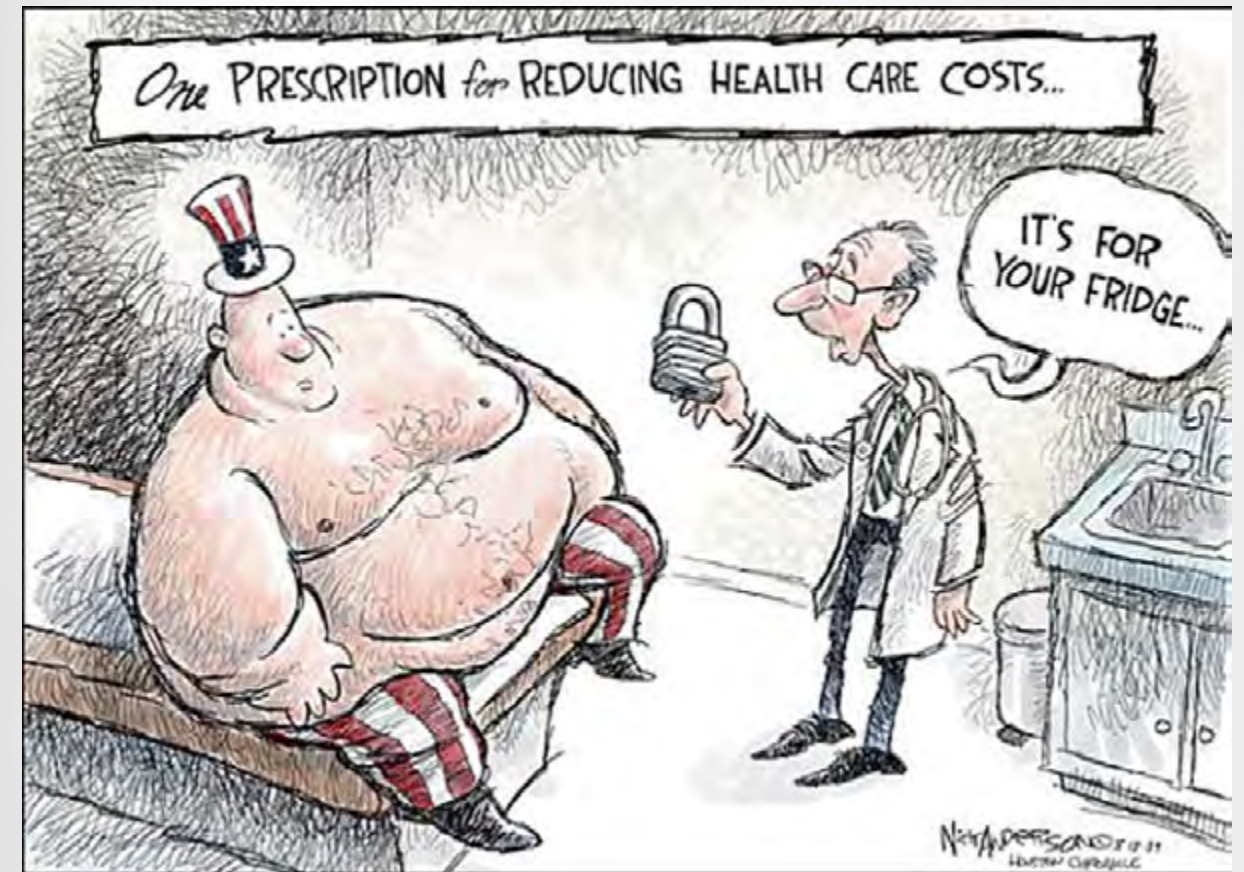

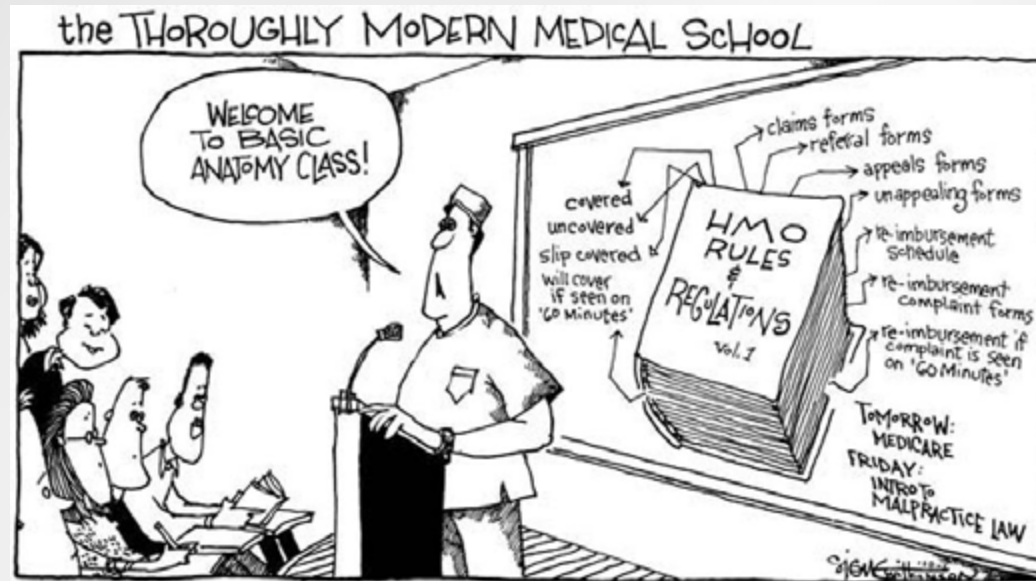

Pig & Pork - Toxic Facts

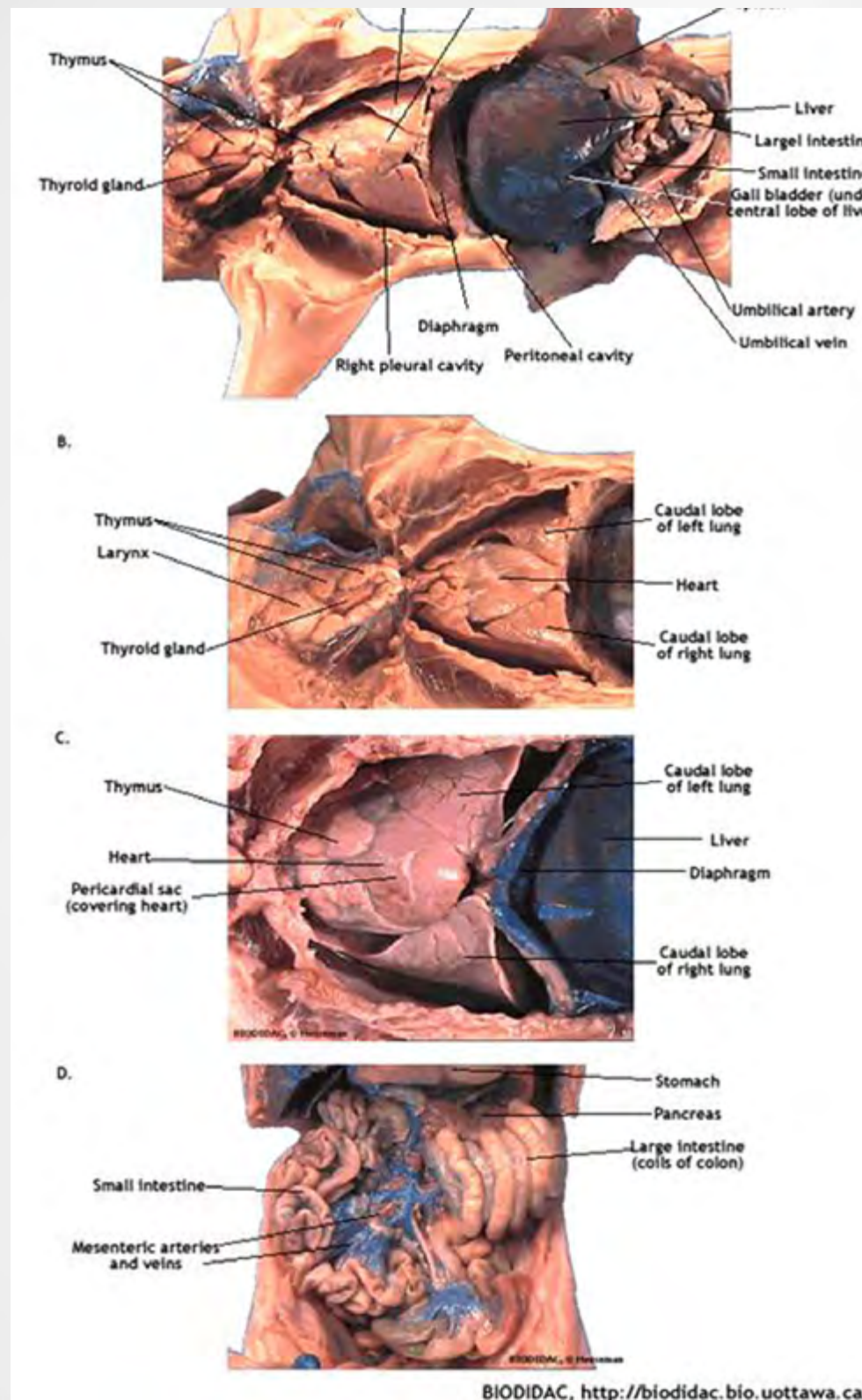

Pig gut and organs

The pig or swine is a very popular food item with most people. Yet Christians are unaware that the God they profess to believe in had condemned the eating of swine's flesh. The condemnation was based on some very sound biological principles. Here are some facts on pork that prove it to be a very unhealthy food to eat:

- A pig is a real garbage gut. It will eat anything including urine, excrement, dirt, decaying animal flesh, maggots, or decaying vegetables. They will even eat the cancerous growths off other pigs or animals.
- The meat and fat of a pig absorbs toxins like a sponge. Their meat can be 30 times more toxic than beef or venison.
- When eating beef or venison, it takes 8 to 9 hours to digest the meat so what little toxins are in the meat are slowly put into our system and can be filtered by the liver. But when pork is eaten, it takes only 4 hours to digest the meat. We thus get a much higher level of toxins within a shorter time.
- Unlike other mammals, a pig does not sweat or perspire. Perspiration is a means by which toxins are removed from the body. Since a pig does not sweat, the toxins remain within its body and in the meat.
- Pigs and swine are so poisonous that you can hardly kill them with strychnine or other poisons.
- Farmers will often pen up pigs within a rattlesnake nest because the pigs will eat the snakes, and if bitten they will not be harmed by the venom.
- When a pig is butchered, worms and insects take to its flesh sooner and faster than to other animal's flesh. In a few days the swine flesh is full of worms.
- Swine and pigs have over a dozen parasites within them, such as tapeworms, flukes, worms, and trichinae. There is no safe temperature at which pork can be cooked to ensure that all these parasites, their cysts, and eggs will be killed.
- Pig meat has twice as much fat as beef and Toxic fat. A 3 oz T bone steak contains 8.5 grams of fat; a 3 oz pork chop contains 18 grams of fat. A 3 oz beef rib has 11.1 grams of fat; a 3 oz pork spare rib has 23.2 grams of fat.
- Cows have a complex digestive system, having four stomachs. It thus takes over 24 hours to digest their vegetarian diet causing its food to be purified of toxins. In contrast, the swine's one stomach takes only about 4 hours to digest its foul diet, turning its toxic food into flesh.
- The swine carries about 30 diseases which can be easily passed to humans. This is why God commanded that we are not even to touch their carcass (Leviticus 11:8).
- The trichinae worm of the swine is microscopically small, and once ingested can lodge itself in our intestines, muscles, spinal cord or the brain. This results in the disease trichinosis. The symptoms are sometimes lacking, but when present they are mistaken for other diseases, such as typhoid, arthritis, rheumatism, gastritis, MS, meningitis, gall bladder trouble, or acute alcoholism.
- The pig is so poisonous and filthy, that nature had to prepare him a sewer line or canal running down each leg with an outlet in the bottom of the foot. Out of this hole oozes pus and filth his body cannot pass into its system fast enough. Some of this pus gets into the meat of the pig.

- There are specific Suine toxins found in pig documented by Dr.Reckeweg as very toxic compounds robbing health from people.

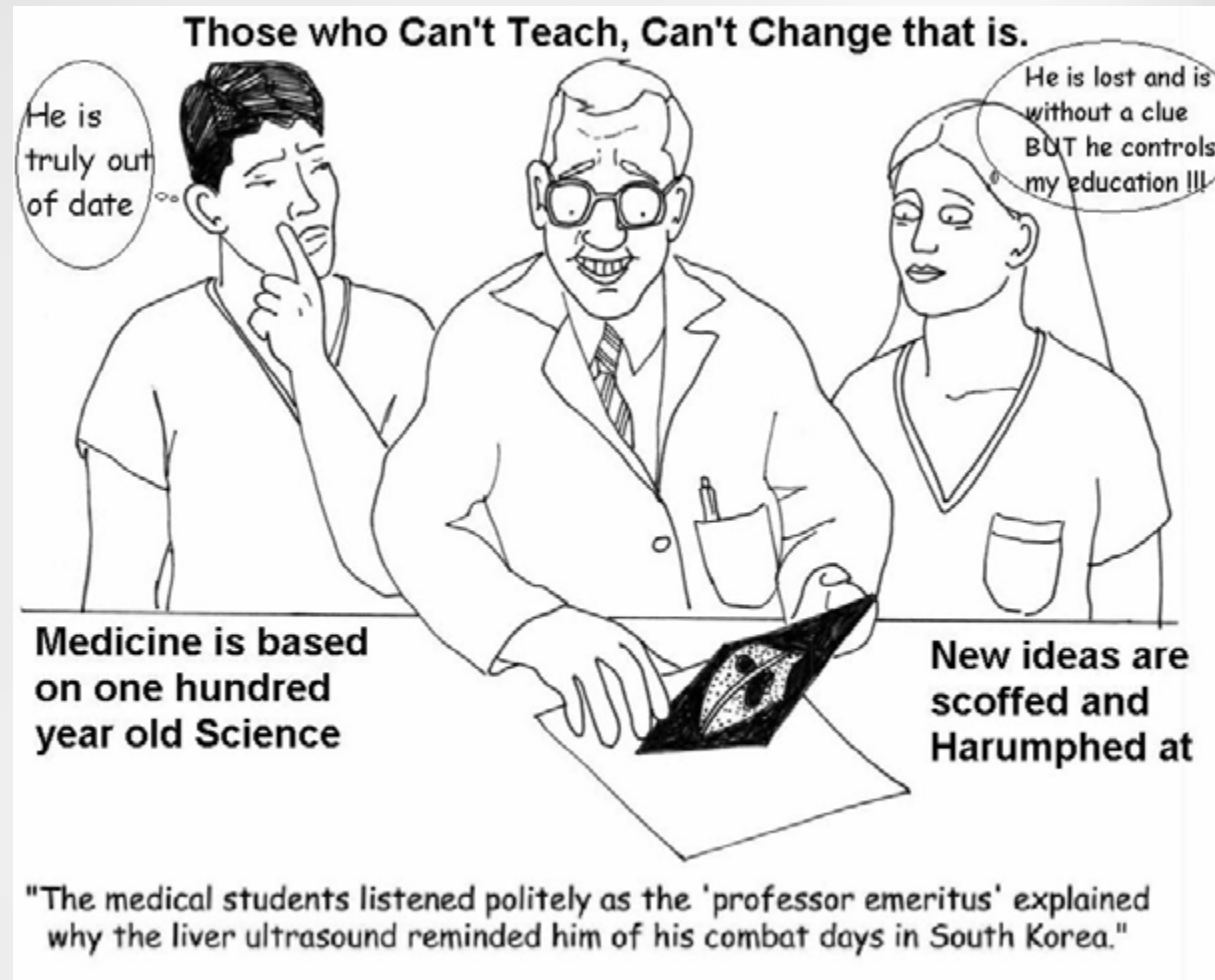

There are other reasons grounded in biological facts that could be listed to show why pigs and swine should not be eaten. But a true Christian should only need one reason why not to eat this type of food because God prohibited it.

"And the swine, because it divides the hoof, yet does not chew the cud, it is unclean unto you: you shall not eat of their flesh, nor touch their dead carcase." - Leviticus 11:7,8; Deuteronomy 14:8

Those who say Christ abolished the law condemning pork are motivated by their stomach not Scripture. The problems with pork are biological, and Christ never changed the laws of biology.

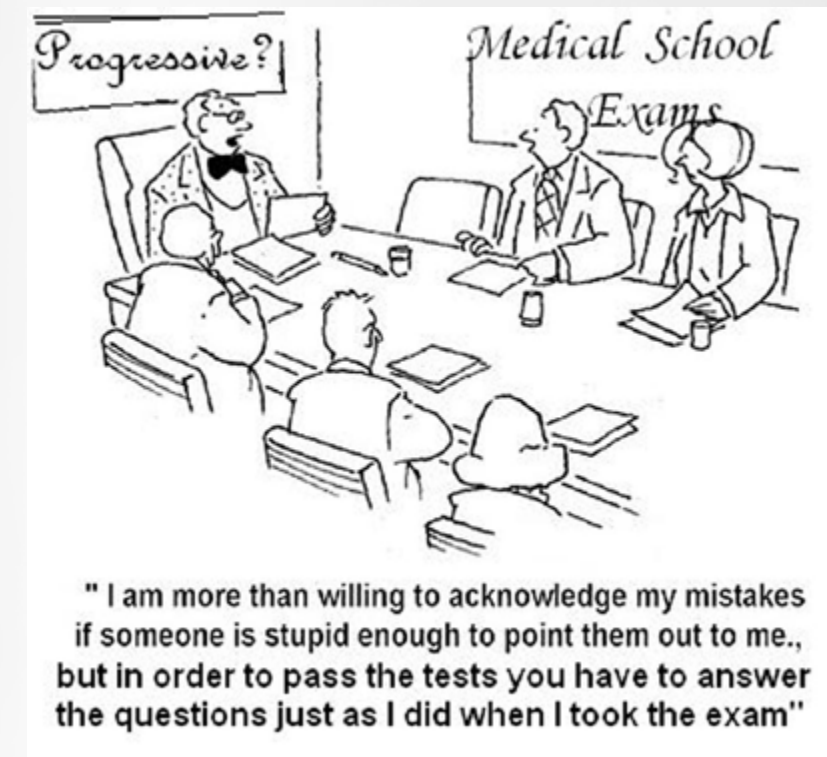

Fungi toxins not detoxified in the Pig Gut

PIGS will eat anything including urine, dirt, decaying animal flesh, maggots, or decaying vegetables and left overs of what people ate. They will even eat the cancerous growths off other pigs or animals. You are killing yourself slowly by eating pig. Pork is like death. The meat and fat of a pig absorbs toxins like a sponge. Their meat can be 50 times more toxic than beef. Pigs don't sweat so the toxins remain within its body and in the meat. And then when a pig is butchered, worms and insects take to its flesh sooner and faster than to other animal's flesh. In a few days the pig flesh is full of worms.

For some people pig is so delicious they must eat it. In the old days we would only eat pig once a year as a celebration usually the fall or winter to celebrate the harvest. Then it became twice a year to celebrate the spring. Then as people became more affluent they started to celebrate monthly then weekly and some daily. If you eat pig very often it will affect your health. Once or twice a year is not so much of a problem if it is well raised pig and well cooked.

Toxins and poisons in your environment. These are things everyone should know about

By Jonathan Elinoff

This list of 13 items was compiled to show others that our environment is not as safe as people hope it to be. What is more disturbing is that every single item listed is man-made and has been known to be harmful since it was injected into our lives. Activists fought against it then, they have since, and they remain fighting against these to this day.

1. DDT



DDT was supposed to be the magic bullet vs. the scourge of insect-borne diseases like malaria. Discovered in 1873, DDT (short for the less catchy dichloro-diphenyl-trichloroethane) wasn't used widely until 1939, when Swiss chemist Paul Hermann Muller noted its effectiveness as a pesticide during World War II, a discovery that earned him a Nobel Prize in 1948. After the war, use exploded: from 1942 to 1972, some 1.35 billion lb. of DDT were used in the U.S.

But absent from the DDT mania was consideration of the environmental effects of dumping millions of pounds of potent pesticides each year. Rachel Carson's seminal 1962 environmental tract *Silent Spring* was the first to call attention to the nasty little fact that DDT produced fertility and neurological problems in humans and accumulated up the food chain in wildlife, poisoning birds. Use of the compound plummeted, and in 1972, DDT was banned in the U.S. entirely.

Effects on human health

Potential mechanisms of DDT on humans are genotoxicity and endocrine disruption. DDT may have direct genotoxicity, but may also induce enzymes that produce other genotoxic intermediates and DNA adducts. It is an endocrine disruptor; The DDT metabolite DDE acts as an antiandrogen (but not as an estrogen). *o,p'*-DDT, a minor component in commercial DDT has weak estrogenic activity.

Acute toxicity

DDT is classified as "moderately toxic" by the United States National Toxicology Program (NTP) and "moderately hazardous" by WHO, based on the rat oral of 113 mg/kg. DDT has on rare occasions been administered orally as a treatment for barbiturate poisoning.

Chronic toxicity

Diabetes

Organochlorine compounds, generally, and DDT and DDE, specifically, have been linked to diabetes. A number of studies from the US, Canada, and Sweden have found that the prevalence of the disease in a population increases with serum DDT or DDE levels.

Developmental and reproductive toxicity

DDT and DDE, like other organochlorines, have been shown to have xenoestrogenic activity, meaning they are chemically similar enough to estrogens to trigger hormonal responses in animals. This endocrine disrupting activity has been observed toxicological studies involving mice and rats, and available epidemiological evidence indicates that these effects may be occurring in humans as a result of DDT exposure. There is therefore concern that DDT may cause developmental and reproductive toxicity.

Other

Occupational exposure to DDT (either as a farmer or a malaria control worker) has been linked to:

- Neurological problems
- Asthma

Carcinogenicity

DDT is suspected to cause cancer. The NTP classifies it as "reasonably anticipated to be a human carcinogen", and the EPA classifies DDT, DDE, and DDD as a class B2 "probable" human carcinogens. The International Agency for Research on Cancer classifies it as a "possible" human carcinogen. These evaluations are based mainly on the results of animal studies.

There is epidemiological evidence (i.e. studies in humans) that DDT causes cancer of the liver, pancreas and breast. There is mixed evidence that it contributes to leukemia, lymphoma and testicular cancer.

Breast cancer

The question of whether DDT or DDE are risk factors of breast cancer has been the subject of numerous investigations. While individual studies have come to conflicting conclusions, the most recent reviews of all the evidence conclude that exposure to DDT before puberty increases the risk of breast cancer later in life. Until recently, almost all studies measured DDT or DDE blood levels at the time of breast cancer diagnosis or after. This study design has been criticized, since the levels of DDT or DDE at diagnosis do not necessarily correspond to the levels present in a woman's body at the time when her cancer first started. Such studies have thus yielded conflicting results and taken as a whole "do not support the hypothesis that exposure to DDT is an important risk factor for breast cancer." The studies of this design have been extensively reviewed.

2. Leaded Gasoline



Pull in to the local gas station and every pump has something in common. "Unleaded" is the new craze. For nearly six decades, gasoline companies ignored the known dangers associated with lead to get rich. Tetraethyl lead boosted the octane levels in auto fuel, but there was speculation surrounding the safety of that decision from Day One. In the Nov. 10, 1924, issue of TIME, a report showed that 35 men at the Standard Oil Company of New Jersey had come down with an "occupational disease." Symptoms ranged from insomnia to low blood pressure, all at the hands of lead poisoning. The EPA completed a full phaseout of lead gasoline in 1986, ending the quest to trade steady health for steady sales.

Qualms about leaded gasoline began with the environmentalists and health professionals. Apparently, leaded gasoline was incompatible with catalytic converters installed in many on-road vehicles being driven. Catalytic converters are devices used to reduce the toxicity levels of automobile emissions. They are, however, ineffective in the presence of lead due to a chemical alteration that results from their interaction. The Environmental Protection Agency (EPA) stepped in quickly to regulate amounts of auto exhaust, leading to the general disapproval of leaded gasoline use.

Moreover, health professionals determined that consumption of lead products, including leaded gasoline, correlated with the amount of lead found in the human bloodstream. This can cause lead

poisoning, a condition that primarily causes neurological damage, gastrointestinal discomfort, and cognitive impairment in children.

3. Lead Paint



Lead paint or lead based paint (LBP) is paint containing lead, a heavy metal, that is used as pigment, with lead(II) chromate and lead(II) carbonate being the most common. Lead is also added to paint to speed drying, increase durability, retain a fresh appearance, and resist moisture that causes corrosion. In some countries lead continues to be added to paint intended for domestic use whereas in others regulation exists that prohibits this, though lead paint may still be found in older properties painted prior to the introduction of such regulation e.g. in the U.S. and the U.K. and Australia. Paint with significant lead content is still used in industry and by the military. For example, leaded paint is sometimes used to paint roadways and parking lot lines.

Although lead improves paint performance, it is a dangerous substance. It is especially damaging to children under age six whose bodies are still developing. Lead causes nervous system damage, stunted growth, and delayed development. It can cause kidney damage and affects every organ system of the body. It also is dangerous to adults, and can cause reproductive problems for both men and women.

One myth related to lead-based paint is that the most common cause of poisoning was eating leaded paint chips. In fact, the most common pathway of childhood lead exposure is through ingestion of lead dust through normal hand-to-mouth contact during which children swallow lead

dust dislodged from deteriorated paint or leaded dust generated during remodeling or painting. Lead dust from remodeling or deteriorated paint lands on the floor near where children play and can be ingested.

4. Asbestos

SIX-PHASE TABLE						
	MINERAL PHASES		MAYITE PHASES		CELLULOSE PHASES	
Organ System	Asbestos Phase	Amphibole Phase	Serpentine Phase	Amphibole Phase	Serpentine Phase	Amphibole Phase
Eye	Opacities of cornea	None	None	None	None	None
Nervous System	Cellular degeneration	None	Central lesions	None	None	None
Respiratory System	None	Asbestosis, pleural plaques	None	None	None	None
Cardiovascular System	None	None	None	None	None	None
Reproductive System	None	None	None	None	None	None
Immune System	None	None	None	None	None	None
Other	None	None	None	None	None	None

At first glance, asbestos appears to be a construction worker's confidant. It is a versatile mineral fiber that excels at absorption and can withstand the harshness of heat. But when floor tiles or roof shingles need to be repaired or replaced, asbestos morphs into a homeowner's headache. Those same strong fibers that drive a building's start can turn nasty during remodeling or demolition stages. Inhaling the toxic particles in that state causes asbestosis — a condition instigated by fibrosis in the lungs, sparking chest pain, shortness of breath, nail abnormalities, clubbing of fingers and other complications. With those factors in mind, the EPA issued a ruling on July 12, 1989, banning most asbestos-containing products. But two years later, the Fifth Circuit Court of Appeals in New Orleans overturned that decision, leaving only some products on the banned list: flooring felt, rollboard and corrugated, commercial and specialty paper. When a substance makes its way into the federal government's Agency for Toxic Substances & Disease Registry, something was wrong to begin with.

Chrysotile asbestos, like all other forms of asbestos, has produced tumors in animals. Mesotheliomas have been observed in people who were occupationally exposed to chrysotile, family members of the occupationally exposed, and residents who lived close to asbestos factories and mines. Amosite and crocidolite are the most hazardous of the asbestos minerals because of their long

persistence in the lungs of exposed people. Tremolite often contaminates chrysotile asbestos, thus creating an additional hazard.

Asbestos exposure becomes a health concern when high concentrations of asbestos fibers are inhaled over a long time period. People who become ill from inhaling asbestos are often those who are exposed on a day-to-day basis in a job where they worked directly with the material.

As a person's exposure to fibers increases, because of being exposed to higher concentrations of fibers and/or by being exposed for a longer time, then that person's risk of disease also increases. Disease is very unlikely to result from a single, high-level exposure, or from a short period of exposure to lower levels. Smoking combined with asbestos exposure may increase the health risk dramatically.

Other asbestos-related diseases

Asbestos warts: caused when the sharp fibers lodge in the skin and are overgrown causing benign callus-like growths.

Pleural plaques: discrete fibrous or partially calcified thickened area which can be seen on X-rays of individuals exposed to asbestos. Although pleural plaques are themselves asymptomatic, in some patients this develops into pleural thickening.

Diffuse pleural thickening: similar to above and can sometimes be associated with asbestosis. Usually no symptoms shown but if exposure is extensive, it can cause lung impairment.

5. Olestra



When it comes to nutrition, what better equation could there be than zero calories, zero grams of

cholesterol and zero grams of fat? In January 1996, the FDA approved olestra as a food additive. Cut out the unhealthy cooking oil. Shred the package of shortening. Bury the stick of butter. Frito-Lay was among the first companies to jump on board, introducing its WOW! division of potato chips in 1998 to claim fat-free stomach satisfaction. But olestra proved to be a greedy chemical. It not only removed unwanted fat from foods but also negated the body's ability to absorb essential vitamins. Side effects included cramps, gas and loose bowels, turning fat-free French fries into a foiled business fad. The FDA has kept olestra as a legal food additive to this day, though, leaving its health implications in the hands of individual consumers.

Olestra (also known by its brand name Olean) is a fat substitute that adds no fat, calories, or cholesterol to products. It has been used in the preparation of traditionally high-fat foods such as potato chips, thereby lowering or eliminating their fat content.

Olestra was approved by the Food and Drug Administration for use as a food additive in 1996 and was initially used in potato chips under the WOW brand by Frito Lay. In 1998, which was the first year Olestra products were marketed nationally after the FDA's Food Advisory Committee confirmed a judgment it made 2 years earlier, sales were over \$400 million. However, by 2000 sales slowed to \$200 million, largely caused by the unappealing side effects described on the FDA-mandated health warning label "This Product Contains Olestra. Olestra may cause abdominal cramping and loose stools. Olestra inhibits the absorption of some vitamins and other nutrients. Vitamins A, D, E, and K have been added."

This condition (normally occurring only by excessive consumption in a short period of time) led to a condition known as "steatorrhea", which can be embarrassing. Sales were so slow that P&G gave up on attempts to widen the uses of Olestra, and even sold off their Cincinnati-based Olestra factory to Twin Rivers Technologies in February 2002.

The FDA removed the warning requirement in 2003 as it had "conducted a scientific review of several post-market studies submitted by P&G, as well as adverse event reports submitted by P&G and the Center for Science in the Public Interest (a particularly outspoken critic). The FDA concluded that the label statement was no longer warranted", in spite of having received over 20,000 complaints. When removing the Olestra warning label, the FDA cited a 6-week Procter & Gamble (makers of Olestra) study of more than 3000 people showing that an Olestra-eating group experienced only a small increase in bowel movement frequency.

P&G also worked hard in its publicity campaigns to highlight the positives of the additive, even working directly with the health-care community. But, outside of the popular culture disapproval of the product, many consumers simply did not see the speedy results for which they had hoped from a product they saw as being a cure-all. This was because Olestra only addressed the fat component of the overall dietary pattern of Americans. Foods containing olestra do not contain calories from fats and many Americans believed that they could just eat more of them to compensate for the fat calories "saved". Eating olestra chips was not a particularly effective way to improve one's diet overall.

Olestra is banned in many countries, including the United Kingdom and Canada

6. Fluoride (Water Fluoridation)



"In summary, we hold that fluoridation is an unreasonable risk." - US ENVIRONMENTAL PROTECTION AGENCY HEADQUARTERS' UNION, 2001.

"Over the past ten years a large body of peer-reviewed science has raised concerns that fluoride may present unreasonable health risks, particularly among children, at levels routinely added to tap water in American cities." - ENVIRONMENTAL WORKING GROUP, July 2005

"I am quite convinced that water fluoridation, in a not-too-distant future, will be consigned to medical history." - Dr. ARVID CARLSSON, Winner, Nobel Prize for Medicine (2000).

Water fluoridation is the controlled addition of fluoride to a public water supply to allegedly reduce tooth decay. Fluoridated water has fluoride at a level that is effective for preventing cavities; this can occur naturally or by adding fluoride. Fluoridated water operates on tooth surfaces: in the mouth it creates low levels of fluoride in saliva, which reduces the rate at which tooth enamel demineralizes and increases the rate at which it remineralizes in the early stages of cavities. Typically a fluoridated compound is added to drinking water, a process that in the U.S. costs an average of about \$0.94 per person-year. Defluoridation is needed when the naturally occurring fluoride level exceeds recommended limits. A 1994 World Health Organization expert committee suggested a level of fluoride from 0.5 to 1.0 mg/L (milligrams per liter), depending on climate. Bottled water typically has unknown fluoride levels, and some domestic water filters remove some or all fluoride

7. Agent Orange



Presently the Veterans Administration provides compensation and treatment for several diseases to former military service personnel who were exposed to Agent Orange



A potent herbicide used from 1961 to 1971 in the Vietnam War, Agent Orange was designed to cut through Vietnam's thick canopy of foliage to reveal enemy troops beneath. While it succeeded, the price was high: exposure proved deadly to humans, causing cancers, birth defects and a slew of other disorders. Some 21 million gallons of it were dumped on Vietnam, resulting in hundreds of thousands of injuries and birth defects to Vietnamese citizens. U.S. veterans faced exposure too; they received a \$180 million settlement from its manufacturers in 1984.

According to Vietnamese Ministry of Foreign Affairs, 4.8 million Vietnamese people were exposed to Agent Orange, resulting in 400,000 deaths and disabilities, and 500,000 children born with birth defects. The most affected zones are the mountainous area along Truong Son (Long Mountains) and the border between Vietnam and Cambodia. The affected residents are living in sub-standard conditions with many genetic diseases.

The use of Agent Orange still has an effect on the citizens of Vietnam, poisoning their food chain and creating concern about its effect on human beings. This chemical has been reported to cause serious skin diseases as well as a vast variety of cancers in the lungs, larynx, and prostate. Children in the areas where Agent Orange was used have been affected and have multiple health problems including cleft palate, mental disabilities, hernias, and extra fingers and toes.

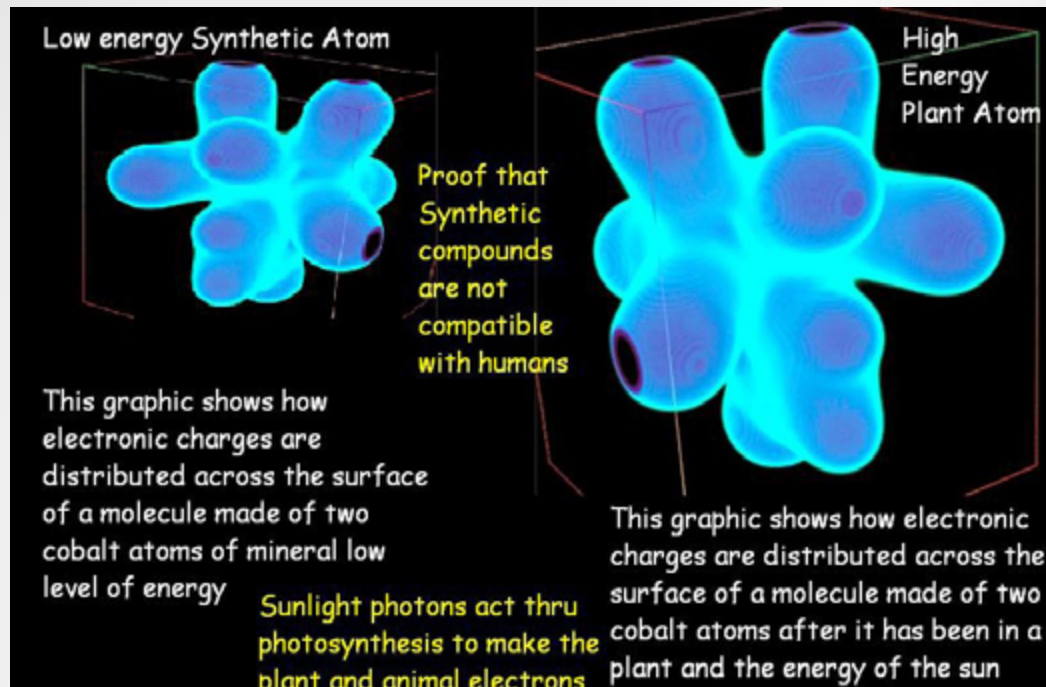

8. Depleted Uranium



Depleted uranium (DU) is uranium primarily composed of the isotope uranium-238 (U-238). Natural uranium is about 99.27 percent U-238, 0.72 percent U-235, and 0.0055 percent U-234. U-235 is used for fission in nuclear reactors and nuclear weapons.

DU is useful because of its very high density of 19.1 g/cm. Civilian uses include counterweights in aircraft, radiation shielding in medical radiation therapy and industrial radiography equipment, and containers used to transport radioactive materials. Military uses include defensive armor plating and armor-piercing projectiles.

The use of DU in munitions is controversial because of questions about potential long-term health effects. Normal functioning of the kidney, brain, liver, heart, and numerous other systems can be affected by uranium exposure, because in addition to being weakly radioactive, uranium is a toxic metal. It is weakly radioactive and remains so because of its long physical half-life (4.468 billion years for uranium-238), but has a considerably shorter biological half-life. The aerosol produced during impact and combustion of depleted uranium munitions can potentially contaminate wide areas around the impact sites or can be inhaled by civilians and military personnel. During a three week period of conflict in 2003 in Iraq, 1,000 to 2,000 tons of DU munitions were used, mostly in cities.



9. CFCs

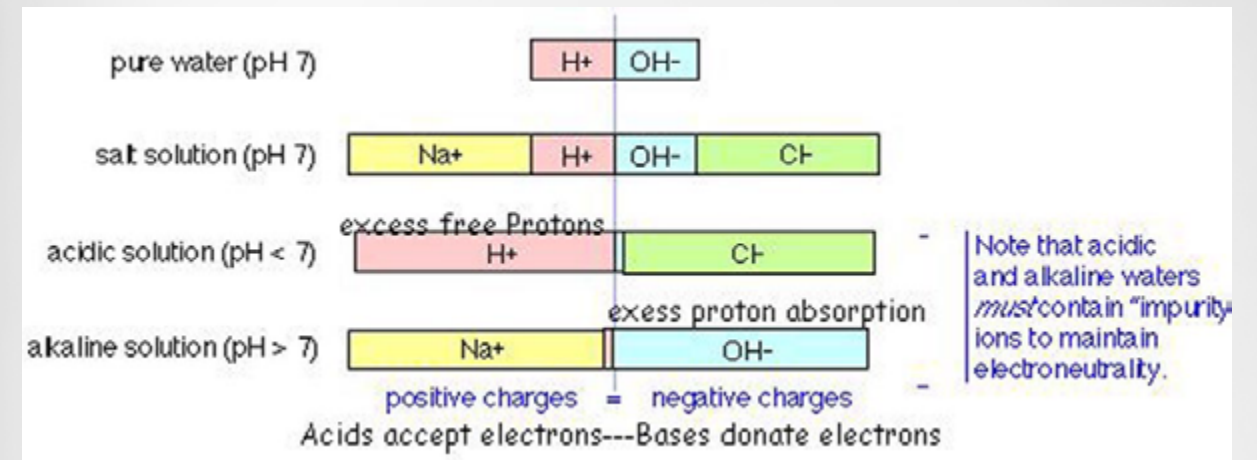

Short for chlorofluorocarbons, CFCs are nasty chemical compounds that wreak havoc on the environment. Used in refrigeration units and aerosol cans, CFCs combine with atmospheric ozone, neutralizing the molecular compound and weakening the ozone layer, an important environmental barrier that protects the earth's surface from ultraviolet radiation from the sun. While increased regulation since the 1970s has diminished their use, CFCs can endure in the atmosphere for nearly a century, making this a very long-lived mistake.

According to their Material Safety Data Sheets, CFCs and HCFCs are colourless, volatile, relatively non-toxic liquids and gases with a faintly sweet ethereal odour. Overexposure may cause dizziness, loss of concentration, Central Nervous System depression and/or cardiac arrhythmia. Vapors displace air and can cause asphyxiation in confined spaces. Although non-flammable, their combustion products include hydrofluoric acid, phosgene, and related species.

10. Plastic Grocery Bags



Touted as a convenient and cheap alternative to paper bags, plastic grocery bags gained acceptance in the late 1970s and now meet 80% of retailers' bagging needs. They've saved millions of trees but come with equally bad consequences: more than 500 million are used and discarded each year, millions of which never make it to a landfill and fall as litter. And depending on the plastic used in production, those bags may take several hundred years to decompose. The solution? Recycle, or better yet, skip both paper and plastic and bring a reusable bag of your own.

11. Cigarettes



The earliest forms of cigarettes have been attested in Central America around the 9th century in the form of reeds and smoking tubes. The Maya, and later the Aztecs, smoked tobacco and

various psychoactive drugs in religious rituals and frequently depicted priests and deities smoking on pottery and temple engravings. The cigarette, and the cigar, were the most common method of smoking in the Caribbean, Mexico and Central and South America until recent times.

The South and Central American cigarette used various plant wrappers; when it was brought back to Spain, maize wrappers were introduced, and by the seventeenth century, fine paper. The resulting product was called *papelate* and is documented in Goya's paintings *La Cometa*, *La Merienda en el Manzanares*, and *El juego de la pelota a pala* (18th century).

Nicotine, the primary psychoactive chemical in cigarettes, is addictive. Cigarette use by pregnant women has also been shown to cause birth defects (which include mental and physical disability). On average, each cigarette smoked shortens lifespan by 11 minutes and half of smokers die early of tobacco-related disease and lose, on average, 14 years of life.

The list of 599 additives approved by the US Government for use in the manufacture of cigarettes is something every smoker should see. Submitted by the five major American cigarette companies to the Dept. of Health and Human Services in April of 1994, this list of ingredients had long been kept a secret.

Tobacco companies reporting this information were:

- American Tobacco Company
- Brown and Williamson
- Liggett Group, Inc.
- Philip Morris Inc.
- R.J. Reynolds Tobacco Company

While these ingredients are approved as additives for foods, they were not tested by burning them, and it is the burning of many of these substances which changes their properties, often for the worse. Over 4000 chemical compounds are created by burning a cigarette, many of which are toxic and/or carcinogenic. Carbon monoxide, nitrogen oxides, hydrogen cyanide and ammonia are all present in cigarette smoke. Forty-three known carcinogens are in mainstream smoke, sidestream smoke, or both.

It's chilling to think about not only how smokers poison themselves, but what others are exposed to by breathing in the secondhand smoke. The next time you're missing your old buddy, the cigarette, take a good long look at this list and see them for what they are: a delivery system for toxic chemicals and carcinogens.

Cigarettes offer people only a multitude of smoking-related diseases and ultimately death.

The List of 599 Additives in Cigarettes is primarily:

- Acetanisole
- Acetic Acid
- Acetoin
- Acetophenone
- 6-Acetoxydihydrotheaspirane

- 2-Acetyl-3- Ethylpyrazine
- 2-Acetyl-5-Methylfuran
- Acetylpyrazine
- 2-Acetylpyridine
- 3-Acetylpyridine
- 2-Acetylthiazole
- Aconitic Acid
- dl-Alanine
- Alfalfa Extract
- Allspice Extract, Oleoresin, and Oil
- Allyl Hexanoate
- Allyl Ionone
- Almond Bitter Oil
- Ambergris Tincture
- Ammonia
- Ammonium Bicarbonate
- Ammonium Hydroxide
- Ammonium Phosphate Dibasic
- Ammonium Sulfide
- Amyl Alcohol
- Amyl Butyrate

12. Aspartame



Aspartame (or **APM**) is the name for an artificial, non-saccharide sweetener used as a sugar substitute in many foods and beverages. In the European Union, it is known under the E number (additive code) E951. Aspartame is the methyl ester of a phenylalanine/aspartic acid dipeptide.

Aspartame was first synthesized in 1965. Its use in food products was first approved by the United States Food and Drug Administration in 1974. Because its breakdown products include phenylalanine, aspartame is among the many substances that must be avoided by people with phenylketonuria (PKU), a rare genetic condition.

The safety of aspartame has been the subject of several political and medical controversies, Congressional Hearings and internet hoaxes since its initial approval by the U.S. Food and Drug Administration (FDA) in 1974.

You need to read your labels, these may well be in more products than you suspect. If you take vitamins, remember to check those as well. Check anything that is consumable!

- Aspartame
- Acesulfame-k
- Low Calorie
- Low Sugar
- No Calories
- Saccharin
- Sugar Free

The following is a brief list, compiled by the author, of products containing the artificial sweetener Aspartame. This list will be periodically updated and user submissions are welcomed, just leave a comment, these will be added to the list then when verified.

Product Name	Category
Diet Coca Cola (all varieties) Coca Cola Zero (all varieties) Diet Pepsi (all varieties) Pepsi Max (all varieties) Diet Irn Bru (all varieties) Lilt Zero (all varieties) Sprite Zero (all varieties) Tango (all varieties) Tango no added sugar (all varieties) 7up Free (all varieties) Lucozade Sport (all varieties) Schweppes Slimline Drinks (all varieties) Fanta Zero (all varieties) Fanta Orange Dr Pepper Zero Oasis Summer Fruits Extra Light Oasis Citrus Punch	Soft Drink
Ribena Really light (all varieties) Robinsons Orange Squash Robinson's No added sugar range	Cordial
Muller Light Cherry Muller Light Blueberry Muller Light Raspberry Muller Light Banana and Custard Danone Activia Cherry Weight Watchers Fromage Frais Weight Watchers Toffee and Vanilla	Yoghurt

Product Name	Category
Wrigleys Airwaves (all varieties) Wrigleys Orbit (all varieties) Wrigleys Extra (all varieties)	Chewing Gum
Uncle Ben's Sweet and Sour Light	Cooking Sauce
Walkers Sensations Sweet Thai Chilli Walkers Sensations Lime and Thai Spices Walkers Prawn Cocktail	Crisps
Canderel Silver Spoon Sweetness and Light Silver Spoon Light Granulated Sugar	Tabletop Sweeteners
Cadburys Highlights (all varieties) Options Hot Chocolate Drink (all varieties)	Drink powders

13. PCB's



Polychlorinated biphenyls (PCBs) are a class of organic compounds with 1 to 10 chlorine atoms attached to biphenyl, which is a molecule composed of two benzene rings. PCBs were widely used for many applications, especially as dielectric fluids in transformers, capacitors, and coolants. Due to PCB's toxicity and classification as a persistent organic pollutant, PCB production was banned by the United States Congress in 1979 and by the Stockholm Convention on Persistent Organic Pollutants in 2001.

Alternative names

Commercial PCB mixtures were marketed under the following names.:

Brazil	Ascarel
Former Czechoslovakia	Delor
France	Phenoclor Pyraléne (both used by Prodelec)
Germany	Clophen (used by Bayer)
Italy	

History

PCBs, originally termed "chlorinated diphenyls," were commercially produced as complex mixtures containing multiple isomers at different degrees of chlorination. In the United States, commercial production of PCBs was taken over in 1929 by Monsanto Company from Swann Chemical Company. Manufacturing levels increased in response to the electrical industry's need for a "safer" (than flammable mineral oil) cooling and insulating fluid for industrial transformers and capacitors. PCBs were also commonly used as stabilizing additives in the manufacture of flexible PVC coatings for electrical wiring and electronic components to enhance the heat and fire resistance of the PVC.

The toxicity associated with PCBs and other chlorinated hydrocarbons, including polychlorinated naphthalenes was recognized very early due to a variety of industrial incidents. A conference about the hazards was organized at Harvard School of Public Health in 1937, and a number of publications referring to the toxicity of various chlorinated hydrocarbons were published before 1940. Robert Brown reminded chemists in 1947 that Arochlors were "objectionably toxic. Thus the maximum permissible concentration for an 8-hr. day is 1 mg/m³ of air. They also produce a serious and disfiguring dermatitis". However, PCB manufacture and use continued with few restraints until the 1970s.

PCBs are persistent organic pollutants and have entered the environment through both use and disposal. The environmental transport of PCBs is complex and nearly global in scale. The public, legal, and scientific concerns about PCBs arose from research indicating they were likely carcinogens having the potential to adversely impact the environment and therefore undesirable as commercial products. Despite active research spanning five decades, extensive regulatory actions, and an effective ban on their production since the 1970s, PCBs still persist in the environment and remain a focus of attention.

The only North American producer, Monsanto Company, marketed PCBs under the trade name Aroclor from 1930 to 1977. These were sold under trade names followed by a 4 digit number. The

first two digits generally refer to the number of carbon atoms in the biphenyl skeleton (for PCBs this is 12), the second two numbers indicate the percentage of chlorine by mass in the mixture. Thus, Aroclor 1260 has 12 carbon atoms and contains 60% chlorine by mass. An exception is Aroclor 1016, which also has 12 carbon atoms, but has 42% chlorine by mass. Different Arochlors were used at different times and for different applications. In electrical equipment manufacturing in the USA, Aroclor 1260 and Aroclor 1254 were the main mixtures used before 1950, Aroclor 1242 was the main mixture used in the 1950s and 1960s until it was phased out in 1971 and replaced by Aroclor 1016.

Manufacture peaked in the 1960s, by which time the electrical industry had lobbied the U.S. Congress to make them mandatory safety equipment. In 1966, they were determined by Swedish chemist Dr. Soren Jensen to be an environmental contaminant, and it was Dr. Jensen, according to a 1994 article in Sierra, who named them PCBs. Previously, they had simply been called "phenols" or referred to by various trade names, such as Aroclor, Kennechlor, Pyrenol, Chlorinol and others. Their commercial utility was based largely on their chemical stability, including low flammability, and desirable physical properties, including electrical insulating properties. Their chemical and physical stability is responsible for their continuing persistence in the environment, and the lingering interest decades after regulations were imposed to control environmental contamination.

In 1972, PCB production plants existed in Austria, the then Federal Republic of Germany, France, Great Britain, Italy, Japan, Spain, USSR, and USA.

In 1973 the use of PCBs was banned in "open" or "dissipative" sources, such as:

- plasticisers in paints and cements
- casting agents
- fire retardant fabric treatments and heat stabilizing additives for PVC electrical insulation
- adhesives
- paints and water-proofing
- railway sleepers

However, they continued to be allowed in "totally enclosed uses" such as transformers and capacitors, which, in certain failure modes or out-of-specification conditions, can leak, catch fire, or explode. It was Ward B. Stone of the New York State Department of Environmental Conservation (NYSDEC) who first published his findings in the early 1970s that PCBs were leaking from transformers and had contaminated the soil at the bottom of utility poles. [citation needed] Concern over the toxicity and persistence (chemical stability) of PCBs in the environment led the United States Congress to ban their domestic production in 1979, although some use continues in closed systems such as capacitors and transformers.

"Enclosed uses" of PCBs include:

- capacitors
- insulating fluids in transformers
- vacuum pump fluids
- hydraulic fluids

In the UK, closed uses of PCBs in new equipment were banned in 1981, when nearly all UK PCB synthesis ceased, but closed uses in existing equipment containing in excess of 5 litres of PCBs were not stopped until December 2000.

In Japan, PCBs were first produced by Kanegafuchi Chemical Co. Ltd. (Kaneka) in 1954 and production continued until 1972 when the Japanese government banned the production, use, and import of PCBs.

Estimates have put the total global production of PCBs on the order of 1.5 million tons. The United States was the single largest producer with over 600,000 tons produced between 1930 and 1977. The European region follows with nearly 450,000 tons through 1984. It is unlikely that a full inventory of global PCB production will ever be accurately tallied, as there were factories in Poland, East Germany, and Austria that produced unknown amounts of PCBs.

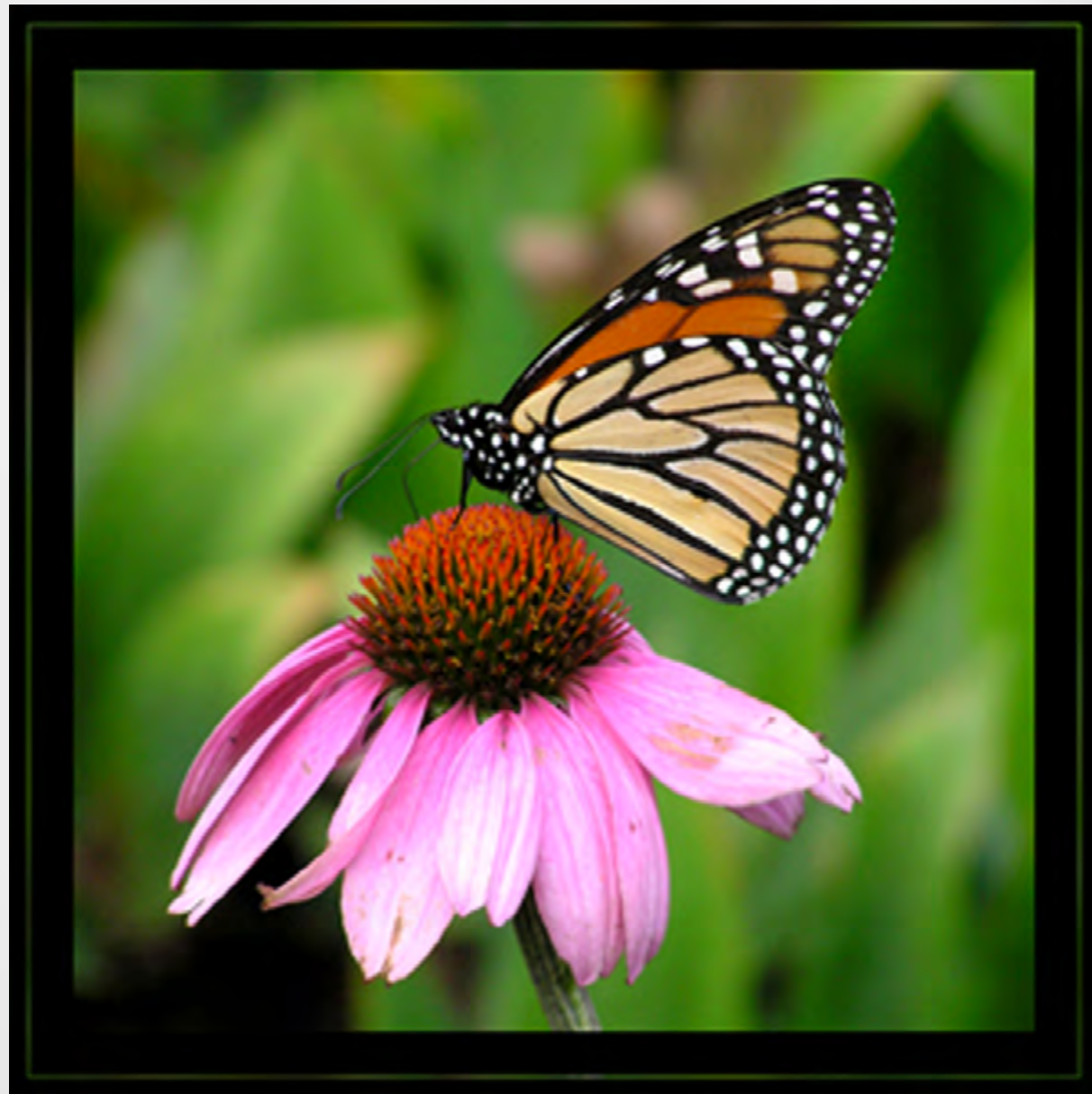

the books **3D Views on Natural Cancer Therapies**

**Immune Stimulation
The True Health Care Debate**

Years ago I was excited to see some infomercials about alternative medicine treatments for diseases. The speaker talked a good show and sold me to buy his books. But there was absolutely no real advice in the books, only multilevel companies with more to buy. This made me angry and then I decided to write the best self help books on natural medicine. Editing and collecting the best in real substantiated advice.

Desiré has written two incredible books and made movies to go with them. What to do for influenza and specifically what to do when the next major virus hits. A movie and a self help book designed to really help you and your families understand what to do to protect yourself.

Also cancer is such a devastating disease, and there are ways to help yourself in the kitchen with cooking for cancer patients. Full advice from soup to nuts on exercise, mediation, cooking, and more. Coupled with a video for the science of how it works.

The health care debate is bringing a question of health and care. In this incredible new book Desiré has outlined a very thorough review of the real problems of Health Care. This book will tell you the truth the chemical companies do not want you to hear.



If you need more information on the SCIO and purchase details please get in touch with us

Maitreya Kft.

tel: +3613036043 | web: www.qxsubspace.com | e-mail: info@qxsubspace.com

3D Views on Natural Cancer Therapies



Immune Stimulation



The True Health Care Debate

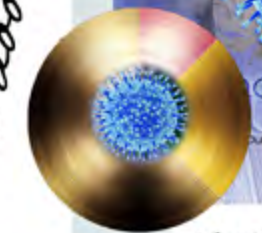

Homotoxicology and Pathology

HOMOTOXICOLOGY

The body must deal with detox. We must exhale to inhale. We must urinate and defecate. Our skin must sweat and our mucous membranes detox as well. We must cleanse before we nourish. There is a simple fact of biology that no organism can survive in his own waste. Because of this we have been given an instinct to dislike our waste products. These have become some of our swear or taboo words, such as shit, piss, or snot. We scold our children when they discuss these.

As we are exposed to more and more toxins our detox mechanisms of the body are overloaded. This can often produce an excess toxic release. Such as diarrhea, excess sweat, smelly urine, skin conditions, etc. Since we have an instinct to dislike these auto toxins we often see them as symptoms. If we are so unlucky or unwise to then see an allopath, then the allopath will most often fight the symptom, by prescribing a drug that blocks the detox response. Antihistamines block the detox of our sinus, Antipyretics stop the detox of our fevers, Antispasmodics stop the intestinal cleanse, and on and on. The worst drugs are the steroids such as the cortisone creams that stop the skin detox and drive the toxins in deeper. Steroids are the best compounds for fighting detox symptoms.

The German field of homotoxicology shows us how these toxins can build up and start to be deposited into other tissues and eventually cause cancer. The chart on Homotoxicology outlines the process. At the top there are the stages of detox, and down the side we have the tissue types where the toxins can have effects. A field of detoxifying homeopathy has arisen from this observation. By using certain toxins homeopathically we can stimulate detox and correct the allopathic damage. This allows for us to deal with the underlying disease and then clear up the symptoms naturally. The symptoms are just signposts of deeper pathology.

If we use organic toxins we call them nosodes. Nosodes are diseased or disease-causing tissue. If we use synthetic man-made compounds we call them isodes or detoxtosodes. Often times a synthetic compound entered into the body is dealt with inappropriately by the liver. The liver makes proteins to bind to the toxins and disable them. If the liver makes an inappropriate protein a new toxin can result. This is called a prion. Prion homeopathics can also help us in treating exposed patients. This allows us to develop a refined arsenal of homeopathic medications for the illnesses of the world.

The use of nosodes, isodes, allersodes, and sarcodes is an ever increasingly popular form of homeopathy around the world. It is gaining in medical popularity daily. This art needs to be responsive to an ever-changing world. As new viruses are developing and genetic variance is continuously changing the entire microorganism field, only a flexible model for development of homeopathics can allow us to respond to new health crises. There are new synthetic compounds developed daily around the world as well. Many homeopaths and government regulators seek to limit the responsiveness of homeopathy. Many homeopaths want to limit homeopathy to only the basic substances used by classic homeopaths. This could rob our society of a powerful tool in correcting new diseases and new disease pictures. Please do what you can to stop the limiting of homeopathy.

INFLAMMATION

The inflammation or symptom is almost always the body trying to heal itself. Fighting the symptom is like shooting the messenger. The next diagram shows the reaction to allopathic treatment.

Subduing inflammation, fever, swelling, etc. too early, without a chance to do its job, can have serious effects on the patient as it robs the patient of his ability to detox and lets toxins build up to cause problems later. Inflammation is not always our enemy; often it is our friend.

The fallacy that more is better is so entrenched into the American way of thinking that even studies that indicate that more is not better in biology seem baffling to the intellect and are often disregarded. Originally, when they started to develop chlorination for water to purify it of bacteria, they found that smaller amounts of chlorine seemed to work better than larger amounts, but this was baffling to the minds of the developers of the chlorination process. Thus they rejected this precept and put in larger amounts of chlorine to manage water. Even though the chlorine or fluorine might have had detrimental risks, the fact was that long-term health was not their goal; their goal was to reduce the amount of bacteria in the water.

Other hormone research has shown how factors of thyroid hormone can have dramatic effects on biology, even at concentrations below 10⁻¹⁰. Sometimes just one molecule per cell can have profound effects to prevent blood clotting, change muscle contraction, control urinary secretion, control liver functioning, make or break hyper-immune reactions, and control the polarization and depolarization of cell membranes. Some of the more important research has shown that hormones have been found in different percentages to have profoundly different effects.

As Isaacs pointed out, the difference between an alpha and beta receptor is not a profound difference in the hormone, but a difference in the concentration. The new science of hormesis has given us explanations for understanding some of the processes of the Arndt-Schultz law of pharmacology and Wilder's law of initial values.

Just as various pH detectors are sensitive to various pH and might turn a different color, we can also see that concentrations of hormones could have varying effects on receptor sites. Grape juice has a certain pH factor characterized by its color. As we bring it more toward neutrality by adding water, there is a subtle change as it approaches more of the neutral pH. This change in color is shown as a much softer blue. This is a pH factor, not related directly to dilution.

There are many dyes in the plant and animal kingdom that are pH-sensitive, and they sense the amount of negative or positive ions in a concentration. Many receptor sites are also hormonal concentration-sensitive. Thus the alpha and beta receptors are not sparked by different hormones, but by the concentration of those hormones.

As we understand more about biology, seeing it through a new nonlinear system in which more is not better, we must cultivate an understanding of how biology can respond to very, very small stimuli, including polymorphic shapes, quantum energy patterns, liquid crystal functions, and perhaps even other dimensional states. We can understand more of the effects that homeopathy and vibrational medicine can have on the human being.

A thorough review of the literature regarding hormesis is recommended at this point.

In the field of hormesis, recent studies have found that small amounts of toxic elements can have stimulatory and profoundly positive effects on various organisms. At the University of Wyoming

studies have shown how small amounts of radiation and other toxins can have positive effects on enhancing the life span of insects and small mammals. Hormesis has been found to have very positive effects and ramifications for biology. Hormesis is a pinnacle example of the Arndt-Schultz law, and how small amounts of toxic elements can have the reverse effect on biology.

We can see that the classical homeopaths, stretching back two hundred years, have described a very profound modality of medicine that screams for more understanding, provided that the practitioner has the tools for understanding needed to evolve the thought process beyond the linear, reductionistic mode.

For a complete study on some of the effects of homeopathy and proof of its existence as a medical modality, we wish to point the reader at this time to The Natural Repertory of Dr. Nelson, which will describe scientific research, pointing out not only the efficacy, but also some theories of philosophy regarding the use of allersodes, nosodes, isodes, sarcodes, and combinations.

IATROGENIC AUTO-AGGRESSION DISEASE

AUTO-IMMUNE DYSFUNCTION

ANTI-BODY FORMATION

AUTO SYSTEM

DISEASE LIKELY TO BE
CAUSED BY IATROGENIC

Nervous System -----	Encephalomyelitis, neuritis, polyneuritis, multiple sclerosis, optical neuritis, ophthalmia.
Articulations -----	Arthritis, polyarthritis, coxitis, paraheumatic illness
Lungs -----	Eosinophilic infiltration, TBC caverns
Bone Marrow -----	Agranulozytosis, leukemia, osteomyelosclerosis, thrombopenia, idiopathic leucopenia, hemolytic anemia

Vessels -----	Hemorrhagic gangrene, peri- arteritis nodosa, vasculitis, thrombocytopenic purpura
Heart -----	Endomyocarditis rheumatica, angina pectoris
Liver -----	Fatty liver, frosted liver, indurated liver, lardaceous liver, saffron liver, yellow liver, chronic hepatitis, cirrhosis, dysprotein anemia, para protein anemia,
Kidneys -----	Albuminuria, acute glomerulo- nephritis, nephrosis, nephro- sclerosis, amyloidosis
Connective Tissue -----	Collagenosis, sclerodermy, fibrosis, sclerodermy, erythematodes, dermatomyosis, amyloidosis, hyalin- ization, fibroplasy

1. The cell and cell injury

STRUCTURE AND FUNCTION OF CELL COMPONENTS

Nucleus

The nucleus is composed principally of deoxyribonucleic acid (DNA) in combination with a protein (histone) within a ground substance. The nucleic acid material (chromatin) stains well with basic dyes such as haematoxylin and methylene blue, and DNA can be stained specifically by the Feulgen technique. Chromatin patterns vary from cell to cell. The plasma cell, for example, has a distinctive 'cartwheel' pattern. The nucleus is separated from the cytoplasm by a double membrane - the nuclear envelope - containing circular holes 50 to 70 nm in diameter - nuclear pores. The pores, which are usually crossed by a diffuse membrane, probably represent the sites of interchange between nucleus and cytoplasm.

Functions of the nucleus

1. Replication of DNA
2. Production of messenger RNA
3. Synthesis of some nuclear proteins

Nucleolus

The nucleus normally contains one or more small basophilic structures - nucleoli, composed of a dense network (nucleolonema) enclosing paler areas (the pars amorpha). The granules of the nucleolonema are thought to represent newly-synthesised ribosome subunits which pass out of the nucleus along with messenger RNA and direct the synthesis of specific proteins in the cytoplasm.

Cytoplasm

Cytosol differs from extracellular fluid in having a high concentration of potassium, magnesium and phosphate. Sodium is actively excluded by the ATP-dependent 'sodium-pump' across the cell membrane. Many functions reside in the cytosol or cytoplasmic matrix, namely:

1. Glycolysis
2. Some reactions in gluconeogenesis
3. Activation and synthesis of some amino acids
4. Fatty acid synthesis
5. Mononucleotide synthesis
6. Phosphogluconate pathway
7. Second messenger signalling pathways

Mitochondria

These round, ovoid, or sinuous cytoplasmic organelles possess a complete outer trilaminar membrane and an inner membrane which shows numerous infoldings termed cristae. Although all mitochondria have this basic structure there is considerable variability both in the number and length of the cristae and in the number and general outline of the mitochondria. Cells with a high metabolic activity have large mitochondria with numerous cristae, for example cardiac muscle and gastric parietal cells. In the liver, whilst the mitochondria are large, the cristae are sparse and irregular. Mitochondria contain most of the enzymes of the citric acid cycle and the energy derived from the oxidation of acetyl Co-A in the cycle is used to convert adenosine diphosphate to triphosphate - oxidative phosphorylation.

Endoplasmic reticulum

All cells contain a system of complex paired membranes enclosing small vesicles or channels - the cisternae. These membranes form the endoplasmic reticulum (ER) and are either studded with ribosomes forming so-called rough ER or are devoid of granules and are termed smooth ER. The main function of the rough ER, together with free ribosomes in the cytoplasm, is protein synthesis. Protein produced by the rough ER is usually for export via the Golgi apparatus. Ribosomes are basophilic so that the cytoplasm of cells capable of rapid protein synthesis stains well with

haematoxylin or pyronin. Examples of cells showing such cytoplasmic basophilia are plasma cells, exocrine cells of the pancreas, and hepatocytes. The smooth ER is concerned with synthesis of triglycerides from free fatty acids, drug metabolism and detoxification, glycogen synthesis, and the synthesis of steroid hormones. Cells rich in smooth ER (as well as mitochondria) show a greater affinity for acidic dyes such as eosin and acid fuchsin.

The Golgi apparatus

The Golgi apparatus is a series of membrane lamellae, membranebound vacuoles and small vesicles, best seen in secretory cells such as those of the exocrine pancreas, goblet cells, and the absorptive cells of the gut. The Golgi is thought to package secretions which reach it through the cisternae of the ER. The secretion granules then bud off and migrate to the apex of the cell.

Microfilaments

Microfilaments are thin filaments with an average diameter of 6 nm composed of polymerised actin. They are usually found in bundles within a network and are important in retaining the shape of cells and in cell motility.

Microtubules

Microtubules are non-contractile structures, about 25 nm in diameter, and of variable length. They are composed of subunits (dimers) of tubulin which can be rapidly re-assembled thus providing a dynamic cytoskeleton, and are found in cilia and flagella as well as forming mitotic spindles and centrioles in all types of cells. Microtubules are involved in:

1. Maintaining the cytoskeleton
2. Mitotic division
3. Transport pathways for secretions and other organelles
4. Ciliary activity
5. Phagocytosis
6. Sensory transduction, e.g. in polymorphs
7. Cell motility

Intermediate filaments

Intermediate filaments are tubular structures 7-11 nm in diameter composed of polymers of one or more (up to 10) polypeptides. The various polymers show a degree of tissue specificity and their detection has proved useful in the characterisation of tumour cells. Tissue specificity is as follows:

1. Vimentin - mesenchymal cells
2. Desmin - muscle cells
3. Cytokeratins - epithelial cells
4. Neurofilaments - neurones
5. Glial fibrillary acidic protein - glial cells

Lysosomes

These are rounded, membrane-bound bodies showing wide variation in their size, shape, and internal structure. They are the main components of an intracellular digestive system and contain numerous hydrolases active at acid pH, such as phosphatase, betaglucuronidase, esterases, ribonuclease and deoxyribonuclease. The digestive activity is generally contained within the lysosomes themselves. In heterophagy exogenous material enters the cell by endocytosis and the vacuole thus formed fuses with primary lysosomes, probably produced by the Golgi apparatus. In autophagy, damaged cytoplasmic components are enveloped to form an autophagic vacuole which fuses with primary lysosomes. Digestion proceeds in the secondary lysosomes so-formed and products diffuse out to be re-utilised by the cell. Undigested material can in some instances be expelled by exocytosis, otherwise it remains in the cell as a residual dense body.

Examples of proteins taken into cells and digested within lysosomes are:

1. Haemoglobin
2. Native immunoglobulin and immune complexes
3. Denatured proteins
4. Protein reabsorption in renal tubules

Lysosomes are important in:

1. Polymorphs and macrophages in killing and digesting infective agents
2. Removal of unwanted cells during embryonic development
3. Disposal of excess secretory products in glandular cells
4. Osteoclastic remodelling of bone by secreted enzymes
5. Supply of nutrients, e.g. in liver

Microbodies

Microbodies or peroxisomes consist of a homogeneous matrix sometimes containing a central crystalline nucleus enclosed in a single membrane. They contain a number of enzymes, including amino-acid oxidases, urate oxidase and catalase, and are most numerous in liver and kidney cells. Their role in the cell economy is obscure but one of their functions may be the regulation of blood lipid levels.

Cell membrane

Cells are enclosed by a unit membrane composed of lipids, proteins, and oligo- and polysaccharides. The membrane is essentially a phospholipid bilayer with the hydrophobic lipid moieties internalised and the proteins (and glycoproteins) present as:

1. Integral membrane proteins - globular proteins intercalated to varying depths within the bilayer and in some instances completely spanning the membrane. Integrated glycoproteins are always arranged so that their carbohydrate moieties are exposed at the cell surface where they act as specific receptor molecules. Whilst some integral proteins are capable of lateral movement within the lipid bilayer (thus altering the molecular pattern presented at the surface) others appear to be attached to microtubules and microfilaments and mediate

'transmembrane cytoskeletal control'

2. Peripheral membrane proteins - are not essential to structural integrity and are bound to integral proteins or glycolipids by ionic bonds.

The cell membrane has a number of important functions:

1. Intake of exogenous material by phagocytosis, pinocytosis or micropinocytosis
2. Selective permeability
3. The ATP-associated sodium-pump which actively shifts sodium ions across the membrane out of the cytoplasm
4. Cell-to-cell contact and adhesion by means of junctional complexes - tight junction, intermediate junction, and desmosome
5. Contact inhibition - the mechanism whereby further proliferation and movement of cells is inhibited by contact with like cells
6. Antigenicity (histocompatibility)
7. Recognition - the capacity to recognise foreign antigens and altered or effete host cells, resides at the cell membrane and is mediated by cell-bound antibodies or antibody-like molecules
8. Receptor sites for stimulatory hormones, cytokines and other chemical mediators.

PROTEOLYSIS AND PROTEIN FOLDING

While it is self evident that rapid and efficient proteolysis is central to the proper functioning of the cell; it is only recently that the mechanisms controlling proteolysis have begun to be understood. For instance, there is a very close connection between proteolysis and control of the cell cycle. Indeed a single protein, cyclin B, which accumulates during the G1 and S phases must be degraded for cells to exit mitosis. One of the major factors in the regulation of such degradation is the protein ubiquitin. As its name implies, this protein is highly conserved throughout eukaryotes, and is unique in its ability to become reversibly cross-linked to other proteins. In doing so it is likely that ubiquitin serves as a movable binding site for proteins that do not have complementary structures and by bringing such proteins into close association is an essential component of many important proteolytic pathways.

The proper functioning of newly synthesised proteins is dependent upon them attaining the correct three dimensional configuration. The complex folding of polypeptides involved in this process is controlled by other proteins which are either enzymes promoting disulphide formation and isomerisation, or members of a family of proteins which stabilise unfolded and partially folded structures and prevent the development of inappropriate intra- and inter-chain bonds. They achieve this without themselves becoming incorporated into the structure. These proteins are termed chaperones and are vital to the correct translocation, assembly, disassembly and transport of polypeptides and protein oligomers. The proteins first came to notice when found in excessive amounts as part of the cellular response to high temperature, hence the name 'heat-shock' proteins. Now that it is appreciated that they are essential to normal function and increased in many forms of injury they are termed stress proteins and chaperonins.

CELL - CELL ADHESION

1. Junctional mechanisms

(i) Desmosomes - intercellular junctions linked to the intermediate filaments of the cytoskeleton. They are composed of a series of transmembrane glycoproteins and proteins termed desmogleins and desmoplakins

(ii) Adherens junctions which contain different forms of transmembrane adhesion molecules, the main members being the cadherin family. These molecules are responsible for calcium dependent intercellular adhesion.

Other junctions between cells, namely gap and tight junctions, are not adhesive structures. Their function is to allow the passage of small molecules into, or between, cells.

2. Non-junctional mechanisms

Intercellular adhesion is also facilitated by membrane-bound cell adhesion molecules (CAMs). Some CAMs are specific to certain tissues whereas others, for example so-called liver cell adhesion molecule (L-CAM), are widely distributed in epithelial and other tissues. The existence of non-specific adhesion molecules means that only a small repertoire of such molecules is required for adhesion between a multiplicity of cell types.

CELL - MATRIX ADHESION

1. Junctional mechanisms

(i) Hemidesmosomes bind cells to their substratum

(ii) Focal contacts

2. Non-junctional mechanisms

The cell surface is equipped with a variety of receptors for extracellular matrix molecules such as fibronectin and laminin. The major receptors are members of the integrin family. Integrins are heterodimers that recognise and bind to a specific amino-acid sequence in the matrix molecule. They are transmembrane proteins whose cytoplasmic domains interact through intermediate proteins such as vinculin or talin to bind to actin microfilaments. Thus integrins act as an important bridge between basement membrane or connective tissue matrix proteins and intra-cytoplasmic microfilaments and permit anchorage of cells to matrix components.

THE CELL CYCLE AND CELL REPRODUCTION

After division (mitosis) the cell enters the first resting phase - G1 (Gap 1). This phase is variable and in some cells may be so prolonged that they are effectively out of cycle (Go). They may return to the cycle or become fully differentiated 'end-cells' incapable of division. S-phase is concerned with the synthesis of DNA and histones taking the cell up to a tetraploid state. At the same time there is parallel synthesis of RNA and proteins. The cell then enters a second, brief resting phase - G2 (Gap 2) which is followed by mitosis. If both 'daughter' cells enter the replicative cycle then the total number of cells will double with each generation and the population will grow exponentially. Whilst this does occur in the early stages of embryonic life, later in development the cells do not immediately enter the cycle so that doubling times are prolonged.

Two categories of dividing cells are recognised, stem cells and progeny cells:

1. Stem cells are capable of producing different forms of progeny cell. When they divide they give rise to one replacement stem cell and one dividing progeny cell.
2. Progeny cells divide but also differentiate into one or more types of specialised cells. Thus, the progeny cell pool gradually diverges in form and function and is only renewed by input from the stem cells.

The rate of growth of a tissue is a function of the frequency with which stem cells reproduce and supply the progeny pool and the number of 'amplifying' divisions undergone by the progeny cells during their lifetime. The number of such amplifying divisions is modified by:

1. The spatial distribution of cells within a tissue
2. Surface attachments
3. Cytokines and their receptors

CYTOKINES

Cytokines are a family of glycosylated or non glycosylated polypeptides and proteins secreted by cells in response to a stimulus which modulates the behaviour of target cells. They exert their effects in three ways:

- (i) They act on the cell producing them - an autocrine effect
- (ii) They act on cells in the vicinity of the producing cell - a paracrine effect
- (iii) They act systemically on distant sites - an endocrine effect.

Classes of cytokines

1. Growth factors
2. Colony stimulating factors
3. Interleukins
4. Tumour necrosis factors
5. Interferons

Growth factors and colony stimulating factors are involved in cell proliferation and differentiation in a wide variety of tissues. The major activities of interleukins, tumour necrosis factors and interferons are concerned with the immune response and inflammation and will be considered later.

1. Growth factors (GFs)

These are small polypeptides produced by various cells. They have a number of actions, the most important of which are the control of cell proliferation and differentiation..

- (i) Epidermal growth factor family
 - a. Epidermal growth factor

Transforming growth factor

Amphiregulin

These GFs are produced by many cell types. They interact with the erb-B family of receptors and are important in epithelial cell proliferation and differentiation

(ii) Platelet derived growth factor (PDGF)

Dimers of two subunits PDGF-A and PDGF-B produced by platelets, endothelial cells, activated macrophages etc., important in tissue repair and chronic inflammatory processes

(iii) Transforming growth factor family

- TGF β 1-3 (major actions - growth regulation, connective tissue synthesis)
- BMP2A, 2B and 3 (bone morphogenesis)
- Inhibins A and B (regulation of pituitary gonad axis)
- Activin A and AB (antagonism of inhibins actions)
- Mullerian inhibitory substance (development of male reproductive system)

(iv) Fibroblast growth factor (FGF)

- Acidic FGF
- Basic FGF
- int 2
- FGF5
- hst

These GFs are potent stimulatory factors for neuroectodermal cells, endothelial cells, fibroblasts etc., and play a major role in embryogenesis

(v) Insulin-like growth factor

- Type I
- Type II

Mediate action of hormones such as growth hormone

(vi) Nerve growth factors

- Nerve growth factor
- Neuroleukin

Neurotropic factors for neural tissues which play a role in wound healing

2. Colony stimulating factors

Regulate the proliferation and differentiation of haematopoietic cells.

CSF	Principal source	Major action
GM-CSF (granulocyte / Regulation macrophage)	T lymphocytes and many other cells types	Proliferation of granulocytes and macrophages. And activation of granulocytes and macrophages for host defence
G-CSF (granulocyte)	Monocytes, fibroblasts and endothelium	Enhances granulocyte productions and activation
M-CSF (macrophage)	Monocytes, fibroblasts and endothelium	Chemotatic Activation of macrophages and secretion of IL-1 and prostaglandin E
Erythropoietin	Kidney and some other cell types	Differentiatin or erythroid precursors

CYTOKINE RECEPTORS

Receptors consist of

- an external domain which is the binding site for the ligand
- a transmembrane region which spans the cell membrane
- an intracellular domain which delivers the signal to the cytosol

Receptors may consist of a single polypeptide chain on its own, e.g. EGF-R, a single polypeptide chain plus a second helper protein, e.g. IFN- γ receptor, or two polypeptide chains, e.g. IGF-1 receptor. Receptors can be of high or low affinity, e.g. IL-2, or they can have a different level of response to different ligands, e.g. IGF-1 receptor binding IGF-1 and insulin.

Receptor modulation is achieved by altering:

- the rate of synthesis and membrane insertion
- receptor internalisation and recycling
- receptor degradation via lysosomes

Signal transduction

Following binding of cytokine with its appropriate receptor there follows a cascade of events that eventually (after several hours) lead to stimulation of DNA synthesis and cell division or induction of mRNA and protein synthesis. The mechanisms involved in this 'signal transduction' are highly complex. Some receptors operate through activation of their internal tyrosine kinase domain, e.g. erb-B family, PDGF-r, IGF1-r; others transduce their signals via cytoplasmic tyrosine or serine/threonine kinases, e.g. src, yes, fgr; yet others operate through phospholipase-C activity, e.g. crk.

These enzymes act through a series of intermediaries and protein phosphorylation to 'switch on' DNA and protein synthesis.

Generation of inositol triphosphate through phospholipase-C activity leads to mobilisation of calcium ions from internal pools and thereby modulates many calcium-dependent processes. This is an example of calcium ions acting as a 'second messenger'.

Calcium fluxes in cell regulation

Although extracellular fluid has a high Ca²⁺ concentration (10⁻³ M), intracellular levels are several orders lower (about 10⁻⁶ M). This steep electrochemical gradient is maintained by the relative impermeability of the plasma membrane to calcium ions, and by active exclusion by a calcium pump. When a cell is activated, for example by a cytokine, hormone or nerve impulse, calcium ions move into the cell cytoplasm.

The ions originate either from:

1. Extracellular calcium ions which enter through:
 - (i) Receptor operated channels
 - (ii) Voltage dependent channels
2. Calcium 'stores' in the smooth endoplasmic reticulum The influx of calcium ions leads to the activation of a calcium-binding protein calmodulin. The active calmodulin-calcium complex regulates a wide range of intracellular processes

including:

1. Cyclic nucleotide metabolism
2. Microfilament polymerisation
3. Microtubule assembly-disassembly
4. Secretion, e.g. in enterocytes and in the exocrine pancreas
5. Glycogen metabolism

CAUSES OF CELL INJURY

1. Toxic substances

- (i) Biochemically specific - enzyme poisons such as cyanide on cytochrome oxidase; sodium fluoracetate block of the Krebs cycle
- (ii) Tissue specific - e.g. paracetamol (acetaminophen) producing liver necrosis; alloxan giving rise to necrosis in B-cells of the pancreatic islets
- (iii) General - e.g. ethyl alcohol, psychotropic drugs, heavy metal poisons

2. Physical agents

- (i) Trauma
- (ii) Temperature injuries, i.e. extreme heat or cold
- (iii) Pressure effects (blast injuries)

(iv) Ionising radiation

(v) Electrical injuries

3. Lack of nutrients

Local

- (i) Failure of cellular absorption, e.g. glucose in diabetes mellitus
- (ii) Failure of blood supply – ischaemia

General

- (i) Hypoxia, e.g. severe anaemia, respiratory failure
- (ii) Malnutrition resulting from dietary deficiency or malabsorption
- (iii) Hormonal deficiency

4. Infective agents and parasites

Injure by

- (i) Production of toxins, exotoxins and endotoxins (lipopolysaccharide)
- (ii) Competition for essential nutrients
- (iii) Provocation of an inflammatory cell or immune response
- (iv) Intracellular multiplication

5. Immune mechanisms

- (i) Autoimmune diseases
- (ii) Hypersensitivity states, e.g. contact dermatitis

6. Genetic defects

- (i) Change in chromosome make-up
 - a. Alteration in number - aneuploidy
 - b. Alteration in structure as a result of chromosomal deletion or translocation
- (ii) Change in genetic code
 - a. Inherited, e.g. inborn errors of metabolism, thalassaemia
 - b. Acquired
 - Mutation
 - Deletion of gene

EVOLUTION OF CELL INJURY

The term 'injury' embraces a wide range of adverse events which will affect cellular homeostasis. Where an injury is mild and transient the cell may suffer limited damage to membranes and organelles which can be readily repaired and normal structure and function restored. Such injuries induce increased synthesis of specific stress proteins which could help in the dissociation

and clearance of denatured proteins and protein complexes, and satisfy the greater demand for protein folding brought about by the adverse conditions. Unwanted or effete organelles and membranes are removed by autophagocytosis.

More severe and sustained injury may result in degenerative changes such as cloudy swelling and fat accumulation which, if the injurious agent is withdrawn, are also reversible and the cell recovers. If, however, the injury persists the cell may degenerate further, become irreversibly damaged, and die. In some circumstances the injury may be so catastrophic that the cell dies without showing these intermediate changes.

Alternatively, when an adverse environment persists, the cell may adapt and establish a new steady state. Only when the cell fails to establish an altered level of homeostasis in response to injury is cell death inevitable. Under some circumstances the new environment may require a heightened state of activity for homeostasis to be maintained. Increased functional activity is brought about by an increase in the number of organelles and a concomitant increase in cell size - cellular hypertrophy. An increase in cell number may be required to cope with increased demands or to compensate for a shortened life span - hyperplasia. More frequently, a cell adapts to an adverse environment by functioning at a lower level than normal. The diminution in functional organelles is paralleled by reduced cell size - atrophy. Finally tissues exposed to an adverse environment over a sustained period may adapt by altering the direction of cellular differentiation to produce cells more capable of combating the environment. Such a change is termed metaplasia.

SUBLETHAL CELL INJURY

Sublethal injury may result in long-term adaptive changes or in degenerative changes which can be reversed but might also herald the onset of cell death. The degenerative consequences of cell injury comprise:

1. Injury to cell membranes and mitochondria

- (i) Loss of microvilli and focal expansions of the plasma membrane
- (ii) Formation of vacuoles by enfolding of the plasma membrane - endocytic vacuolation
- (iii) Disruption of the RER and loss of ribosomes. This brings about the loss of cytoplasmic basophilia seen on light microscopy
- (iv) Mitochondrial swelling and loss of cristae

2. Cloudy swelling (intracellular oedema)

This results from the accumulation of watery fluid in the dilated sacs or cisternae of the endoplasmic reticulum and mitochondria.

- (i) Early stages - under the light microscope, the cytoplasm has a fine granularity like ground-glass
- (ii) Later stages - progressive dilatation of the ER leads to the appearance of clear vacuoles visible by light microscopy - hydropic vacuolation

Mechanism

- (i) Fall in oxidative phosphorylation due to
 - a. Lack of oxygen

- b. Damage to mitochondria or its enzymatic pathways

The diminished formation of ATP affects all the energy requiring reactions in the cell but in particular leads to failure of the sodium-pump. Sodium ions enter the cell in exchange for potassium and as the former have a larger hydration shell, there is a net influx of water.

- (ii) Increased intracellular osmotic pressure resulting from
 - a. Accumulation of lactate and pyruvate
 - b. Net catabolism of macromolecules

3. Fatty change

This is the appearance of abundant spherical globules of fat (triglyceride) within the cytoplasm. It can be demonstrated using frozen sections and staining with lipid-soluble dyes such as Oil red O or Sudan black, and is most commonly seen in cells of the liver, kidney and myocardium. Fatty change must be distinguished from pathological adiposity where fat cells (lipocytes) infiltrate an organ or tissue. This is a feature of severe obesity. In normal cells fat is held in a dispersed state and transported out of the cell as micelles or lipoprotein complexes (triglyceride with phospholipid and/or protein). Triglycerides are synthesised from free fatty acids (FFAs) entering the cell from the blood. FFAs also undergo oxidation to CO₂ and conversion to phospholipid.

Mechanism

Fatty change results from:

A. Impaired metabolism of fat

- (i) Reduced oxidation of FFAs with increased conversion to triglycerides
- (ii) Reduced synthesis of phospholipid and protein. This results in
 - a. Reduced dispersal of fat leading to globule formation
 - b. Diminished release of fat from the cell as lipoprotein

B. Excessive entry of FFAs and triglyceride into the cell

Causes

- (i) Diabetes mellitus
- (ii) Congestive cardiac failure
- (iii) Severe anaemia
- (iv) Malnutrition and wasting disease
- (v) Ischaemia, e.g. coronary insufficiency
- (vi) Infections (septicaemia)
- (vii) Chronic alcoholism (liver)
- (viii) Poisons, e.g. carbon tetrachloride, phosphorus (liver)

4. Lysosomal damage

A. Lysosomal rupture is thought to be responsible for some forms of cell injury, e.g. injury to alveolar macrophages after phagocytosis of silica. In toxic injury, however, rupture is thought to be a consequence of advanced cellular damage rather than an initiating factor.

B. Lysosomal overloading. Many metabolic processes depend upon the hydrolysis of intermediates by lysosomal enzymes. When a particular hydrolase is deficient or absent, all substances entering lysosomes or arising within them that require this enzyme for their further digestion, accumulate and progressively enlarge the lysosome.

Substances accumulating in this way include:

- (i) Lipofuscin (see below)
- (ii) Glycogen - Type 11 storage disease (Pompe)
- (iii) Protein - forming the hyaline deposits in kidney tubule cells in the nephrotic syndrome
- (iv) Lipids - Gaucher's disease (glucoceramide) Niemann-Pick disease (sphingomyelin), Tay-Sachs disease (gangliosides)
- (v) Mucopolysaccharide - Hurler's syndrome (gargoylism)
- (vi) Cystine - cystinosis

5. Sublethal nuclear injury

A. Inclusions

- (i) False inclusions resulting from invagination of the nuclear membrane
- (ii) Abnormal deposits of glycogen, lamellar bodies, etc.
- (iii) Viral inclusions, e.g. herpes

B. Abnormal DNA-dependent RNA synthesis

C. DNA damage

Ionising radiation and certain chemical compounds such as the mustards and ethyleneimides exert their toxic effects principally on cell nuclei. High doses result in cell death, but smaller doses may produce:

- (i) Mutations. Latent injury to DNA may result in mutation and the development of malignant cells.
- (ii) Genetic abnormalities. Similar injury to germ cells may produce changes in the DNA code which result in genetic abnormalities in the offspring.

6. Excessive or abnormal products

- (i) Excess of normal secretions, e.g. mucus
- (ii) Amyloid
- (iii) Basement membrane-like material
- (iv) Calcification
- (v) Mallory's hyaline

7. Accumulation of lipofuscins

These are widely distributed brown-pigments derived from the oxidation of lipids and are of heterogeneous composition. The pigment is seen in the following situations:

- (i) In certain apparently normal cells
 - a. Epithelial cells of the epididymis
 - b. Interstitial cells of the testis
 - c. Ganglion cells and neurones
- (ii) In ageing cells - so-called 'wear-and-tear' pigment. This is best seen in 'permanent' tissues such as myocardium where the fibres show increasing pigmentation with age. It is particularly evident where the heart has atrophied as a result of wasting disease - 'brown atrophy'. Also seen in liver cells with increasing age and with certain drugs, e.g. phenobarbitone
- (iii) As 'ceroid' pigment in the liver after liver cell necrosis and oxidation of lipid membranes, e.g. after viral hepatitis, drug hepatotoxicity
- (iv) In liver cells in the Dubin-Johnson syndrome
- (v) In the 'brown-bowel' syndrome. Pigmentation of smooth muscle cells accompanies various malabsorption states

LETHAL CELL INJURY

An immediate consequence of damage to the plasma membrane is altered permeability with an influx of calcium ions. The ensuing disturbance of intracellular calcium homeostasis has far-reaching effects on cellular function and sets in train (or accelerates) the metabolic changes that will lead to cell death.

These include:

1. Cessation of oxidative phosphorylation in damaged mitochondria
2. Failure of ATP-dependent pumps so that more calcium and sodium ions enter the cell (together with water) and potassium ions pass out. With advancing membrane disruption, semipermeability is lost and the influx of water ceases.
3. Disordered nuclear function and a decrease in DNA-dependent RNA synthesis

- Continuing anaerobic glycolysis leads to a fall in pH which activates hydrolytic enzymes escaping from damaged lysosomes and accelerates autolysis.

It seems likely that plasma membrane injury caused by a wide variety of agents inevitably leads to a rapid influx of calcium ions and that this influx initiates a final common pathway of metabolic disturbances leading to cell death.

Cell death is recognised by:

1. Ultrastructural changes

- Margination or progressive loss of nuclear chromatin
- Focal rupture of the nuclear membrane
- Breakdown of the plasmalemma
- Development of flocculent densities in mitochondria

2. Changes in the nucleus

- Swelling and clumping of chromatin
- Pyknosis - condensation of chromatin and shrinkage of the nucleus
- Karyorrhexis - fragmentation of the nucleus
- Karyolysis - dissolution of the nucleus by deoxyribonuclease

3. Changes in the cytoplasmic staining

- Positive staining with vital dyes such as trypan blue, which reflects abnormal membrane permeability. Viable cells are impermeable to these dyes.
- Opacification - denaturation of proteins leads to aggregation with resultant opacification of the cytoplasm
- Eosinophilia - exposure of basic amino groups results in increased affinity for acidic dyes such as eosin

4. Biochemical changes

- Release of K⁺ by dead cells
- Release of enzymes into the blood, e.g. increased plasma levels of creatine kinases, lactic dehydrogenase and aspartate aminotransferase (formerly GOT)
- Release of protein or protein breakdown products into the blood, e.g. myoglobin from injured skeletal muscle cells.

CELL DEATH AND NECROSIS

Cell death occurs at the point where injury becomes irreversible. The dead cell then enters a phase in which there is progressive degradation brought about by denaturation and hydrolysis of cell constituents - this is necrosis. The term autolysis is sometimes applied to degradation associated with somatic death but the distinction from necrosis following individual or multiple cell death is artificial.

APOPTOSIS

Apoptosis is a form of cell death in which single cells are eliminated from living tissue.

In apoptosis the cell passes through the following stages:

- Condensation of chromatin in the nucleus
- Deep invaginations of the nuclear membrane
- Fragmentation of the nucleus
- Contraction of the cytosol and aggregation of cytoplasmic organelles
- Budding and separation of membrane-bound bodies containing condensed organelles and nuclear fragments

This converts the cell into several small apoptotic bodies which are usually phagocytosed by surrounding healthy tissue cells or by macrophages.

Apoptosis does not provoke an acute inflammatory response and large numbers of cells can be eliminated from tissues without disturbing the basic architecture. This is the mode of cell death seen in normal cell-turnover and in the following situations:

- Embryological development and metamorphosis
- Atrophy, which may be either physiological (involution) or pathological
- Spontaneous cell-deletion in tumours
- In certain viral infections, for example those affecting the liver, viral hepatitis, yellow fever,
- Cells dying as a result of a cytotoxic T-lymphocyte attack, for example in chronic active hepatitis graft-versus-host reactions
- Irradiation and chemotherapy applied at doses lower than those which cause frank necrosis
- Clonal selection in the immune system

Apoptosis has been termed 'programmed cell death' and is brought about by a stereotyped mechanism involving calcium and magnesium-dependent endonucleases which cleave nuclear DNA and other effector molecules which require continuing synthetic activity by the cell. It is reasonable to assume that apoptosis is to some extent under genetic control and two genes claimed to be involved in programmed cell death have recently been partly characterised, but changes in the immediate environment of the cell are of crucial importance. The effect of these environmental signals will differ according to the cell type and to its stage of development or maturation. Furthermore, apoptosis may be induced by the appearance of a stimulus as when immature thymocytes are exposed to glucocorticoids, or when a stimulus is withdrawn such as

removal of interleukin-2 from mature T lymphocytes.

FORMS OF NECROSIS

A. General forms

1. Coagulative necrosis
 - (i) Architecture preserved, e.g. renal infarct, syphilitic gumma
 - (ii) Architecture destroyed, e.g. caseous necrosis in tuberculosis
2. Colliquative necrosis - necrosis and liquefaction, e.g. cerebral infarct

B. Special forms

1. Fat necrosis
 - (i) Traumatic - release of lipid from fat cells provokes a chronic inflammatory and giant cell response as seen in subcutaneous fat or the breast
 - (ii) Enzymatic - as occurs in association with acute pancreatitis
2. Fibrinoid 'necrosis' - this is not a true necrosis but a strongly eosinophilic degeneration of collagen, e.g. in a rheumatoid nodule; or in polyarteritis nodosa. A similar appearance may result from:
 - (i) Deposition of fibrin
 - (ii) Deposition of antigen-antibody complexes
 - (iii) Necrosis of smooth muscle
3. Gangrene

CONSEQUENCES OF NECROSIS

1. Acute inflammation
2. Healing by repair or regeneration
3. Chronic inflammation
4. Immunological reactions to subcellular components released by dead tissue, or to self-antigens altered by denaturation, e.g. the post-myocardial infarction syndrome
5. Calcification, e.g. in old caseous foci of tuberculosis

CE
cell phones
do affect
the brain

the shields
can help a little
BUT

SCIO



The SCIO can undo the damage by regulating and
balancing the
Body Electric's Regulatory Processes
+ increasing VARHOP

If you need more information on the SCIO and purchase details please get in touch with us

Maitreya Kft.

tel: +3613036043 | web: www.qxsubspace.com | e-mail: info@qxsubspace.com



2. Cellular adaption and ageing

ATROPHY

Atrophy is the acquired diminution in size of an organ or tissue brought about by loss or decrease in size of its constituent cells. Loss of cells is by single-cell necrosis (apoptosis). Reduction in size of cells is a result of disturbed intermediary metabolism with decreased oxidative phosphorylation and an increase in glycolysis. There is increased focal cytoplasmic degradation and the effete intracellular components are taken into autophagic vacuoles. In some cells, e.g. liver, heart, brain, oxidised lipids derived from these membranes persist as the brown pigment lipofuscin. Evidence of other types of sublethal injury such as cloudy swelling and fatty change may precede atrophy of cells.

Atrophy must be distinguished from a failure in development of an organ or tissue.

Hypoplasia is a partial failure of development whereby an organ does not attain the normal size, e.g. hypoplasia of one or both kidneys.

Agenesis is a complete failure of development, e.g. congenital absence of one or both kidneys.

Atrophy can occur under physiological or pathological conditions:

A. Physiological atrophy

1. In the fetus
 - (i) Branchial clefts
 - (ii) Thyroglossal duct
 - (iii) Notochord
2. In the neonate
 - (i) Ductus arteriosus
 - (ii) Umbilical vessels
 - (iii) Urachus
3. Post adolescence
 - (i) Lymphoid tissue
 - a. Tonsils
 - b. Mesenteric lymph nodes
 - c. Appendix
 - d. Thymus
4. In the adult
 - (i) Post-partum involution of the uterus
 - (ii) Post-lactational atrophy of the breasts
 - (iii) Post-menopausal atrophy of the uterus, ovaries, and breasts

B. Pathological atrophy

1. Localised atrophy
 - (i) Ischaemia, e.g. cerebral atrophy due to atherosclerosis
 - (ii) Pressure
 - a. Aortic aneurysm eroding bone
 - b. Meningioma causing atrophy of overlying skull
 - c. Hydronephrosis producing atrophy of the kidney parenchyma
 - (iii) Disuse
 - a. Local osteoporosis and muscular atrophy resulting from immobilisation
 - b. Obstruction of a duct draining an exocrine gland leads to atrophy of the glandular elements, e.g. salivary gland
 - (iv) Autoimmune
 - a. Adrenal atrophy in idiopathic Addison's disease
 - b. Gastric parietal-cell atrophy in pernicious anaemia
 - (v) Hormone withdrawal
 - a. Endometrial atrophy after oestrogen withdrawal
 - b. Testicular atrophy, in cirrhosis, oestrogen therapy, etc.
 - (vi) Neuropathic
 - a. Muscle atrophy following loss of nerve supply
 - (vii) Idiopathic
 - a. Villous atrophy in coeliac disease
 2. Generalised atrophy results from:
 - (i) Sustained increased catabolism in fever, following severe trauma, etc.
 - (ii) Simple starvation, severe malnutrition, malabsorption and malignant cachexia
 - (iii) Senility
 - (iv) Hypopituitarism
- Generalised atrophy is characterised by:*
- (i) Muscle wasting
 - (ii) Loss of adipose tissue
 - (iii) 'Brown atrophy' of the heart
 - (iv) Microsplanchnia

HYPERTROPHY

Hypertrophy is the increase in size of an organ or tissue brought about by an increase in size of its specialised cells. In a pure form, hypertrophy is found only in muscle and is usually a response to an increased demand for work. A further rare cause is the hypertrophy of the tongue and heart seen in acromegaly resulting from increased stimulation by growth hormone.

1. Cardiac muscle

- (i) Left ventricle (> 1.5 cm average thickness)
 - a. Systemic hypertension
 - b. Aortic valvular disease
 - c. Mitral incompetence
 - d. High-output states such as severe anaemia, hypercapnia, thyrotoxicosis
 - e. Hypertrophic cardiomyopathy
- (ii) Right ventricle (> 0.4 cm thickness)
 - a. Chronic lung disease - cor pulmonale
 - b. Mitral stenosis
 - c. Secondary to left ventricular failure
 - d. Congenital left to right shunts
 - e. Pulmonary or tricuspid valvular lesions

2. Skeletal muscle - exercise

3. Smooth muscle

- (i) Uterus - pregnancy
- (ii) Arteries - hypertension (medial hypertrophy)
- (iii) Alimentary tract (usually proximal to an obstruction), e.g.
 - a. Above an oesophageal stricture
 - b. Proximal to an annular carcinoma of the colon
 - c. Idiopathic hypertrophic pyloric stenosis
- (iv) Urinary bladder (obstruction to outflow)
 - a. Prostatic enlargement
 - b. Urethral stricture
 - c. Meatal stricture
 - d. Severe phimosis
 - e. Congenital bladder neck obstruction

HYPERPLASIA

Hyperplasia is an increase in size of an organ or tissue brought about by an increase in number of its specialised cells. In many cases, hyperplasia is associated with some degree of hypertrophy of individual cells.

1. Endocrine glands

- (i) Adrenal cortex
 - a. ACTH administration
 - b. Basophil adenoma of the pituitary
 - c. Idiopathic hyperplasia
 - d. Congenital adrenal hyperplasia
- (ii) Parathyroids
 - a. Primary (idiopathic) hyperplasia
 - b. Secondary to chronic renal failure
- (iii) Thyroid - primary thyrotoxicosis (Graves' disease)
- (iv) Pituitary
 - a. Acidophil hyperplasia is an occasional cause of acromegaly
 - b. Basophil hyperplasia - Cushing's syndrome
- (v) Pancreatic islets

Hyperplasia is seen in the babies of diabetic mothers

2. Endocrine target organs

- (i) Breasts
 - a. Physiological hyperplasia in pregnancy and lactation
 - b. Pathological in cystic disease of the breast
- (ii) Endometrium

Cystic hyperplasia in response to excessive oestrogen stimulation

- (iii) Prostate - benign nodular hyperplasia

3. Skin

- (i) Prickle-cell hyperplasia (acanthosis) is seen in many skin diseases including
 - a. Psoriasis (in the rete pegs)
 - b. Chronic dermatitis
 - c. Acanthosis nigricans
 - d. Viral warts
- (ii) Pseudo-epitheliomatous hyperplasia is seen

- a. In association with chronic inflammation and granulation tissue
- b. Overlying dermal tumours such as granular-cell myoblastoma
- c. In kerato-acanthoma

4. Lining epithelia

e.g. at the margins of healing ulcers in the stomach, duodenum or colon

5. Bone marrow

Hyperplasia is most commonly seen where demand for red blood cells is increased by

- (i) Haemolytic states
- (ii) Hypoxia

METAPLASIA

Metaplasia is the conversion or replacement of one normal adult cell type by a different adult (fully-differentiated) cell type. In most instances, such conversion is achieved by a change in differentiation in the progeny pool but the term is also employed where one type of epithelium is substituted by another, for example by migration from the margins of an ulcer at a junction between two epithelia. Metaplasia is usually a response to chronic irritation or inflammation and rarely does the alteration cross histogenetic boundaries.

Altered environmental factors inhibit differentiation along the usual pathway whilst promoting differentiation via some new pathway. Such factors cause cells to stop growing at different growth-arrest points thereby altering the differentiation potential of the precursor cells. However, these cells have no intrinsic defect in their regulatory processes so that further changes in the environment are capable of reversing the metaplastic process.

The appearance of different forms of epithelia within a tissue might also be due to the development of novel cell lineages whose progeny adopt a phenotype not usually found at that site. The appearance of so-called pyloric metaplasia (ulcer associated cell lineage) in the mucosa of the intestine following ulceration might arise by this mechanism.

Metaplasia can have disadvantages in that the normal function of the original cell type is lost and this may render the parent organ vulnerable to damage, e.g. loss of the mucociliary escalator when tracheo-bronchial epithelium changes to a squamous cell type.

FORMS OF METAPLASIA

A. Epithelial

- 1. Squamous metaplasia
 - (i) From pseudo-stratified columnar ciliated epithelium
 - a. In the trachea and bronchi in chronic bronchitis, cigarette smokers, bronchiectasis
 - b. In nasal sinuses, (occasionally) in chronic sinusitis and in hypovitaminosis A
 - (ii) From simple columnar epithelium
 - a. Endometrium in senility

- b. Gall-bladder in cholelithiasis
- c. Prostatic ducts in ageing and oestrogen therapy
- d. Endocervical mucosa and glands associated with cervical 'erosion'

(iii) From transitional cell epithelium

- a. Renal pelvis with calculi
- b. Urinary bladder with chronic cystitis or schistosomiasis
- (iv) From mesothelium of the pleura and peritoneum

2. Columnar metaplasia

- (i) 'Pink-cell' or apocrine metaplasia seen in cystic disease of the breast
- (ii) Intestinal metaplasia of the gastric mucosa in chronic gastritis
- (iii) In mesothelium of peritoneum, pleura and synovium

B. Connective tissue

1. Osseous metaplasia

- (i) In sites of dystrophic calcification

a. Scars

- b. Old tuberculous lesions
- c. Medial calcification of arteries

(ii) In muscle

- a. Localised myositis ossificans
- b. Post-traumatic
- c. After tetanus

d. Paraplegia

(iii) In soft tissues

- a. Tumoral calcinosis (?)
- b. Progressive fibrodysplasia ossificans
- c. Pseudo-hypoparathyroidism
- d. Hereditary osteodystrophy (Albright's)

2. Myeloid metaplasia

- a. Development of haemopoietic tissue in the metaplastic bone
- b. Extra-medullary haemopoiesis in the liver and spleen, e.g. in myelofibrosis

AGEING

The mechanisms underlying ageing at the somatic and cellular levels remain obscure. Several factors indicate a genetic basis:

1. Each species has a characteristic mean and maximum life span
2. In the human, although life expectancy has generally increased, the maximum life span remains virtually unchanged
3. Longevity has definite familial associations
4. Certain diseases with a genetic basis are associated with accelerated ageing and a diminished life span, e.g. Werner's syndrome and progeria

Research on cell culture lines has demonstrated that normal cells have a finite capacity for replication, the so-called Hayflick number. However, this limit is rarely, if ever, reached by cells in vivo so that senescence cannot be attributed solely to a failure of cell division. Nevertheless, it may be that following mitosis cells are produced which enter a permanent G0 phase and are irreversibly committed to senescence and death. Such 'committed' cells may exhibit normal growth (for a time) but dilute the fraction of cycling cells to a point where the population cannot be maintained. Strong experimental evidence for a genetic control mechanism of ageing by a family of senescence genes has accumulated. Fusion of immortal cells with normal cells can lead to senescence of the hybrid, and subsequent non-random loss of chromosomes can restore immortality. Transfection of selected chromosomes back into immortal cell lines restores senescence. The function of these genes has not yet been established.

Theories of cellular ageing

1. Random

- (i) Somatic mutation

Ageing results from random damage to DNA produced by mutagens such as radiation, viral infection, free radicals, etc., which is not adequately remedied by DNA repair. The repair mechanisms themselves may decrease in efficiency and contribute to the accumulation of mutations.

- (ii) 'Error catastrophe'

Ageing is envisaged as a deterioration in the mechanisms responsible for the accuracy of transcription and translation. Minor errors in the synthesis of proteins and, in particular, enzymes, gradually accumulate to the point where the cell can no longer survive.

2. Programmed

This theory implicates senescence or 'lethal' genes which slow down or stop vital processes. Selection or expression of such genes is seen as an active process brought about by evolutionary pressures which confer an advantage on the species at the expense of individual death.

These theories are not mutually exclusive. The maximum life span may be a programmed phenomenon which is shortened to the actual life span by environmental factors or random genetic events reducing the cells' capacity to survive.

3. Acute inflammation

'The reaction of vascularized living tissue to local injury'

BASIC COMPONENTS

1. Changes in the microcirculation
2. Formation of a fluid exudate
3. Formation of a cellular exudate

1. Changes in the microcirculation

Changes in calibre

- (i) Transient arteriolar constriction as a direct response to the injurious agent
- (ii) Persistent vasodilatation of arterioles, venules, and lymphatics, and an opening up of 'dormant' parts of the capillary network - active hyperaemia

Changes in flow

- (i) Initially rapid as a result of vasodilatation
- (ii) Slowing with disturbance of axial flow as a result of increased blood viscosity secondary to loss of plasma through the vessel wall

2. Formation of a fluid exudate

Normally the walls of small blood vessels are freely permeable to water and crystalloids but most of the plasma proteins are retained, i.e. there is 'molecular sieving'.

Normal fluid transport may be via:

- (i) Micropinocytosis - transfer of plasma across the endothelial cell within vesicles
- (ii) Intermittent opening of inter-endothelial cell junctions
- (iii) 'Closed' inter-endothelial junctions

The quantitative importance of these various routes is not known. Micropinocytosis and transient opening of junctions would permit the passage of plasma including high molecular weight proteins across the endothelium, so that molecular sieving would have to occur at the basement membrane. This membrane, however, is freely permeable to large molecules so these mechanisms cannot explain the low protein fluid output of normal vessels. On the other hand, normal ('closed') inter-endothelial cell junctions allow the passage of water, crystalloids and low molecular weight proteins, so that this mechanism adequately accounts for molecular sieving.

The formation of a protein-rich fluid exudate in inflammation is facilitated by separation of the intercellular junctions of the endothelium. Such separation, which is maximal in post-capillary venules, increases vascular permeability for higher molecular weight proteins such as fibrinogen and immunoglobulins. Gap formation between endothelial cells is a consequence of:

- (i) Direct injury

Lethal - resulting in the desquamation of dead cells and production of defects in the endothelial

lining

- b. Sub-lethal - causing cells to 'round-up' and separate
- (ii) Contraction of microfilaments under the influence of chemical mediators of inflammation

The fluid exudate carries into the inflamed tissue the following important constituents of the plasma:

- (i) Components of the complement system
- (ii) Specific antibodies which can act by coating bacteria prior to phagocytosis, or by neutralising exotoxins
- (iii) Circulating cytokines e.g. interleukin-1
- (iv) Acute phase proteins of which the principal member is fibrinogen. Once in the interstitium fibrinogen is converted to fibrin. Fibrin is important as a:
 - a. Cement substance uniting severed tissues
 - b. Scaffold for repair processes
 - c. Barrier against the spread of organisms
 - d. Surface against which the phagocytosis of microorganisms is enhanced - contact phagocytosis
- (v) Therapeutic agents-antibiotics, anti-inflammatory drugs, etc.

In addition, the increased fluid transit through the inflamed part has a beneficial dilutional effect on toxin and metabolite accumulation.

3. Formation of a cellular exudate

Following the phase of increased vascular permeability, leucocytes migrate through the walls of venules and appear in the interstitium. It was formerly believed that the leucocytes utilised the enlarged gaps between endothelial-cells to facilitate emigration, but recent work has demonstrated that the phase of increased permeability may be finished before migration begins. It is now thought that polymorphs (the first cells to appear) themselves open-up the gaps by inserting a cytoplasmic projection or pseudopodium into the junction. After the cell has passed through, the junction immediately closes and prevents further escape of plasma. The exudation of polymorphs is followed by monocyte emigration which may take 6-12 hrs to reach maximal levels. By this time the rate of polymorph accumulation is declining in a non-pyogenic inflammatory response.

Polymorph emigration can be divided into two main phases, adhesion and penetration:

- (i) Adhesion between polymorphs and endothelial cells. The mechanisms underlying adhesion are much more related to changes in the endothelial cell than to alterations in polymorphs and this explains the localised nature of polymorph margination and adhesion.

The mechanisms underlying polymorph adhesion are:

- a. Synthesis of adhesion molecules by endothelial cells which bind to specific receptors on the polymorph, e.g. ELAM-1 (endothelial leucocyte adhesion molecule), and ICAM-1 (intercellular adhesion molecule)

- b. Production of platelet activating factor (PAF) by endothelial cells may promote rapid adhesion, i.e. in the first few minutes following injury

- c. Complement activation leads to the deposition of C3b on the endothelial cell and serves as a bridge with the C3b receptor on polymorphs

Induction of adhesion molecule synthesis is brought about by:

- a. Cytokines, such as tumour necrosis factor (TNF) and interleukin 1 (IL-1)
- b. Bacterial endotoxins
- (ii) Penetration of the vessel wall by polymorphs involves:
 - a. Opening up of gaps between endothelial cells by insertion of a 'pseudopodium'
 - b. Migration into the subendothelial space under the influence of cytokines, TNF, IL-1 and chemotactic agents
 - c. Passage through the vascular basement membrane following its physical disruption. How the polymorph achieves this disruption is not known

MEDIATORS OF INFLAMMATION

The endogenous mediators of inflammation are derived either from plasma constituents or from cells.

Plasma-derived mediators

- A. The complement system
- B. The kinin system
- C. The coagulation-fibrinolysis system

Cell-derived mediators

- A. Vasoactive amines
- B. Acidic lipid products
- C. Lysosomal products
- D. Cytokines

PLASMA-DERIVED MEDIATORS

A. The complement system

Complement is the main effector pathway of the humoral immune response and results in

- (i) cytolysis
- (ii) the production of biologically active products which increase vascular permeability and enhance leucocyte migration and phagocytosis
- (iii) involvement of the coagulation and fibrinolytic systems

1. The classical pathway

Activation initiates a sequence of cleavage reactions each of which produces an enzyme responsible

for the next step in the cascade. In this way considerable amplification of the response is achieved. The major components are identified as C1-C9 whilst their cleavage products carry a lower case suffix. The high molecular weight products are usually designated 'b', e.g. C3b, whilst the minor fragments are designated 'a'. (C2b is an exception being of low molecular weight.) Activated components are identified by a bar over the numbers.

There are 11 proteins in the classical pathway, C1 having three main components, C1q, C1r and C1s, held together by calcium ions.

Activation may be triggered by a number of agents, the most important of which are complexes of IgG and IgM with antigen. The antigen is usually a cell or bacterial wall with antibodies attached by their Fab sites. C1q combines with their Fc regions and activates C1r which cleaves a peptide from C1s. The activated C1s acts as an esterase on C4 and C2 and the major products C4b and C2a remain attached to the cell membrane where they act in combination as the classical C3 convertase. C4b2a acts on several C3 molecules releasing the anaphylatoxin C3a into the fluid phase. The major product C3b combines with C4b2a and the enlarged complex then cleaves C5 releasing a second anaphylatoxin C5a. Without further enzymatic action C5b binds C6 and C7, and this complex binds C8 and six or more C9 molecules to form the final membrane attack unit.

2. The alternate pathway

Complement can also be activated at the C3 level without prior involvement of C1, C4 and C2. Activation of an initiating factor (IF) in conjunction with C3 triggers the alternate pathway. The most important activators are bacterial lipopolysaccharides (endotoxins) and aggregated IgA, IgE and IgG4. Activated IF binds to a site on the bacterial wall and reacts with activated Factor B (C3 activator) and native C3 to form an enzyme with limited C3 convertase activity. This acts on more C3, releasing C3a into the fluid phase and depositing C3b at further sites on the cell membrane. The C3b combines with activated B to form a complex which has labile C3 convertase activity. In this way more C3b is generated and by further combinations with B can greatly multiply the number of cell-bound C3bB complexes. This is the amplification feed-back loop. These complexes bind properdin (P) to form stable C3 and C5 convertases, the latter activity initiating the final membrane-attack sequence as in the classical pathway.

Activities of the complement system

Cytolysis

1. The C8 component of the final membrane attack complex C5-9 is thought to be responsible for cytolysis. It may act by an enzymatic (phospholipase) action or create defects by insertion of the protein complex into the membrane.

2. Anaphylatoxins

C3a and C5a bring about histamine release from mast cells and platelets.

3. Chemotaxins

C5a and C567 have a chemotactic effect on polymorphs, eosinophils and monocytes.

4. Immune adherence

C3b molecules opsonise bacteria and cell membranes permitting adhesion to polymorphs and macrophages via their C3b receptor sites. This ligand function, referred to as immune adherence

may:

- (i) facilitate phagocytosis
 - (ii) facilitate polymorph adhesion to endothelial cells prior to expression of adhesion molecules
 - (iii) bring about destruction of the C3b-coated target cell by release of cytotoxic enzymes
 - (iv) hold antigenic material and immune complexes on antigen presenting cells
 - (v) increase the solubility of immune complexes by disrupting their lattice structure
5. Kinin activity

C2b displays kinin-like activity in directly increasing vascular permeability

6. Blood coagulation

Platelet aggregation by C3b and lysis of platelets, together with activation of Factor XII by C567 initiate blood coagulation

The control of complement activation

1. Spatial control by membrane binding
2. Spontaneous decay, e.g. of C3 and C5 convertase
3. Specific inhibitors exert a modifying effect at many points in the pathway. Examples are:
 - (i) C1 esterase inhibitor
 - (ii) C3b inactivator which is important in controlling the amplification loop
 - (iii) Carboxypeptidase B which inhibits the anaphylatoxins C3a and C5a

B. The kinin system

The kinins are polypeptides composed of 8-10 amino-acids and are present in the plasma globulin fraction as inactive precursors kininogens. These precursors are activated by widely distributed plasma and tissue enzymes, kininogenases. The major plasma enzyme with this property is kallikrein which itself is generated by the action of either activated Factor XII (Hageman factor) or plasmin on prekallikrein.

Factor XII is activated by:

1. Contact with negatively charged surfaces including exposed collagen
2. Antigen-antibody complexes
3. Bacteria[endotoxins
4. Polymorph lysosomal enzymes

The major kinins are bradykinin (amino acids) and kallidin (10 amino acids, lysyl-bradykinin), and both cause:

1. Vasodilatation
2. Increased vascular permeability
3. Stimulation of pain receptors

C. The coagulation-fibrinolysis system

Activation of Factor XII also initiates the blood clotting cascade so that coagulation and fibrinolysis are intimately connected with the acute inflammatory response. The principal mediator is plasmin which is formed by the action of kallikrein on plasminogen. The main actions of plasmin are:

1. Breakdown of fibrin to fibrinopeptides - fibrin degradation products (FDPs). These products directly increase vascular permeability and are chemotactic for polymorphs
2. Converts kininogens into kinins
3. Converts prekallikrein to kallikrein
4. Acts on C3 to initiate the alternate pathway

CELL-DERIVED MEDIATORS

A. Vasoactive amines

1. Histamine

This is the best documented of the chemical mediators and is widely distributed through the tissues. Histamine is formed by the action of the enzyme histidine decarboxylase on the amino acid histidine. The most important source of histamine is from the degradation of mast-cells.

Degranulation is provoked by:

- (i) Antigen interaction with cell-bound IgE antibodies
- (ii) Anaphylatoxins (C3a, C5a)
- (iii) Cytolysis by the full complement pathway
- (iv) Direct injury

Histamine release causes arteriolar dilatation, constriction of veins, and increased vascular permeability of short duration (10-15 min).

2. 5-Hydroxytryptamine (serotonin, 5HT)

This amine is also present in mast-cells together with platelets and enterochromaffin cells. 5HT is a potent vasoconstrictor and is relatively more active on the smooth muscle of veins than of arterioles and so produces a rise in capillary pressure. However it does not increase vascular permeability and its role in the acute phase of inflammation is questionable.

B. Eicosanoids (acidic lipid products)

This group consists of long-chain fatty acid derivatives of the ubiquitous 20-carbon parent compound arachidonic acid. Arachidonic acid is a major constituent of the phospholipids of plasma membranes and is readily released for further metabolism by the enzyme phospholipase A2. The products can be allocated to two main groupings depending upon the initial enzymic pathway, the cyclo-oxygenase products are the Prostaglandins and the lipoxygenase products are the hydroperoxy fatty acids, notably the leukotrienes but also including long-chain hydroperoxides (HPETEs) and hydroxyacids (HETEs).

1. Prostaglandins

The 'classical' Prostaglandins involved in acute inflammation are E2, D2 and F2a, of which E2 is the

most potent. They cause vasodilatation and potentiate the increase in permeability brought about by histamine and bradykinin. Prostaglandins also manifest anti-inflammatory effects, however, and may suppress the release of polymorph lysosomal enzymes and mast-cell degranulation by raising intracellular cAMP levels. Two further cyclo-oxygenase products are prostacyclin (PGI₂), a potent vasodilator, and thromboxane A₂ (TxA₂) a vasoconstrictor antagonising the effects of prostacyclin and a powerful aggregator of platelets.

2. Leukotrienes

It is now clear that the chemical mediator long known as 'slow reacting substance' (SRS) is a mixture of leukotrienes - C₄, D₄, and E₄, and that these substances are responsible for the smooth muscle contraction and increased vascular permeability formerly attributed to SRS. Subsequently a more potent inflammatory mediator has been identified as leukotriene B₄ which has the following actions:

- (i) Chemotactic for polymorphs
- (ii) Enhances polymorph movement
- (iii) Causes degranulation of mast-cells
- (iv) Causes release of lysosomal enzymes

Enhances the increase in vascular permeability brought about by classical prostaglandins.

A major source of LTB₄ is synthesis by leucocytes including polymorphs, thereby amplifying polymorph exudation in an acute inflammatory reaction.

C. Platelet Activating Factor

PAF is a potent vascular permeability factor produced by degranulating mast cells which causes aggregation of platelets and release of histamine and 5HT. Other cell types are capable of synthesising PAF including neutrophils, macrophages and endothelial cells and in addition to its permeability effects PAF increases polymorph adhesion to endothelial cells and is chemotactic for polymorphs. PAF also stimulates the production of other inflammatory mediators such as Prostaglandins and leukotrienes.

D. Lysosomal products

A wide variety of lysosomal products (mainly enzymes) are released by polymorphs, and to a lesser extent by monocytes, in acute inflammation. These include:

1. Cationic proteins capable of:
 - (i) Degranulating mast-cells
 - (ii) Increasing vascular permeability independent of mast-cells
 - (iii) Chemotactic effects on monocytes
2. Proteases
 - (i) Leucokinogenase, an acid protease which acts on plasma precursors to produce leukokinins
 - (ii) C5-cleaving enzyme which releases the anaphylatoxin C5a

- (iii) Plasminogen activator

E. Cytokines

Lymphocyte and macrophage products which have a role in acute inflammation include:

- (i) Granulocyte-macrophage colony stimulating factor (GM-CSF) increases the production of polymorphs
- (ii) Interleukin-1 promotes leucocyte-endothelial adhesion and activates eosinophils and basophils
- (iii) Interleukin-8 is chemotactic for polymorphs
- (iv) Tumour necrosis factor (TNF) increases expression of endothelial adhesion molecules and enhances polymorph chemotaxis and phagocytosis

THE ROLE OF MEDIATORS IN VASCULAR PERMEABILITY

The early increase in vascular permeability is brought about by histamine released by mast-cells activated by C3a, C5a and PAF, probably aided by bradykinin. Plasma leakage may be potentiated by increased blood flow induced by vasodilator Prostaglandins. Lipo-oxygenase products are likely to be important in sustaining vascular permeability; in particular LTC4 and D4 are potent inducers of macromolecular leakage from post-capillary venules. Likewise, in combination with vasodilator Prostaglandins, LTB4 potentiates plasma leakage.

ACTIVITIES OF THE NEUTROPHIL POLYMORPH

A. Movement

Polymorphs move by amoeboid motion brought about by contractile forces provided by a network of microfilaments. The network is made up of actin, actin-binding protein, and myosin. Microtubules also play some part and probably translate membrane signals into the correct locomotory response (sensory transduction). Energy for movement and ingestion is provided by ATP generated by anaerobic glycolysis.

Polymorph movement can be:

1. Enhanced by chemokinetic factors such as leukotriene B4
2. Directed by chemotactic factors which the cell detects as a concentration gradient over its membrane

A wide variety of chemotactic factors have been described but the number of receptors on the neutrophil is likely to be small. It is possible, therefore, that many chemotaxins act on a common receptor or induce chemotaxis indirectly by stimulating cells to produce a common chemotactic factor.

Chemotactic factors

1. Plasma derived
 - (i) Complement products

- a. C5a
 - b. C5a des arg (C5a minus the terminal arginine) is chemotactic in the presence of a serum 'helper factor'
 - c. C567
- (ii) Kinin system Kallikrein
- (iii) Fibrinolytic system

Fibrin degradation products - fibrinopeptide B

Thrombin

2. Cell derived
 - (i) Leukotrienes, especially LTB4
 - (ii) Neutrophil chemotactic factor (NCF) produced by activated macrophages
 - (iii) Platelet activating factor (PAF)
 - (iv) Cytokines, e.g. interleukin-8, TNF
3. Bacterial factors
 - (i) Soluble, low molecular weight (<3600) bacterial peptides, e.g. f-Met-Leu-Phe
 - (ii) Proteases which cleave C5
4. Tissue breakdown products

Tissue injury results in the partial digestion of collagen, elastic and other proteins. The resulting protein fragments are directly chemotactic for polymorphs

B. Phagocytosis

Polymorphs ingest bacteria or other particles by extending pseudopodia around them. Subsequent fusion of these processes encloses the bacterium in a heterophagic vacuole formed by the internalised plasmalemma. Adhesion of micro-organisms to polymorphs is facilitated by opsonisation - coating of the organism with immunoglobulin or complement products which can then attach to the Fab or C3b receptors on the polymorph surface membrane. The mode of opsonisation is related to the immune status:

1. Non-immune state The alternate pathway is activated by bacterial lipopolysaccharide and adhesion brought about by generation of C3b.
2. Normal immune state The classical pathway of complement is activated by specific antibody binding to bacterial antigen. Adherence by C3b and Fc receptors follows.
3. Hyper-immune state (that is following recent infection or immunisation). A high concentration of specific antibody (IgG and IgM) is present; the Fab portions attach to the surface antigen leaving the Fc terminals to attach to specific receptor sites on the neutrophil. This is complement independent opsonisation.

The intracellular events during phagocytosis include

1. Rise in oxygen consumption

2. Increased glycogenolysis
3. Increased glucose oxidation via the hexose-monophosphate shunt
4. Production of reactive oxygen metabolites

C. Intracellular microbial killing

Within the phagocytic vacuole, bacteria and other micro-organisms are attacked by several agents aimed at destruction of the organism. These agents or mechanisms may or may not involve oxygenation: the oxygen dependent mechanisms are the most important in achieving bacterial killing:

1. Oxygen dependent mechanisms

Hydrogen peroxide (produced via the hexose-monophosphate shunt) reacts with

myeloperoxidase to form a highly oxidative complex. This reacts with a co-factor such as halide ions or thiocyanates to form a strong antimicrobial agent

(ii) Highly reactive products of oxygen reduction may contribute to bacterial killing:

- a. Superoxide anion (O⁻²)
- b. Singlet oxygen (1O₂)

Hydroxy radicals (OH_·)

2. Oxygen independent mechanisms

- (i) Low intravacuolar pH resulting from lactic or carbonic acid formation
- (ii) Lactoferrin acts by chelating the iron required for bacterial growth
- (iii) Lysozyme (muramidase)
- (iv) Granular cationic proteins

D. Release of lysosomal products

Release of lysosomal products into the external medium:

1. Injure tissues by proteolysis - collagenase, elastase, cathepsins, etc. These enzymes are activated by oxidants escaping from polymorph granules, and are subsequently neutralized by antiproteases such as alpha-1-antitrypsin
2. Initiate blood coagulation by activating Factor XII
3. Increase vascular permeability - leucokinins
4. Attract other leucocytes

DISORDERS OF POLYMORPHS

A. Defective production (neutropenia)

1. Drug-induced neutropenia
2. Associated with aplastic anaemia
3. Associated with acute leukaemia

4. Associated with splenomegaly
5. Immune neutropenia resulting from
 - (i) Multiple blood transfusions (anti-leucocyte antibodies)
 - (ii) Passive maternal antibodies in neonates
 - (iii) Auto-immune reactions in SLE, rheumatoid disease, etc.
6. Chronic infantile agranulocytosis
7. Chronic idiopathic neutropenia
8. Associated with thymic aplasia or dysgammaglobulinaemia
9. Associated with exocrine pancreatic insufficiency (Schwachman's syndrome)

B. Defective chemotaxis

1. Abnormalities of adhesion molecules

Inherited deficiency of leucocyte adhesion proteins

2. Abnormalities of chemotactic factors

- (i) Decreased production, e.g. deficient complement components C3, C5
- (ii) Inhibition of chemotactic factor formation and action, e.g. in uraemia, hepatic failure
- (iii) Circulating chemotactic factor inactivator in Hodgkin's disease

3. Cellular defects

- (i) Abnormal polymorph adherence, e.g. in steroid therapy, diabetes and acute alcohol intoxication
- (ii) Abnormal deformability, e.g. Chediak-Higashi disease an autosomal recessive condition characterised by partial albinism and recurrent pyogenic bacteria[infections, possibly resulting from abnormal cyclic GMP metabolism and faulty microtubule assembly
- (iii) Abnormal random migration -'lazy leucocyte syndrome' possibly related to defective polymerisation of actin in the microfilaments
- (iv) Abnormal directed migration in response to chemotaxins

C. Defective phagocytosis

1. Disorders of opsonisation

- (i) C3 deficiency
- (ii) Low IgM, e.g. in neonate, hypogammaglobulinaemia

2. Diminished ingestion

Immaturity of neutrophils, e.g. in acute leukaemia

D. Defects in bactericidal activity

1. Disorders of granules

- (i) Chediak-Higashi disease, in which giant lysosomes fail to fuse with the phagosome

- (ii) Deficiency of lysozyme and secondary granules
- 2. Defective microbial killing
 - (i) Chronic granulomatous disease which results from a failure to produce hydrogen peroxide, due to a deficiency of NADH oxidase
 - (ii) Myeloperoxidase deficiency
- a. familial
- b. secondary to acute myeloid leukaemia
- (iii) Severe glucose-6-phosphate dehydrogenase deficiency
- (iv) Inhibition of the hexose-monophosphate shunt by a serum factor in hepatic failure

VARIETIES OF ACUTE INFLAMMATION

The general response to injury is modified according to the tissue and the nature of the injurious agent resulting in several descriptive types of inflammation.

1. Serous. formation of a protein-rich fluid exudate with minor cellular exudation, e.g. synovitis, peritonitis
2. Fibrinous: exudate contains abundant fibrinogen which is precipitated as a thick fibrin coating, e.g. pericarditis
3. Haemorrhagic: inflammation associated with conspicuous haemorrhage as a result of vascular damage, e.g. meningococcaemia, viral pneumonia
4. Suppurative (or purulent) - characterised by the production of pus composed of:
 - (i) Dead and dying polymorphs
 - (ii) Liquefied tissue
 - (iii) Pyogenic organisms

Suppuration may result in the formation of:

- (i) Abscess - a localised collection of pus in an organ or tissue
- (ii) Empyema - a collection of pus in a hollow viscus, e.g. in the gall-bladder or appendix, or a body space, e.g. empyema thoracis in the pleural space
5. Membranous: inflammation of a lining epithelium with a coating of fibrinous exudate, more or less intact sheets of detached epithelium, and inflammatory cells
6. Pseudo-membranous: the adherent coat is composed of matted fibrin and inflammatory cells and is usually associated with only focal superficial ulceration, e.g. pseudomembranous colitis
7. Catarrhal. inflammation of mucosal surfaces with hypersecretion of mucus, e.g. common cold

Necrotising or gangrenous: acute inflammation associated with widespread necrosis of the organ probably resulting from superimposed thrombosis or vascular occlusion due to high tissue pressure, e.g. in severe acute appendicitis



Low Body Voltage leads to weak membrane potential, weak osmosis, trapped toxins, premature aging, and increased susceptibility to virus

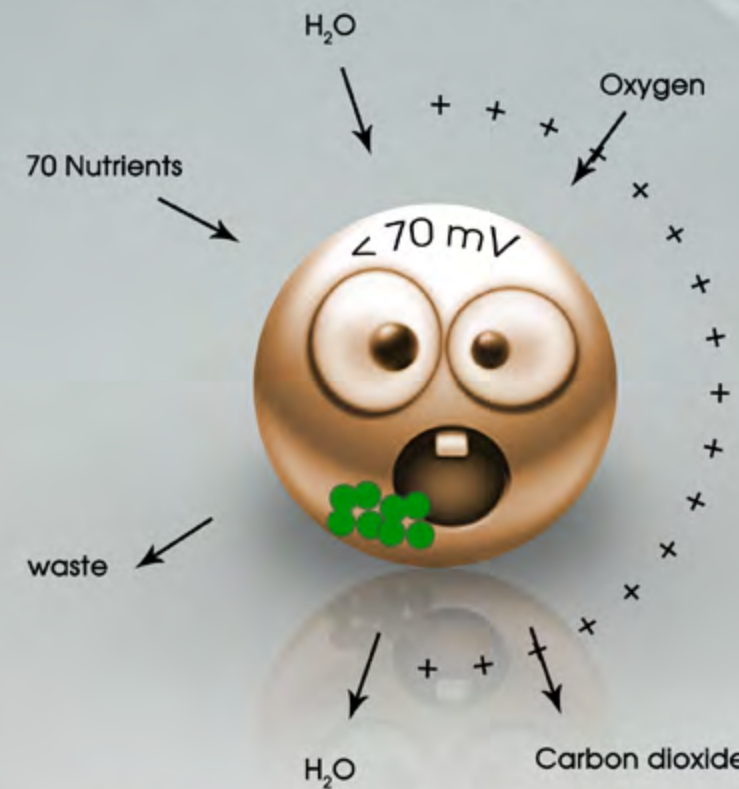

Charging the Human Battery

Factors that influence the body voltage and membrane potential are fatty acids in the cell membrane, minerals, especially salts, hydration water, oxygenation, stress, toxins and life style.

The SCIO has been proven in tests to increase the electrical potential of the body. Increased cellular membrane potential makes osmosis increase, which increases detoxification, nutrient transfer and absorption, hydration, oxidation, and all cellular functions in general.

Healthy membrane potential and adequate body voltage makes all of the functions of the cell work better



If you need more information on the SCIO and purchase details please get in touch with us

Maitreya Kft.

tel: +3613036043 | web: www.qxsubspace.com | e-mail: info@qxsubspace.com



OUTCOME OF ACUTE INFLAMMATION

1. Resolution. The inflammatory exudate is reabsorbed and the tissue restored to normal, e.g. lobar pneumonia. This presumes that there has been no tissue destruction.
2. Healing by repair or regeneration where tissue has been destroyed.
3. Chronic inflammation. Continuing acute inflammation with attempts at healing.
4. Spread
 - (i) Direct - e.g. cellulitis
 - (ii) Lymphatic - lymphangitis progressing to acute lymphadenitis
 - (iii) Blood vessels
 - a. Pyaemia - spread of pyogenic organisms in infected micro-thrombi via the blood stream possibly giving rise to secondary (metastatic) abscesses.
 - b. Septicaemia – multiplication of organisms in the blood stream in the absence of adequate host defences
5. Death resulting from
 - (i) Toxaemia, e.g. endotoxic shock and its complicationsInvolvement of vital organs, e.g. encephalitis, myocarditis

4. Healing

Healing is the body's replacement of destroyed or lost tissue by viable tissue.

Tissue replacement is achieved in two ways:

Regeneration. The proliferation and migration of specialised cells re-establishing the anatomical and functional integrity of an organ or tissue.

Repair. The proliferation and migration of connective tissue cells leading to fibrosis and 'scar' formation.

As cellular proliferation is an essential component of repair, there is considerable overlap between the processes of regeneration and repair.

MAJOR CAUSES OF TISSUE DESTRUCTION

1. Loss of blood supply - ischaemic necrosis, e.g. myocardial infarction
2. Inflammatory agents
 - (i) By direct physical or toxic effects, e.g. an abscess
 - (ii) Indirectly as a result of the host response, e.g. caseous necrosis in tuberculosis
3. Traumatic excision
 - (i) Accidental
 - (ii) Surgical

4. Radiotherapy

REGENERATION

The capacity of damaged tissue to respond by regeneration varies considerably. Tissues can be allocated to one of three categories:

1. Labile cells which continue to proliferate throughout life, e.g. epidermis, lining epithelia, endothelium, connective tissue, haemopoietic tissue
2. Stable cells which retain the capacity to regenerate and occasionally exhibit mitoses by virtue of normal cell-turnover, e.g. liver, renal tubular epithelium, smooth muscle
3. Permanent cells which cannot reproduce themselves after attaining maturity, e.g. neurones of the CNS, sensory organs, renal glomeruli, striated muscle, adrenal medulla

Following injury labile tissues heal by regeneration with little or no repair. Permanent tissues are incapable of regeneration and heal entirely by repair. Most organs show evidence of both processes.

Control of regeneration

Regeneration appears to be controlled by the balance between stimulators and inhibitory growth factors or hormones. Stimulation appears to be a two-stage process:

1. Priming. Cells in G1 or growth arrested cells in G0 are primed for progression to cell division. An example of this type of factor is platelet derived growth factor (PDGF) which is released following activation of platelets but is also produced by endothelial cells and macrophages. PDGF initiates the proliferation of fibroblasts and smooth muscle cells.
2. Progression. Once primed, the cells are acted upon by other growth factors which stimulate DNA synthesis. These potentiating factors include epidermal, fibroblast and transforming growth factors (EGF, FGF, and TGF α)

Cell proliferation is also under the influence of general or nonspecific stimulators like growth hormone, and insulin-like growth factor.

Fibroblasts are also stimulated to divide by interleukin-1 and tumour necrosis factor which also up-regulates collagen synthesis. Inhibition of cell division is less clearly understood. TGF β is known to act as an inhibitor under certain circumstances, and Prostaglandins and α -interferon are known to inhibit fibroblasts in vitro.

REPAIR

Injury to tissues is followed by extravasation of blood and a complex series of reactions embracing the coagulation, complement and kinin systems. Endothelial damage results in leakage of platelets into the interstitium where they release PDGF and other growth factors from their granules. PDGF initiates fibroblast replication which is the predominant feature of early repair.

Repair involves two overlapping processes:

1. Organisation
2. Progressive fibrosis

1. Organisation

This is the conversion of dead tissue or inert material into granulation tissue - immature fibrovascular tissue. Organisation is seen in:

- (i) Haematomas in wound and fracture healing
- (ii) Thrombi
- (iii) Infarcts
- (iv) Fibrinous exudates

Granulation tissue forms by:

(i) Demolition. Monocytes migrate into the area, take on the properties of macrophages, and phagocytose cell debris, fibrin and red blood cells. Clearance of dead tissue is facilitated by the secretion of proteolytic enzymes by macrophages (e.g. collagenase, elastase) and other secretory products are important in promoting repair, e.g. interleukin-1

(ii) Fibroblast activity. Local resting fibroblasts (fibrocytes) proliferate rapidly and migrate into the area where they continue to divide and commence synthetic activity. Initially the activated fibroblasts produce proteoglycans but as they mature switch over to collagen synthesis. At the same time, some fibroblasts develop bundles of microfilaments in their cytoplasm and acquire contractile properties. Such modified fibroblasts are termed myofibroblasts.

(iii) Ingrowth of capillaries. Endothelial cells in the severed blood vessels of surrounding viable tissue undergo rapid proliferation and grow into the area as solid cords. Angiogenesis is stimulated by TGF α and basic FGF which is stored extracellularly bound to heparin sulphate on the cell surface and in the matrix. The proliferating endothelial cells form 'buds' which:

- a. Link up to form arcades
- b. Canalise. This occurs within hours of formation
- c. Become freely permeable to plasma, RBCs, leucocytes and platelets
- d. Differentiate into arterioles, capillaries and venules

2. Progressive fibrosis

- (i) Continued accumulation of intercellular collagen
- (ii) Collagen re-orientation along lines of stress - remodelling
- (iii) Diminished cellularity
- (iv) Formation of an avascular, hypocellular 'scar'

Further changes in scars:

- (i) Cicatrization - a late diminution in size resulting in deformity
- (ii) Calcification
- (iii) Ossification

CELL-MATRIX INTERACTIONS

The matrix of repair tissue consists predominantly of collagen and proteoglycans. The proteoglycans or 'ground substance' of connective tissues are, as their name implies, macromolecules composed of a protein core to which carbohydrate is attached. The carbohydrate moieties take the form of long linear polysaccharides which are attached radially around the protein molecule. They can be divided into sulphated and non-sulphated types:

Sulphated:

- Heparan sulphate
- Keratan sulphate
- Chondroitin sulphates A, B, and C

Non-sulphated:

- Hyaluronic acid
- Chondroitin

The protein moiety is synthesised in the rough ER of the fibroblast and to this core the hexose sugars are sequentially added to form the polysaccharide attachments. Sulphation follows as a separate step.

Collagen is the most abundant protein in the body and forms the major structural component of many organs. Collagen molecules consist of three polypeptide chains arranged in a triple helix and whilst the basic polypeptide structure is straightforward, the molecule undergoes a complex series of post-translational modifications and interactions with proteoglycans which greatly modifies its properties. On the basis of the differing composition and combinations of its constituent chains, eleven types of collagen have been recognized thus far; Types I, II and III are fibrillar collagens while Types IV to XI are amorphous forms found in basement membranes or in the interstitium.

Collagen type

Tissue distribution

I	All connective tissues (bone, dermis, tendon, cornea)
II	All cartilages, nucleus pulposus, eye
III	Reticulin fibres, early scar tissue, fetal and infant connective tissue
IV	Basement membranes (epithelial and endothelial)
V-XI	Interstitial tissues and blood vessels

Whilst it has long been appreciated that certain cells require to be attached to substrate before they can proliferate normally, it has only recently been established that such attachment is brought about by a series of specific binding proteins. These proteins are particularly important in the proliferation of connective tissue cells:

1. Fibronectin attaches fibroblasts to collagen
2. Chondronectin binds chondrocytes to Type II collagen, the matrix of cartilage
3. Laminin binds epithelial cells to the Type IV collagen of basement membranes. Specific receptors (integrins) link the binding proteins to the appropriate cell type and form a molecular

bridge between the cell and the matrix

4. Osteonectin binds hydroxy-apatite and calcium ions to Type I collagen (bone matrix) and initiates mineralisation

WOUND HEALING

In considering the healing of a skin wound two types are usually distinguished:

1. A clean wound with closely apposed margins - an incised wound
2. An open or excised wound

There are no fundamental differences between these two types, they merely differ in the degree to which the various stages apply.

Stages in wound healing

1. Escape of blood and exudate
2. Acute inflammatory response at the margins
3. Hardening of the surface forming a scab
4. Demolition by macrophages with phagocytosis of cellular debris and secretion of proteolytic enzymes which assist in the removal of dead tissue, for example collagenases and elastase. In addition macrophages secrete products which are important in the early stages of repair such as interleukin-1 and fibronectin.
5. Platelets escaping from the severed vessels release PDGF, EGF, TGF α and other growth factors
6. Organisation:
 - (i) PDGF initiates fibroblastic proliferation
 - (ii) Activated fibroblasts secrete proteoglycans
 - (iii) Fibroblasts produce Type III collagen (reticulin) fibres and migrate along this 'scaffold'
 - (iv) Fibronectin-mediated attachment of fibroblasts to collagen is followed by enhanced proliferation
 - (v) Simultaneous proliferation and migration of endothelial cells
7. Contraction of the wound - an early diminution in size brought about by the inward movement of the skin margins which greatly reduces the volume of repair tissue required for healing. Such contraction is attributed to the activity of myofibroblasts and to resorption of proteoglycans
8. Epidermal proliferation. By mitotic activity and migration, epidermal cells grow in from the margins and undermine the surface scab. When they meet in the centre of the wound, mitosis and migration cease presumably as a result of some cell-to-cell signal. This phenomenon is known as 'contact inhibition'. The factors controlling epidermal proliferation are not fully understood, but the following mechanisms have been proposed:
 - (i) Tissue injury brings about the production and release of epidermal growth factor (EGF). EGF stimulates replication until regeneration is complete at which point synthesis is curtailed.

- (ii) Injury depletes the local concentration of an inhibitory factor, possibly TGF β , which removes its negative influence on mitosis. As the wound heals, levels of such factors build up and mitotic activity subsides to the pre-injury state

9. Progressive increase in collagen fibres
10. Loss of vascularity and shrinkage of the scar

The healing of an excised wound differs from that of an incised wound in that there is:

1. Greater tissue loss
2. More inflammatory exudate and necrotic tissue to remove
3. Wound contraction is necessary
4. More granulation tissue is required, a bigger scar is formed and this may result in deformity
5. Slower process
6. Increased liability to infection

Factors influencing wound healing

1. Local factors adversely affecting healing
 - (i) Type of wounding agent; blunt, crushing, tearing, etc.
 - (ii) Infection
 - (iii) Foreign bodies in wound
 - (iv) Poor blood supply
 - (v) Excessive movement
 - (vi) Poor apposition of margins, e.g. large haematoma formation
 - (vii) Poor wound contraction due to tissue tethering, e.g. skin over tibia
 - (viii) Infiltration by tumour
 - (ix) Previous irradiation
 - (x) Tissue pressure
 - a. External, e.g. sacral bed sores
 - b. Intrinsic, e.g. lymphoedema
2. General factors adversely affecting healing
 - (i) Poor nutrition
 - a. Deficiency of protein. This results in a lack of the sulphur-containing amino acids methionine and cystine which are essential for the synthesis of collagen
 - b. Lack of ascorbic acid (vitamin C) results in abnormal granulation tissue and deficient collagen production
 - c. zinc deficiency
 - (ii) Excessive glucocorticosteroid production or administration

- (iii) Fall in temperature
- (iv) Jaundice
- (v) Old age
- 3. Factors accelerating wound healing
 - (i) Ultraviolet light
 - (ii) Administration of anabolic steroids, deoxycorticosterone acetate, and (?) growth hormone
 - (iii) Rise in temperature
 - (iv) Therapeutic administration of growth factors

Complications of wound healing

1. Wound rupture
2. Infection
3. Implantation of epidermal cells giving rise to keratin-filled epidermal cyst
4. Weak scars with possible development of incisional herniae
5. Cicatrisation and deformity
6. Keloid formation. The production of an elevated scar by excessive connective tissue proliferation and fibrosis
7. Malignant change. The development of squamous carcinoma in old healed incisions is a recognised but rare complication

HEALING OF A FRACTURE

Steps in the healing of a fractured long bone are:

1. Haemorrhage from the highly vascular severed ends producing a large haematoma
2. Inflammation - an acute inflammatory response to injury
3. Organisation - the haematoma is infiltrated by fibroblasts and endothelial cells. At the same time demolition by macrophages assists in the partial reabsorption of blood clot and cell debris.
4. Proliferation of specialised cells - cells derived from the periosteum and the severed ends of the endosteum secrete proteoglycans (like fibroblasts in general matrix special form of collagen (Type I) that provides the bone matrix - so-called osteoid. These specialised connective tissue cells are osteoblasts.
5. Mineralisation - the Type I collagen fibres of the osteoid bind the attachment protein osteonectin which sequesters calcium and phosphate ions out of solution. In this way calcium phosphate precipitates on the fibres and after one or more intermediate phases, hydroxy-apatite crystals are formed at discrete sites. Subsequently the secondary processes of crystal-growth and seeding of other crystals by the original deposits extend the area of mineralisation over the fibres. The result of mineralisation of the irregularly arranged collagen fibres of osteoid is woven bone. By this stage the fractured ends of the bone are united by a hard fusiform mass of granulation

tissue and woven bone - this is fracture callus. Where there is excessive movement, e.g. in a rib fracture, or there is a relative lack of nutrients, as for example at the centre of a large haematoma, the connective tissue cells differentiate into chondroblasts. These cells produce large amounts of proteoglycans and synthesise Type II collagen fibres which in combination make up cartilage. The cartilage also becomes calcified.

6. Conversion to lamellar bone - the woven bone, and any calcified cartilage present, undergoes phagocytic resorption by multinucleate osteoclasts. At the same time osteoblasts lay down regular Type I collagen plates with Haversian systems which on mineralisation forms lamellar bone
7. Remodelling of lamellar bone - continuing osteoclastic and osteoblastic activity over many months brings about remodelling of the bone. Remodelling is a complex process regulated by hormones and growth factors. Most of the local growth factors are common to those which regulate wound healing. Thus interleukin-1, TNF α , PDGF and lymphocyte-derived interferon- γ , all play a part. There are however, additional factors derived from skeletal cells and the bone matrix; these include TGF- β , basic FGF and somatomedin C. The final contour of the bone appears to be dictated by the lines of stress set up within it on mobilisation.

Complications of fracture healing

1. Delayed union
2. Mal-union
 - (i) Angulation
 - (ii) Shortening
3. Fibrous union resulting from
 - (i) Excessive movement which may lead to the development of a false joint (pseudoarthrosis)
 - (ii) Infection which may also give rise to osteomyelitis
 - (iii) Ischaemia
4. Non-union if soft-tissues such as muscle or fat are interposed between the severed ends

PATHOLOGICAL FRACTURES

These are fractures occurring spontaneously (that is with normal stresses) because of intrinsic disease of the bone.

Causes

1. Osteoporosis
2. Metastatic tumours
3. Primary tumours (benign and malignant)
4. Paget's disease
5. Bone lesions of hyperparathyroidism
6. Osteogenesis imperfecta

HEALING IN OTHER SITES

1. Liver

(i) After a single, short-lived injury such as drug-induced necrosis or acute hepatitis, the liver heals completely by regeneration

(ii) Repeated injury, as in alcoholic abuse or chronic hepatitis, leads to collapse of the reticulin framework, production of collagen by mesenchymal cells, and irregular, nodular regeneration, resulting in cirrhosis.

2. Kidney

Regeneration is virtually confined to the tubular epithelium and is seen for example after acute tubular necrosis. Otherwise injury results in loss of glomeruli and scarring.

3. Mucosal surfaces

(i) Superficial ulceration (erosion) is followed by regeneration of the epithelium but there may be loss of specialised cells. In the stomach, for example, healed areas may be covered by intestinal-type epithelium or show pseudo-pyloric metaplasia (ulcer-associated cell lineage). Deeper ulceration with involvement of submucosa and muscle heals by scar formation and epithelial regeneration

4. Nervous system

Adult neurones are incapable of mitotic division but limited regeneration is possible

(i) Peripheral nerve section results in distal Wallerian degeneration, growth of axon-sprouts from the cut end, and proliferation of Schwann cells, with eventual enclosure in a new myelin sheath

(ii) Central nervous system. If the involved neurone survives axons and dendrites can regrow, but most tissue loss is followed by astrocytic proliferation with the formation of a glial scar often around a fluid filled cavity

5. Muscle

(i) Cardiac muscle shows no regeneration and healing is achieved entirely by fibrous repair

(ii) Skeletal muscle shows a limited capacity to regenerate and if only part of a muscle fibre is destroyed then the fibre may regrow within the sarcolemmal sheath

(iii) Smooth muscle cells are capable of proliferation and minor tissue loss may be followed by successful regeneration

5. Chronic inflammation

A process in which there is continuing inflammation at the same time as attempts at healing resulting from persistence of the injurious agent.'

Mechanisms

The injurious agent may persist because:

1. There is a defective acute inflammatory response

- (i) Poor blood supply
 - (ii) Poor general nutrition
 - (iii) Abnormal neutrophil function
 - (iv) Anti-inflammatory drugs, especially corticosteroids
2. The agent is resistant to phagocytosis and/or intracellular destruction
 - (i) Intracellular infectious agents, e.g. tuberculosis, salmonellosis, brucellosis, viral infections

Foreign-body reactions. These act as a nidus for persistent infection or as tissue irritants which directly provoke a chronic inflammatory reaction.

Such irritants can be divided into:

Endogenous, e.g. necrotic adipose tissue, cholesterol crystals, uric acid crystals in gout

b. Exogenous, e.g. suture material, metallic fragments, silica, asbestos fibres

3. The provoking agent is a body constituent as in:

- (i) Auto-immune diseases, e.g. diffuse lymphocytic thyroiditis (Hashimoto's disease), auto-immune atrophic gastritis, adrenal atrophy, etc.
- (ii) Reactions to altered self-antigens, e.g. contact dermatitis to rubber, nickel, etc.

CLASSIFICATION

1. Clinical

- (i) Following a recognisable acute inflammation, e.g. chronic osteomyelitis
- (ii) Arising de novo, e.g. brucellosis, tuberculosis

2. Histological

- (i) Specific - having a reproducible histological pattern, e.g. tuberculosis, syphilis, leprosy
- (ii) Non-specific - showing only the general features of inflammation, e.g. chronic cholecystitis, chronic pyelonephritis

GENERAL FEATURES

1. Continuing acute inflammation
 - (i) Polymorph infiltration
 - (ii) Fibrinous exudation
 - (iii) Increased vascularity
2. Features of healing - repair and/or regeneration
 3. Infiltration by chronic inflammatory cells
 - (i) Macrophages
 - (ii) Lymphocytes
 - (iii) Plasma cells

- (iv) Eosinophils

CELLS OF CHRONIC INFLAMMATION

A. Macrophages

Although monocyte emigration is a feature of the later stages of acute inflammation, their accumulation as macrophages in chronic inflammation is frequently conspicuous and they may constitute the predominant cell type. When macrophages are the dominant cell, and in particular when they are found in circumscribed aggregates, the inflammatory reaction is termed granulomatous. The aggregates themselves are termed granulomas.

Granulomas with a high turnover of cells recruit macrophages from the circulating monocyte 'pool'. The demands of low-turnover granulomas can be met by proliferation of local tissue macrophages.

1. The mononuclear-phagocyte system

A system composed of macrophages and their precursors.

2. Functions of the macrophage

(i) Phagocytosis

- a. Ingestion and destruction of bacteria (particularly after a lymphokine response)
- b. Removal of effete cells or necrotic cell debris
- c. Storage of irritant substances, e.g. carbon particles

(ii) Antigen handling

- a. Endocytosis and processing of antigen with production of polypeptide fragments which are expressed on the cell surface in conjunction with Class II major histocompatibility antigens
- b. Direct cell-to-cell binding with specifically sensitised lymphocytes

(iii) Enzyme production

- a. Neutral proteases
 - Collagenase
 - Elastase
 - Plasminogen activator
 - Angiotensin convertase
- b. Acid hydrolases
 - Lipases
 - Acid proteases
 - Ribonucleases
 - Phosphatases
 - Glycosidases

Sulphatases

- c. Lysozyme (anti-bacterial activity)

(iv) Synthesis of

- a. Complement components
- b. Arachidonic acid metabolites

Prostaglandins

Thromboxane

Leukotrienes

- c. Binding proteins

Fibronectin

Transferrin

Transcobalamin

- d. Enzyme inhibitors

Plasmin inhibitors

(α -2-macroglobulin

- (v) Soluble mediator (cytokine) production

- a. Interleukins-1, 6 and 8
- b. Tumour necrosis factor α
- c. Interferon α

3. Special forms of macrophage

(i) Epithelioid cells - enlarged macrophages with finely granular eosinophilic cytoplasm which have an increased secretory capacity and are found in tuberculosis, sarcoidosis, Crohn's granulomas, etc.

(ii) Siderophages - macrophages laden with haemosiderin and found in:

- a. Areas of haemorrhage
- b. Chronic venous congestion of the lung ('heart failure cells')
- c. Haemosiderosis

(iii) Melanophages - melanin-laden macrophages found in the interstices of a malignant melanoma, pigmented naevus, etc.

(iv) Lipophages - macrophages with 'ground-glass' cytoplasm after phagocytosis of:

- a. Altered fat, e.g. in traumatic fat necrosis
- b. Cholesterol, e.g. in atherosclerosis, cholesterosis of the gall-bladder, etc.

(v) Muciphages - macrophages which have ingested mucin following its release from damaged epithelium, e.g. in the lamina propria of the large intestine after an episode of inflammatory bowel

disease

4. Giant cells

In some circumstances macrophages fuse and give rise to multinucleate giant-cells:

- (i) Specific infections
 - a. Tuberculosis (Langhans giant-cells)
 - b. Syphilis
 - c. Fungal infections
- (ii) Foreign-body reactions
- (iii) Lipid phagocytosis (Touton giant-cells) in xanthogranuloma, fibro-histiocytoma, etc.
- (iv) 'Collagen' diseases
 - a. Rheumatic fever (Aschoff giant-cells)
 - b. Rheumatoid nodules
 - c. Giant-cell arteritis
- (v) Granulomatous diseases of unknown aetiology
 - a. Sarcoidosis
 - b. Crohn's disease
 - c. Wegener's granulomatosis

B. Lymphocytes and plasma cells

Small lymphocytes can be divided into two reactive populations

- (i) B-lymphocytes which are responsible for antibody mediated (humoral) immunity
- (ii) T-lymphocytes which are dependent upon the thymus for their proper development and are responsible for cell-mediated immune responses such as direct cytotoxicity, and also regulate antibody synthesis by B-lymphocytes

Following macrophage uptake and processing of antigens, polypeptide fragments are expressed at the cell surface and are recognized by either 'helper' T-lymphocytes or by 'cytotoxic' T-cells. The specific interaction with antigen leads to the synthesis and release of soluble growth and differentiation factors both by the antigen-presenting cells and the T-lymphocytes. The factors released by lymphocytes are termed lymphokines, and are responsible for the rapid proliferation and differentiation of the initially small population of antigen-specific lymphocytes present in the previously unchallenged host.

B-lymphocytes bear monomeric immunoglobulin (mIgM) on their surface which acts as the antigen receptor. B-cells may respond directly to some antigens, but the majority of antigen responses require the participation of helper T (TH) cells. Sensitized helper cells activate B-cells into the cell cycle and progressive multiplication ensues. At the same time genetic 'switching' leads to differentiation into a clone of plasma-cells producing an antibody identical to that present in monomeric form at the surface. At the same time a small population of primed 'memory' cells

equipped with the same immunoglobulin surface receptor are generated.

A third population of lymphocytes do not give conventional results in tests of T- and B-cells and these cells have been designated 'null cells'. This population also includes cells capable of antibody-dependent cytotoxicity (K cells), natural killer cells (NK cells) which spontaneously destroy tumour cells in vitro and lymphokine activated killer cells (LAK cells).

In the normal individual about 75% of the peripheral blood lymphocytes are T-cells. About 2/3 of these belong to the helper-inducer subset (CD4+), and the other 1/3 are of the cytotoxic or suppressor type (CD8+).

C. Eosinophils

Whilst eosinophils are seen in certain acute inflammatory responses such as atopic hypersensitivity reactions, they are more characteristic of chronic inflammation. They are poorly phagocytic cells whose granules have a high content of an arginine-rich cationic protein in addition to the usual granulocyte enzymes. They possess receptors for IgG, C3b and C3d.

1. Functions (possible)

- (i) Neutralisation of leukotrienes
- (ii) Inhibition of histamine release from mast-cells via the cyclic AMP system, probably by production of E1 and E2 Prostaglandins
- (iii) Production of enzymes capable of killing helminths
- (iv) Killing of antibody-coated cells

2. Chemotaxis

Eosinophils respond to the same chemotactic factors as neutrophil polymorphs with the following important additions:

- (i) Eosinophil chemotactic factor of anaphylaxis (ECF-A) released from sensitised tissues on exposure to antigen
- (ii) A specific eosinophil chemotactic factor produced by sensitised T-lymphocytes on exposure to antigen
- (iii) A pre-formed factor released from mast-cell granules (ECF-M) which may be identical with ECF-A
- (iv) A complement dependent factor EF-C

CYTOKINES IN INFLAMMATION AND IMMUNITY

Cytokines secreted by macrophages and lymphocytes (and occasionally by other cells) play a vital role in immune and inflammatory responses. These cytokines have previously been classified into lymphocyte-derived mediators (lymphokines) and those of monocyte origin (monokines) but recent changes in nomenclature have categorized them as interleukins. Other cytokines, such as interferons and tumour necrosis factor, continue under their original names.

1. Interleukins

Currently 12 different interleukins have been identified but the list will continue to grow and only

the better characterised are listed here:

(i) Interleukin-1 exists as two species (a and b) and are produced by macrophages, lymphocytes and a wide range of non-immune cells such as endothelial, epithelial and haemopoietic cells. Its principal effects include:

- a. Activation of TH- and B-cells
- b. Stimulation of thymocyte proliferation
- c. Induction of synthesis of acute phase proteins by the liver
- d. Activates eosinophils and basophils
- e. Promotes leucocyte/endothelial adhesion
- f. Increases collagenase synthesis by fibroblasts and chondrocytes
- g. Acts as a pyrogen

(ii) Interleukin-2 is synthesised and secreted by

T-lymphocytes following their activation by antigen and acts in an autocrine manner on the secreting cells and on other T-lymphocytes causing proliferation and expression of more IL-2 receptors. In this way the lymphocyte response is greatly amplified. IL-2 also induces T-lymphocyte cytotoxicity and stimulates natural killer cell activity. In combination with interferon, IL-2 also activates macrophages

(iii) Interleukin-3 is released by antigen activated

T-lymphocytes and acts as a stimulator of haemopoietic stem cells leading to the production of many of the major cell types in the bone marrow

(iv) Interleukin-4 is produced by a subset of T helper cells which also produces IL-5

and IL-6. Its most important action is in stimulating B-cell proliferation and regulating their production of immunoglobulin isotypes

(v) Interleukin-5 has multiple effects on B-cells leading to increased immunoglobulin secretion. It may also act as a stimulator of eosinophil growth and differentiation

(vi) Interleukin-6 is produced by activated macrophages and T-cells. Although originally described as a B-cell differentiation factor which stimulated antibody formation without prior cellular proliferation, IL-6 also serves as a co-stimulator of T-lymphocytes and induces the differentiation of cytotoxic T-cells. IL-6 has a multiplicity of actions including:

- a. Generates thrombopoietin to increase platelet numbers
- b. Increases the proliferation of a variety of cell types including keratinocytes, mesangial cells, and nerve fibres
- c. Has procoagulant properties
- d. Releases corticotrophin from the anterior hypothalamus
- e. In conjunction with IL-1 it stimulates acute phase protein production

(vii) Interleukin-7 is produced by stromal cells in the bone marrow and induces the proliferation

and differentiation of B-cell precursors

(viii) Interleukin-8 is produced by T-cells and activated macrophages and is a potent chemotaxin for polymorphs

2. Interferons

Three classes of interferon ((a,b and c) are recognised. IFN-a and IFN-b are important for their antiviral effects, but IFN-c has a wide range of activities and has a key role in immunoregulation. IFN-c is produced by antigen-specific T-cells and NK cells recruited by IL-2. Its activities include:

- (i) Activation of macrophages, which show enhanced phagocytosis and tumour killing capacity
- (ii) Activation and growth enhancement of cytotoxic T-cells and NK cells
- (iii) Induction of class II MHC expression on macrophages and many other types of cells
- (iv) Induces immunoglobulin secretion in B-cells primed by IL-2
- (v) Potentiates B-cell proliferation induced by IL-4

3. Tumour necrosis factors

TNF is found in two main forms TNF-a (also known as cachectin) has many actions in common with IL-1 and is released by macrophages, T-lymphocytes, NK cells, astrocytes and microglia, and Kupffer cells in response to inflammation and infection. The effects of TNF-a depend upon its concentration and duration of production, so that small amounts produce beneficial effects in inflammation and tissue repair, whereas sudden systemic release leads to shock and tissue injury and chronic over-production results in cachexia.

(i) Inflammation TNF-a acts as an inflammatory mediator by:

- a. increasing expression of ICAMs and ELAMs and improves leucocyte adhesion
- b. enhancing chemotaxis of macrophages and polymorphs
- c. increasing phagocytosis and cytotoxic activity TNF-a also acts as a pyrogen by
 - a. a direct effect on the hypothalamus
 - b. inducing IL-1 synthesis

(ii) Tissue repair.

TNF-a has an important role in tissue remodelling by virtue of its proliferative and destructive properties. On the one hand it can stimulate fibroblasts, osteoblasts, chondrocytes and endothelial cells to proliferate, and induce the synthesis of other growth factors, while on the other hand TNF-a can be directly cytotoxic to endothelial cells and promote the synthesis of proteases active against connective tissue matrix.

(iii) Septic shock.

TNF-a is now regarded as the central mediator of the pathophysiological changes consequent upon the release of lipopolysaccharide (LPS) from bacterial cell walls. Its effects include:

- a. Fever
- b. Respiratory arrest

- c. Capillary leak syndrome
- d. Haemorrhagic necrosis
- e. Lactic acidosis
- f. Release of 'stress' hormones
- g. Biosynthesis and release of reactive oxygen intermediates and arachidonic acid metabolites
- (iv) Cachexia.

Long term over-production of TNF-U, results in:

- a. Loss of fat and protein
- b. Anorexia
- c. Anaemia
- d. Fever
- e. Hypertriglyceridaemia
- f. Increased acute phase protein synthesis

TNF-b (also known as lymphotoxin) shares some of the biological activity of TNF-a. and basic fibroblast growth factor. It is responsible for some lymphocyte mediated tissue destruction.

Lymphocyte adhesion

Just as neutrophils attach to adhesion molecules on endothelial cells in an acute inflammatory response, lymphocytes possess integrins - lymphocyte function associated antigen I (LFA-1) and very late activation antigen 4 (VLA-4) which enable them to bind to adhesion molecules - intercellular adhesion molecule (ICAM-1) and vascular cell adhesion molecule (VCAM) expressed on endothelium in chronic inflammatory reactions. Such expression is induced by cytokines and interferons. This mechanism may direct the 'homing' of memory lymphocytes into an inflammatory response and also facilitate adhesion between lymphocytes and antigen-presenting cells.

Role of antibodies in chronic inflammation

- (i) Antigen binding followed by complement activation. Complement products facilitate phagocytosis or bring about cytolysis
- (ii) Bacterial agglutination
- (iii) Opsonisation of bacteria or foreign cells via Fc binding of phagocytic cells
- (iv) Neutralisation of toxins and virus infectivity

Inflammatory mediators and the immune response

Inflammatory mediators such as histamine, Prostaglandins, and beta-mimetic catecholamines (collectively termed 'autocoids') are capable of moderating a number of immune functions, usually by inhibition.

Receptors for autocoids on lymphocytes are non-randomly distributed. A proportion of suppressor T-cells always have receptors, but precursor B-cells and precursors of helper and cytotoxic T-cells do not. The inhibitory modulating effect is mediated by and directly proportional to the intracellular

concentrations of cyclic AMP generated by the autocoid. Thus autocoids generated in acute and chronic inflammation, or during an immunological reaction, not only mediate the inflammatory response but act as a feed-back mechanism modifying the immune response.

Autocoids have the following actions on lymphocyte responses:

- (i) After B-cells have been specifically stimulated to respond to an antigen, autocoids can inhibit the release of antibody
- (ii) T-cell cytolysis is inhibited by autocoids
- (iii) Histamine can induce a sub-set of T-suppressor cells to produce a suppressive factor which regulates the ability of another activated lymphocyte to pass through the cell cycle.

LEUCOCYTOSIS IN ACUTE AND CHRONIC INFLAMMATION

1. Neutrophilia in
 - (i) Pyogenic infections
 - (ii) Tissue breakdown - myocardial infarction, mesenteric infarction
2. Eosinophilia in
 - (i) Allergic disorders - hay fever, drug allergy
 - (ii) Parasitic infestation - trichinosis, schistosomiasis, filariasis, hydatid disease, strongyloides
 - (iii) Skin diseases - some cases of exfoliative dermatitis, dermatitis herpetiformis, pemphigus, eczema, psoriasis, scabies
 - (iv) Pulmonary eosinophilia - Loeffler's syndrome (simple pulmonary eosinophilia), prolonged pulmonary eosinophilia, tropical eosinophilia
 - (v) Polyarteritis nodosa
3. Lymphocytosis in
 - (i) Chronic infection - tuberculosis, secondary syphilis, brucellosis, typhoid fever
 - (ii) Viral infection - influenza, rubella, mumps, measles, chicken-pox, infectious mononucleosis
 - (iii) Whooping-cough
 - (iv) Acute infectious lymphocytosis
4. Monocytosis in some cases of
 - (i) Bacterial infections - tuberculosis, typhoid fever, brucellosis, subacute bacterial endocarditis
 - (ii) Protozoal and rickettsial infections - malaria, leishmaniasis, trypanosomiasis, Rocky Mountain spotted fever

6. Immunopathology

The immune system is concerned with the recognition of foreign materials (antigens) and through a variety of reactions rejecting or nullifying them. In carrying out these functions the system must be capable of distinguishing foreign, that is 'non-self', from 'self'. In the fetus the developing

CE EVOKED POTENTIAL

and the European TVEP QQC

(both patented and trademarked)

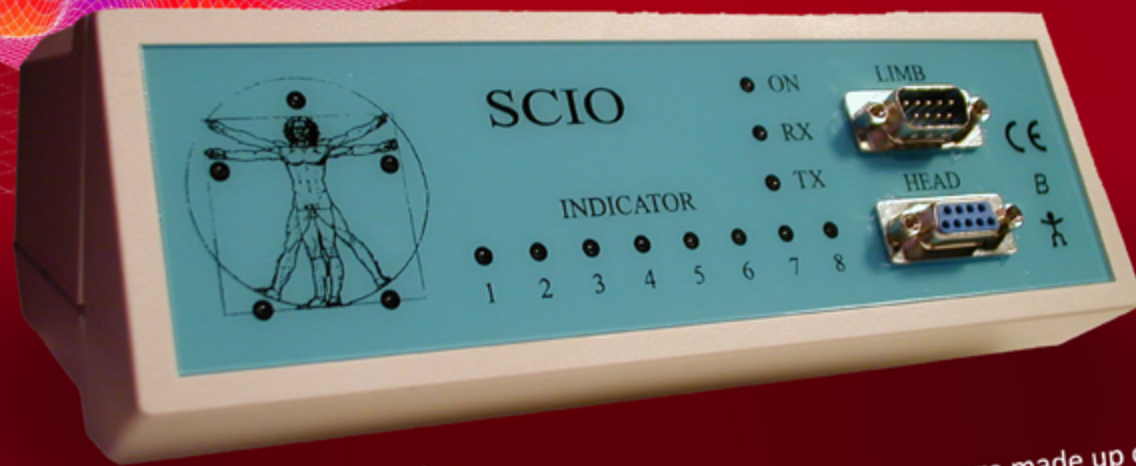

The QQC trivector device passes a changing low level field thru the item and generates a sophisticated picture of the electrical field of the item. It makes a 22X22X22 3D field that means over 10,000 separate frequencies to make one pattern. The shark senses these fields and they are amplified by the salt water. This study leads to the discovery of the electro-sense. Researchers have found that humans also have such a system but it is weak. Every item has such a field. Living things have a changing reactive field, non-living things have a static field non-changing. We now know that the electro-sense in humans is the surface of the skin and most concentrated in the sense of smell. So by measuring the Voltammetric electrical field of items and then amplifying the field 10 million times we get to really measure the patient's reaction to items, really. So by applying a trivector Voltammetric pattern we can measure the response or evoked potential and see the patient's reactivity. So 5 million dollars were spent buying and procuring the items in the matrix and testing these items with a patented registered technology of modern science. This is why the SCIO device works so well, at each treatment from calibration, test etc these QQC signatures are at the heart. Real science, real technology, real legal compliance, real items, real results, real honesty and integrity.

In 5th grade we were taught we are made up of atoms made of electrons and protons and neutrons. The electrons in the outer level are so charged they never touch. We are made of electrical fields.

The QQC is a very advanced patented trademarked technology with a CE mark. It measures in a very sophisticated process the Voltammetric electrical field of any item. If you look up voltammetry in Google you see thousands of references for a world recognized very scientific chemical process also referred to as Polography. You can see our patented process at <http://www.voltametriaqqc.ro/>

Shark Senses

Mary Ann Badavi & Stephanie Parker



- The bonnethead shark has an electrosense that is five million times greater than the electrosense of humans. Picture: Andy Murch/Elasmodiver.com

Electricity

- A shark's ampullae of Lorenzini are able to feel electric currents at short ranges.
- All living things emit a small electrical current, a shark can feel it from 0-8 Hz.



- It is also thought that the Hammerhead shark evolved its head to increase surface area for electrical reception.

lymphoid system is exposed to body constituents and is rendered unresponsive (tolerant) to these self proteins. When immunological maturity is established after the neonatal period, a non-self protein is recognised as foreign and a specific immunological reaction follows. There are two basic types of response.

- The formation of immunoglobulins which are released into the blood and other body fluids following a B-lymphocyte response - humoral antibodies
- The production of specifically sensitised small lymphocytes which possess antibody-like molecules on their surface (the T-cell antigen receptor - TCR) and by virtue of cytokine production or direct cytotoxicity are the effectors of cell-mediated immunity

In the majority of cases both types of response depend upon the initial recognition of a foreign antigen by T-lymphocytes. The ability of these cells to respond rests on their possession of a specific antigen receptor and correct presentation of the antigen by an appropriate major histocompatibility molecule on the antigen-presenting cell. The T-cell receptor is made up of two glycoprotein chains of differing composition (i.e. heterodimers) non-covalently linked to the T-cell surface antigen T3 (CD3). The majority of T-lymphocytes have an a/b heterodimer receptor but a small proportion (around 10%) have a c/d receptor.

The specificity of individual T-cells is determined during their development in the thymus. As the cells mature random rearrangement of the variable (V), diversity (D) and joining (J) gene segments at the a and b loci (or in another lineage at the c/d loci) leads via a multitude of combinations to the potential expression of millions of different TCR specificities. Not all specificities, however, are expressed following fetal development because of selection events in the thymus that restrict the T-cell repertoire to cells capable of recognising foreign antigens in the context of self MHC molecules. Thus positive selection allows the maturation of T-cells bearing receptors that bind self MHC in the thymus, whereas negative selection eliminates or nullifies those T-cells capable of reacting against self antigens thereby producing a state of tolerance.

THE HLA SYSTEM AND THE MAJOR HISTOCOMPATIBILITY ANTIGENS

The search for factors controlling the acceptance or rejection of tissues following transplantation, led to the identification of a complex series of histocompatibility antigens present on cell surfaces. The antigens were first identified on the surface of blood leucocytes and were therefore referred to as human leucocyte antigens (HLA).

The antigens comprising the HLA system are determined by genes situated on the short arm of the sixth chromosome, and the major loci have been designated A,B,C (Class I major histocompatibility antigens) and DR (Class II MHC antigens). In normal tissues expression of Class II antigens is confined to B-cells, monocytes/macrophages, dendritic cells, and vascular endothelium, whereas Class I antigens are expressed on all nucleated cells. Each locus possesses many different alleles which have been numbered, e.g. HLA-A8, HLA-B27, etc. Certain specific alleles of the various loci tend to be found together (as a 'haplotype') more frequently than would be expected by chance. This 'linkage disequilibrium' of alleles may exert a governing effect on general immune responsiveness.

Immune reactions might, however, be controlled by specific genes. Based on animal studies, immune responsive (1r) and suppressive (is) genes have been postulated which are either controlled by genes of the HLA system or are themselves linked to the HLA loci. Thus it has been shown, for example, that immune hyper-responsiveness toward many different antigens is associated with

two HLA haplotypes, A1,B8,Dw3 and A3, B7,Dw2.

TOLERANCE

Three main mechanisms have been proposed for the induction of self-tolerance in T- and B-lymphocytes, these are:

1. Clonal deletion

Engagement between the developing T-lymphocytes and selfantigens expressed on bone-marrow derived dendritic cells in the thymus leads to cell death by apoptosis and elimination of the auto-reactive T-cells.

2. Induction of clonal anergy

This mechanism assumes the survival of some self-reactive lymphocytes which have been rendered functionally inactive following interaction with thymic epithelium. This creates clones of T-cells anergic to epithelial-specific peptides. Such cells retain the capacity to bind to antigens but fail to produce lymphokines and do not proliferate.

3. Suppression

This mechanism assumes survival of auto-reactive lymphocytes which retain the ability to respond to self-antigens but are held in check by T-suppressor cells or their products.

When self-tolerance breaks down, the immune system may mount a cell-mediated attack or produce antibodies directed against the body's constituents - auto-immunity.

THE IMMUNE RESPONSE

A. Primary response

When foreign antigen is first introduced into the body it undergoes processing in antigen-presenting cells and the resulting peptide in combination with the appropriate MHC molecule is recognised by one or more specifically responsive small lymphocytes. B-lymphocytes may be activated directly by some antigens but most responses depend upon initial T-cell recognition.

(i) Cytotoxic T-lymphocytes are involved in the recognition and destruction of virally infected cells or rejection of foreign cells. These CD8+ lymphocytes recognise either foreign Class I MHC molecules on 'non self' cells, or react to viral antigens expressed at the surface of host cells in combination with Class I MHC antigens. Thus cytotoxic lymphocytes are generated that will react to a certain haplotype of MHC together with viral antigen but they will not kill cells of a different haplotype infected by the same virus. This mechanism, termed 'haplotype restriction' has probably evolved so that antigen receptors on T-cells do not become saturated with free virus and block their cytotoxicity.

(ii) Helper T-lymphocytes. These CD4+ cells co-operate with macrophages and assist B-cells to respond to certain (T-dependent) antigens. Helper T-cells only respond to antigen which following processing is presented in peptide form in association with major histocompatibility antigens of the Class II type (HLA- DR) on the surface of the individual's own monocytes, macrophages, dendritic or B-cells all of which act as antigen-presenting cells. However, under certain circumstances tissue cells may acquire Class II antigens (for example in rejection and after interferon stimulation) and this renders them capable of presenting antigens to helper/inducer cells.

Depending on their lineage the lymphocytes will react in different ways:

1. B-lymphocytes may react:
 - (i) Directly to a T-independent antigen, or
 - (ii) Only after interaction with a T-helper cell with the majority of antigens.

Following blast cell transformation the cell will either:

- (i) Develop rough endoplasmic reticulum and differentiate into a plasma-cell capable of manufacturing a specific immunoglobulin (in the first instance) of the IgM class, or
 - (ii) Revert to a small (B) lymphocyte and act as a primed memory cell
2. T-lymphocytes will undergo blast transformation and either:
 - (i) Proliferate to form a population (clone) of cells capable of acting as effector cells in a specific cell-mediated response. Such activated T-lymphocytes will act either as cytotoxic cells or secrete cytokines which will stimulate macrophages and enhance bacterial killing or recruit other lymphocytes and further amplify the response, or
 - (ii) Revert to a small (T) lymphocyte and act as a primed cell

B. Secondary response

On subsequent exposure to the same antigen, there is some interaction with pre-formed humoral antibody and with an enlarged population of responsive lymphocytes. There is therefore a greatly amplified humoral antibody response and a more rapid recruitment of sensitised cells. Memory B-cells are capable of secreting IgG and IgA immunoglobulins following appropriate antigenic stimulation (see below).

IMMUNOGLOBULINS

Immunoglobulins share a similar basic structure. They consist of two heavy and two light polypeptide chains linked by disulphide bonds. Splitting by papain produces two univalent fragments capable of binding antigen (Fab) and a third fragment without this capacity (Fc fragment).

The light chains are of two types, kappa (K) and lambda (L) and each immunoglobulin molecule has either two K or two L chains but never one of each. The heavy chains are of five major types and each molecule has a pair of identical type. Thus five distinct immunoglobulin classes are recognised on the basis of their heavy chains: IgG, IgA, IgM, IgD and IgE which have two c, a, m, d or e heavy chains respectively. Half of each light chain and a quarter of each heavy chain consists of a variable (v) region. The initial germ line DNA contains genes which code for different variable and constant (c) regions as well as different 'joining' genes which code for the amino acids of the region (j) joining constant and variable segments. The joining of v to j regions is imprecise so this adds further diversity to antibody structure. In the production of heavy chains additional variability is introduced by differences in the 'diversity' chain of DNA. Variation in all these components leads to the production of millions of different antibodies each of which is expressed on individual lymphocytes. Just as with T-lymphocytes, those B-cells bearing anti-self antibodies must be eliminated or nullified.

1. IgG is the major serum immunoglobulin accounting for about 70% of the total immunoglobulin pool. The heavy chains of IgG exist in four different forms so that four sub-classes can be distinguished (IgG1-G4)

Molecular weight = 150 000 Properties:

- (i) Crosses the placental barrier and is therefore the major protective immunoglobulin in the neonate
- (ii) Diffuses easily into all extracellular fluids
- (iii) Acts as an antitoxin (neutralising antibody)
- (iv) Responsible for opsonic binding of bacteria
- (v) Coats cells prior to killing by K-cells (macrophages and T-lymphocytes with specific cytotoxic activity related to their surface receptors for Fc)
- (vi) Complement activation by two or more molecules through their Fc portions

2. IgA represents 15-20% of the immunoglobulin pool. It exists as a monomer, dimers, trimers and polymers. It polymerises by spontaneous binding through a cysteine-rich polypeptide joining (J) chain (J-chain). It is secreted through epithelia as the dimer bound to a third polypeptide, the secretory or transport piece, which stabilises the molecule against proteolysis. IgA is therefore the major factor in 'secretory immunity'

Molecular weight = 160 000+

Properties:

- (i) Principal immunoglobulin in secretions such as those of the respiratory and gastrointestinal tracts and in sweat, saliva, tears and colostrum
- (ii) Prevents infection of mucous membranes by inhibiting adhesion of organisms to the epithelium
- (iii) When aggregated will bind polymorphs and activate complement by the alternate pathway

3. IgM accounts for about 10% of the immunoglobulin pool. This is usually a polymeric pentamer linked by J-chain, however a monomeric form is present on the surface of B-lymphocytes and acts as the antigen receptor

Molecular weight = 900 000 Properties:

- (i) Produced early in response to infection
- (ii) Largely restricted to plasma
- (iii) Act as agglutinating and opsonising antibodies

4. IgD accounts for less than 1% of the Ig pool

Molecular weight = 185 000 Properties:

? acts as a cytophilic antibody on B-lymphocytes and may play a role in antigen-induced lymphocyte differentiation

5. IgE

This is only present in trace amounts in the immunoglobulin pool Molecular weight = 200 000

Properties:

- (i) Becomes firmly fixed via its Fc fragment to mast cells and basophils. These coated cells degranulate when exposed to the appropriate antigen and release histamine and other agents
- (ii) May play a role in immunity to helminthic parasites

HYPERSENSITIVITY

Excessive or altered reactions to an antigen producing adverse effects are termed hypersensitivity or allergy. These reactions have been classified into five groups:

- Type I - Immediate (anaphylactic-type) hypersensitivity
- Type II - Cytotoxic type hypersensitivity
- Type III - Complex-mediated hypersensitivity
- Type IV - Cell-mediated (delayed-type) hypersensitivity
- Type V - Stimulatory hypersensitivity

Type I - Anaphylactic

A. Systemic anaphylaxis

Anaphylactic shock is characterised by intense bronchospasm, laryngeal oedema and a fall in blood pressure, and occasionally results in death. It can be provoked by injecting a large dose of an antigen some time after one or more smaller sensitising doses of the same antigen. The principal pathogenetic type is cytotoxic anaphylaxis where antigen reacts with antibodies (usually of the IgE class) bound to mast-cells or basophils by their Fc portions and results in the release of histamine and other mediators such as leukotrienes and platelet activating factor. Anaphylaxis can also result from Type III reactions (see below)

B. Local anaphylaxis (atopic allergy)

Local reactions result from the exposure of tissue mast-cells in sensitised individuals to specific antigens and are seen in three main situations:

1. Respiratory tract
 - (i) Allergic rhinitis (hay fever)
 - (ii) Extrinsic asthma
2. Intestine: Food allergy - shellfish, strawberries, etc.
3. Skin: Urticarial reactions to drugs, chemicals, injected antigens, etc.

In highly sensitised individuals provocation with the appropriate antigen may result in systemic anaphylaxis.

Type II - Cytotoxic

Reactions of this type occur when an antibody combines with an antigen on the surface of a cell

and results in cell-death by:

- (i) Complement-mediated cytolysis (C89)
- (ii) Phagocytosis of the cell in response to an opsonic antibody effect or by immune adherence (C3b)
- (iii) Promotion of cytotoxicity by cells activated through their Fc receptors. Such antibody-dependent cell-mediated cytotoxicity (ADCC) can be effected by monocytes, polymorphs and NK cells.

Examples:

- (i) Haemolysis resulting from antibodies directed against red-cell antigens or antigens attached to the surface
 - a. Transfusion reactions
 - b. Rhesus incompatibility
 - c. Auto-immune haemolytic anaemia
 - d. Drug-induced haemolysis, e.g. a-methyldopa, chlorpromazine, phenacetin
 - e. Associated infections, e.g. salmonellosis
- (ii) Thrombocytopenia following treatment with Sedormid (now withdrawn) and occasionally aspirin, tetracyclines, PAS, oestrogen and other drugs
- (iii) Agranulocytosis associated with amidopyrine, quinine, PAS, thiouracil, colchicine, phenothiazines, etc.
- (iv) Anti-glomerular basement membrane antibodies in Goodpasture's syndrome activate complement and provoke an acute inflammatory response in the glomerulus and lung
- (v) Hashimoto's thyroiditis

Type III - Complex-mediated

When large amounts of a soluble antigen are introduced into the circulation and an antibody reaction commences, immune complexes are formed in extreme antigen excess. These complexes (e.g. Ag2Ab, when antibody binds two antigen molecules) do not fix complement but can be cleared through Fc mediated phagocytosis by polymorphs and macrophages. When complexes are formed in the presence of higher concentrations of antibody (e.g. Ag3Ab2, Ag2Ab3) complement is activated and phagocytosis by the more efficient C3b mechanism follows. Accumulation of complexes in the circulation may result from defective phagocytosis or from excessive production in response to a large antigenic challenge. Small complexes are deposited in glomeruli whereas larger complexes by activating complement increase vascular permeability and may be found in the skin, the intestine, in synovial membranes, etc. When complexes are formed in antibody excess they tend to be insoluble and remain localised to the site of formation. Complexes of this type entering the circulation are cleared rapidly by macrophages of the RES.

Antigen-antibody complexes will initiate an acute inflammatory reaction by the activation of complement and subsequent formation of anaphylatoxins, leucotoxins, and aggregation of platelets. Tissue destruction may result from complement-mediated cytolysis or by release of

lysosomal enzymes from polymorphs which will also activate Factor XII and promote coagulation.

A. Antibody excess

- (i) Arthus reaction - an acute vasculitis produced by the introduction of antigen into the skin in the presence of high levels of precipitating antibody (IgG), e.g.
 - a. Reaction to insulin injection in sensitised diabetics
 - b. Erythema nodosum leprosum
- (ii) In the lung - extrinsic allergic alveolitis

Type III reactions to inhaled organic materials or microorganisms which lead to inflammation and fibrosis producing progressive restrictive lung disease

B. Antigen excess

- (i) Serum sickness - a syndrome characterised by pyrexia, urticaria, joint pains, generalised lymphadenopathy and albuminuria, which is occasionally seen following large injections of foreign protein
- (ii) Glomerulonephritis
 - a. Post-streptococcal and other infections
 - b. Systemic lupus erythematosus (SLE)
 - c. Quartan malaria
 - d. Drug-induced, e.g. penicillamine in rheumatoid arthritis
- (iii) Skin lesions
 - a. Erythema multiforme
 - b. Secondary syphilis
- (iv) 'Vasculitides'
 - a. Polyarteritis nodosa
 - b. Henoch-Schönlein disease
 - c. Drug-induced vasculitis
 - d. Wegener's granulomatosis (?)
- (v) Lung lesions due to such complexes occur in
 - a. Respiratory syncytial virus infection
 - b. Measles in an 'immunised' individual
- (vi) Central nervous system SLE
- (vii) Arthritis (associated with various viral infections)
- (viii) Rheumatic fever (complexes with streptococcal antigen deposited in small blood vessels in a wide variety of tissues)

Type IV - Cell-mediated (delayed-type) hypersensitivity

When a specifically sensitised T-lymphocyte (T-memory cell) comes into contact with the appropriate antigen it undergoes blast-cell transformation and cell division. Simultaneously, the cell produces numerous cytokines which promote a mixed inflammatory reaction.

T-lymphocyte responses are usually beneficial and underlie a number of important defence mechanisms against certain bacterial, viral and fungal infections (cell-mediated immunity). In some circumstances however they may have a deleterious effect and constitute a hypersensitivity reaction Examples:

- (i) Cell-mediated hypersensitivity to bacteria[antigens (bacterial allergy) is responsible for:
 - a. The Mantoux reaction to an intradermal injection of tuberculin
 - b. Caseation in tuberculosis
 - c. The tuberculoid form of leprosy

Contact hypersensitivity in the skin: simple chemicals acting as haptens attach to skin proteins and render them antigenic. The resulting cell-mediated response produces erythema, oedema and often vesiculation - contact dermatitis.

Common skin sensitisers are:

- Nickel
- Rubber
- c. Poison-ivy and primulus
- d. Topical medicaments - neomycin, lanolin, penicillin
- e. Iodine
- f. Dinitrochlorobenzene (DNCB)
- (iii) Graft rejection
- (iv) Some auto-immune diseases

Type V - Stimulatory hypersensitivity

Thus far only one example of this form of hypersensitivity has been defined and that is the stimulatory auto-antibody responsible for a type of thyrotoxicosis (Graves' disease). The auto-antibody, long-acting thyroid stimulator (LATS), is directed at the same surface receptor as is activated by TSH, and results in prolonged hypersecretion of thyroxine and triiodothyronine by the cell.

TISSUE TRANSPLANTATION

Nomenclature

Autograft - transplantation within the same individual Isograft or syngeneic graft - between identical twins or in-bred animals

Allograft - between individuals of the same species but of different genetic make-up (formerly

homograft)

Xenograft - between different species

Transplantation antigens

All nucleated cells possess surface histocompatibility antigens determined by separate gene loci. Tests for histocompatibility employ leucocytes and specific antisera. Although an individual's tissues are antigenically similar, the concentration of antigens varies from tissue to tissue, for example skin has a high concentration, whilst placenta, muscle, aortic wall, have low levels.

Rejection

Three patterns are described.

- (i) Hyperacute rejection occurs where there is major incompatibility with high levels of humoral antibodies resulting in an Arthus-type reaction
- (ii) Acute rejection occurs 2 to 3 weeks after grafting and results from antibody- and cell-mediated hypersensitivity. Destruction of the graft is brought about by:
 - a. The direct action of sensitised cytotoxic (CD8+) T-lymphocytes
 - b. Phagocytosis of graft cells by macrophages activated by cytokines or following C3b opsonisation
 - c. Attack by K-cells on IgG-coated graft cells
- (iii) Chronic rejection consequent upon gradual vascular obliteration, probably due to deposition of immune complexes and activation of complement and blood coagulation

Prevention of rejection

- (i) Favourable sites for transplantation
 - a. Cornea and anterior chamber of the eye
 - b. Meninges
 - c. Testis

These sites may be protected by virtue of unusual vascularity or lymphatic drainage

- (ii) Accurate tissue matching
- (iii) Immune deficiency states, pregnancy, and uraemia
- (iv) Immunosuppression
 - a. Corticosteroids
 - b. Azathioprine
 - c. Antilymphocyte serum
 - d. Whole-body irradiation
 - e. Induction of immune tolerance

AUTO-IMMUNITY

Mechanisms

The formation of antibodies or cell-mediated reactions directed against 'self' constituents may result from:

1. Alteration of self-proteins
 - (i) Combination with haptens, as in contact dermatitis and a-methyldopa-induced haemolysis
 - (ii) Modification by degenerative or infective conditions, e.g. to skin proteins following burns, red cells in mycoplasma infection, or to enzymically altered thyroglobulin or gammaglobulin.
2. Exposure of hidden antigens

Some antigens remain hidden or sequestered from the immune system and tolerance does not develop. On subsequent exposure in the mature animal they will be treated as non-self.

- (i) Spermatozoa. Orchitis may be followed by production of antisperm antibodies and lead to sterility
 - (ii) Lens protein. Degeneration and/or removal of a cataract may result in auto-antibodies and damage to the contralateral lens
 - (iii) Sympathetic iritis following damage to the contralateral iris
 - (iv) Release of myelin basic protein from the brain and the subsequent immune response may have a role in multiple sclerosis
3. Cross-reactions

Immune reactions to exogenous antigen may cross-react with self-proteins

- (i) T-lymphocyte responses induced by bacterial or parasitic heat-shock (stress) proteins may cross-react with self stress proteins with which there is considerable homology, e.g. T-lymphocyte responsive to mycobacterial stress proteins in rheumatoid arthritis
 - (ii) Antibodies to streptococcal antigens may react with constituents of cardiac muscle or connective tissue in rheumatic fever
 - (iii) An immune response to heterologous brain tissue in rabies vaccine may give rise to encephalitis
4. Breakdown of tolerance
 - (i) Genetic. An inherited defect or lack of efficiency in antibody production may lead to the formation of damaging antigen-excess complexes
 - (ii) Direct disturbance of the immune system by drugs, chemicals, infective agents, and neoplasia. Examples:
 - a. Hydralazine precipitating SLE
 - b. Virus infection of NZB mice appears to underlie the development of auto-immune haemolytic anaemia and complex-mediated glomerulonephritis
 - c. Chronic lymphocytic leukaemia and malignant lymphomas may be associated with auto-immune haemolytic anaemia
 - (iii) Stimulation of pre-existing clones of T- and B-cells capable of self-reactivity by infectious

agents or adjuvants, either directly or by eliminating the appropriate suppressor T-lymphocytes.

HLA AND AUTO-IMMUNE DISEASE

As outlined above there are strong links between the HLA system and normal immune reactivity. It is not surprising, therefore, that there exists a close association between certain HLA antigen types and auto-immune disease.

The basis for the relationship between auto-immunity and the HLA system rests on:

1. Communication between antigen-presenting cells and abnormal T- and B-subsets, namely:
 - (i) Increased numbers of activated T-helper cells
 - (ii) Decreased numbers of T-suppressor cells
2. Participation of complement

The link between auto-immunity and complement (which is genetically encoded in the HLA region) is exemplified by the finding that most patients with SLE carry at least one null allele for C4 and C2, suggesting that people with only one gene dose for these components are genetically susceptible to the disease

Examples of the association between HLA status and auto-immune disease include:

1. HLA-A3 Haemochromatosis
2. HLA-B8 with
 - (i) Coeliac disease
 - (ii) Dermatitis herpetiformis
 - (iii) Addison's disease
 - (iv) Graves' disease
 - (v) Chronic active hepatitis (auto-immune type)
3. HLA-B27 with
 - (i) Ankylosing spondylitis
 - (ii) Post-infective (e.g. gonococcal) arthritis
 - (iii) Acute anterior uveitis
4. HLA-DR2 with Multiple sclerosis
5. HLA-DR3 with
 - (i) Chronic active hepatitis
 - (ii) Sjögren's syndrome
6. HLA-DR3/DR4 Insulin dependent diabetes
7. HLA-DR4 with Rheumatoid arthritis

Pathogenesis of auto-immune disease

Auto-antibodies can be found in the sera of apparently healthy individuals and increase in

incidence with age. In most cases no harmful effects can be attributed to the antibodies. Auto-immune reactions having a primary role in disease operate through:

1. Humoral antibodies in
 - (i) Auto-immune haemolytic anaemia (anti-RBC antibodies)
 - (ii) Idiopathic thrombocytopenia (anti-platelet)
 - (iii) Some cases of lymphopenia (anti-lymphocyte)
 - (iv) Some cases of agranulocytosis (anti-neutrophil)
 - (v) Hashimoto's thyroiditis (anti-thyroglobulin, antimicrosomal)
 - (vi) Pernicious anaemia (anti-intrinsic factor, anti-parietal cell)
 - (vii) Some cases of male infertility (anti-spermatozoa)
 - (viii) Goodpasture's syndrome (anti-basement membrane)
 - (ix) Lens-induced endophthalmitis
 - (x) Thyrotoxicosis (stimulatory or anti-TSH receptor antibody)
2. Immune complexes in
 - (i) SLE (anti-DNA)
 - (ii) NZB mice infected with leukaemia virus
 - (iii) Aleutian mink disease
3. Cell-mediated reactions in
 - (i) Experimental allergic encephalomyelitis and in association with auto-antibodies in
 - (ii) Atrophic gastritis
 - (iii) Hashimoto's disease
 - (iv) Auto-immune orchitis

Diseases in which auto-antibodies are found but a primary role in producing the disease has not been established include:

1. Connective tissue disorders
 - (i) Rheumatoid disease - anti-IgG, anti-IgM antibody
 - (ii) Scleroderma - anti-IgG/antinuclear
 - (iii) Dermatomyositis - anti-IgG/antinuclear
 - (iv) SLE - lymphocytotoxic antibodies
2. Skin diseases
 - (i) Discoid lupus erythematosus - antinuclear/anti-IgG
 - (ii) Pemphigus - anti-intercellular cement substance
 - (iii) Pemphigoid - anti-basement membrane

- (iv) Dermatitis herpetiformis - anti-reticulin
3. Alimentary system
 - (i) Ulcerative colitis/Crohn's disease - lymphocytotoxic
 - (ii) Primary biliary cirrhosis - anti-mitochondrial
 - (iii) Chronic active hepatitis - anti-smooth muscle
 - (iv) Some cases of 'cryptogenic' cirrhosis
4. Others
 - (i) Idiopathic adrenal cortical atrophy (Addison's disease)
 - (ii) Sjögren's syndrome
 - (iii) Multiple sclerosis
 - (iv) Myasthenia gravis - anti-end-plate
 - (v) Juvenile diabetes mellitus

7. Resistance to infection

Resistance to infection is dependent upon:

- A. The general body defence mechanisms
 - B. Innate non-specific immunity
 - C. Acquired specific immunity
- A. BODY DEFENCES**
1. Physical barriers
 - (i) Skin
 - (ii) Urothelium
 - (iii) Mucous membranes of alimentary and respiratory tract
 2. Mechanical decontamination
 - (i) Desquamation of surface cells together with adherent organisms
 - (ii) Flushing of the urinary tract
 - (iii) Anatomical trapping, e.g. nasal turbinates
 - (iv) Mucus trapping and expulsion
 - (v) Dysfunction of cilia resulting from structural defects or an abnormal response to ATP may underlie some cases of: sinusitis and bronchitis
 3. Antimicrobial secretions
 - (i) Lysozyme (muramidase) in sweat, tears, saliva and tissue fluids
 - (ii) Acidity of sweat, gastric juice and vaginal secretion

- (iii) Unsaturated fatty acids in sebum and sweat
- (iv) Immunoglobulins, e.g. IgA in intestinal secretions
- (v) Basic polypeptides
- 4. Growth factor secretion
 - (i) EGF by Brunner's glands and salivary glands facilitates epithelial regeneration
 - (ii) TGF α by sweat glands
- 5. Surface phagocytosis by:
 - (i) Macrophages, e.g. alveolar macrophages
 - (ii) Epithelial cells, e.g. in the bladder
- 6. Competition by commensal organisms in:
 - (i) Upper respiratory tract
 - (ii) Mouth
 - (iii) Lower ileum and colon
 - (iv) Vagina
 - (v) Skin

B. INNATE IMMUNE MECHANISMS

1. Genetic factors
 - (i) Species, e.g. animals are generally resistant to syphilis, poliomyelitis, meningococcal meningitis whereas humans are immune to myxomatosis, foot and mouth disease, etc.
 - (ii) Race, e.g. Negroes and American Indians are more susceptible to tuberculosis than Caucasians
 - (iii) Individual (hereditary factors)
 - (iv) Sex. The male is more prone to fatal infectious disease than the female
 - (v) Age. The very young and the elderly are more susceptible to infection
 - (vi) Hormonal status, e.g. infections are more common in diabetes mellitus, steroid therapy, hypothyroidism
2. Cellular factors
 - (i) Phagocytosis by macrophages and polymorphs
 - (ii) Cytotoxicity by NK cells, usually large granular lymphocytes
3. Humoral factors
 - (i) Lysozyme is an enzyme which acts on the muramic acid present in bacterial cell walls
 - (ii) Complement. Activation of the alternate pathway by endotoxin may bring about several antimicrobial effects:
 - a. Bacteriolysis

- b. Opsonisation
- c. Immune adherence
- d. Leucotaxis
- (iii) Interferon, a non-specific anti-viral agent produced by a wide variety of cells but particularly by cells of the RES in response to an inducer which is probably the nucleoprotein component of the virion. Interferon is more important in the elimination of viruses in non-immune individuals than in preventing infection
- (iv) Acute phase proteins, e.g. C reactive protein acts as a natural' opsonin by binding to the C protein of pneumococci

C. ACQUIRED IMMUNITY

Acquired immunity implies the generation of a specific cellular or humoral response to the infective agent. Immunity is active where an individual mounts a cellular immune response or manufactures antibodies in response to an antigen, or passive where temporary protection is afforded by giving pre-formed antibodies.

1. Active immunity
 - (i) Natural, following previous infection
 - (ii) Artificial, by administering toxoid, killed or attenuated organisms
 - a. Toxoid, e.g. formaldehyde-treated exotoxin of diphtheria bacilli
 - b. Killed organisms, e.g. typhoid vaccine, poliomyelitis (Salk) vaccine
 - c. Attenuated organisms, e.g. Bacille-Calmette-Guerin vaccine is a live attenuated strain of *Mycobacterium tuberculosis*
2. Passive immunity
 - (i) Natural, transfer of antibodies of maternal origin
 - a. Trans-placental (IgG)
 - b. Intestinal absorption from colostrum and milk (IgA)
 - (ii) Artificial, by the administration of immunoglobulins
 - a. Homologous, e.g. pooled human gammaglobulin used in treatment of measles, hypogammaglobulinaemia, etc.
 - b. Heterologous, e.g. tetanus anti-toxin prepared in the horse

IMMUNITY TO BACTERIAL INFECTION

1. Humoral factors
 - (i) Secretory IgA antibodies may prevent attachment of bacteria to host cells
 - (ii) Antibodies to M proteins and capsules promote opsonization and phagocytosis by
 - a. Fc receptors
 - b. Complement activation and C3b adherence

- (iii) Complement activation via the alternate pathway by endotoxin (LPS)
 - (iv) Neutralising antibodies (anti-toxins) directed against bacterial exotoxins, e.g. antibodies against the erythrogenic exotoxin of *Streptococcus pyogenes* which gives rise to the skin changes of scarlet fever
 - (v) Antibodies directed against bacterial stress proteins
 - (vi) Serum lysozyme
2. Cellular factors
 - (i) Phagocytosis by polymorphs and macrophages
 - (ii) Killing mechanisms

These are enhanced by

- a. activation by bacterial products such as LPS, formyl-methionyl-leucyl-phenylalanine and related peptides
- b. activation by cytokines such as interferon- γ and TNF
- (iii) T-lymphocyte response directed at bacterial stress proteins

IMMUNITY TO VIRAL INFECTION

1. Humoral factors
 - (i) Neutralising antibodies in plasma are particularly important where there is a blood-borne phase before the virus reaches its target, e.g. poliomyelitis
 - (ii) Neutralising IgA antibodies in secretions from mucous membranes are important in preventing local infection, e.g. against influenza attack on the respiratory mucosa
 - (iii) Interferons. The anti-viral effects of interferons are mediated via
 - a. Direct inhibition of viral replication
 - b. Activation of NK cells and macrophages capable of destroying virus-infected cells
 - c. Increased expression of Class I and II MHC antigens which facilitates recognition of virus infected cells by T-lymphocytes
 - (iv) Tumour necrosis factor has anti-viral effects similar to the interferons
2. Cellular factors
 - (i) T-lymphocyte response with
 - a. Destruction of virus infected cells by cytotoxic T-cells
 - b. Cytokine stimulation of B-lymphocytes and macrophages
 - (ii) Phagocytosis of virus by macrophages with subsequent interferon production, or transfer of the inducer to other interferon-producing cells
 - (iii) Antibody dependent cell mediated cytotoxicity by K cells (large granular lymphocytes)

IMMUNITY TO PROTOZOA AND HELMINTHS

1. Humoral factors

Antibodies directed against surface antigens and stress proteins

 - (i) Lead to complement activation and lysis
 - (ii) Block invasion of host cells by blood-borne parasites
 - (iii) Enhance phagocytosis by Fc and C3b mechanisms
 - (iv) Facilitate antibody-dependent cell cytotoxicity (ADCC) by macrophages, neutrophils and eosinophils
2. Cellular factors
 - (i) T-cell production of cytokines such as IFN γ
 - (ii) Macrophage proliferation leading to granuloma formation. This may 'wall off' the parasites
 - (iii) Secretion of soluble 'killing' factors by macrophages
 - (iv) Killing by polymorphs and eosinophils. (The latter are recruited by a specific eosinophil stimulation promoter secreted by T-lymphocytes)

OPPORTUNISTIC INFECTION

Opportunistic infections are usually found in patients whose body defences or immune reactivity are impaired. The infective agents may be recognised pathogens, or increasingly, may be organisms of low pathogenicity often derived from the host flora.

Organisms of low pathogenicity or uncommon pathogens which are found in opportunistic infections include:

1. Fungi
 - *Candida albicans*
 - *Cryptococcus neoformans*
 - *Histoplasma capsulatum*
 - *Aspergillus fumigatus*
 - *Phycomycetes*
 - *Mucor*
 - *Rhizopus*
 - *Absidia*
2. Bacteria
 - *Nocardia asteroides*
 - Atypical mycobacteria
3. Viruses
 - Cytomegalovirus

- Varicella - herpes zoster Disseminated infection
- Measles
- Vaccinia

4. Pneumocystis carinii

Predisposing factors are:

1. Disturbance of physical body defences
 - (i) Surgery, e.g. infection by bacteroides, staphylococci
 - (ii) Trauma, e.g. staphylococci
 - (iii) Foreign bodies including urinary and intravascular catheters - Gram-negative bacilli, fungi
 - (iv) Burns - Pseudomonas
2. Alteration of flora by antimicrobial drugs, especially of the vagina and alimentary tract, e.g. Candidiasis, Clostridium difficile
3. Immunosuppressive treatment
 - (i) Corticosteroids
 - (ii) Irradiation
 - (iii) Chemotherapy various organisms, especially Gram-negative bacilli
4. Disorders of neutrophils

Staphylococci, streptococci, Gram-negative bacilli, fungi

5. Deficient humoral immunity, as in chronic lymphatic leukaemia or multiple myeloma: pyogenic cocci, Gram-negative bacilli, Listeria monocytogenes, Pneumocystis carinii
6. Deficient cellular immunity, as in AIDS and Hodgkin's disease, Pneumocystis carinii, atypical mycobacteria (M. avium-intracellulare), fungi, viral infections especially cytomegalovirus
7. Immunodeficiency of mixed type - viral infections, Pneumocystis carinii, Candida albicans
8. Post-splenectomy - Streptococcus pneumoniae, Neisseria meningitides, Haemophilus influenzae

8. Immune deficiency

The proper functioning of the immune system depends upon the integrity of the thymus, the bone marrow, and the lymphoid tissues, together with normal function of polymorphs, monocytes, and the complement system. Immune deficiencies can result from a congenital defect in any of these components (primary immunodeficiency) or may arise as a consequence of some other disease.

PRIMARY IMMUNODEFICIENCY

In view of the complex interactions between T- and B-lymphocytes, division of immunodeficiency into 'pure T-cell' and 'pure immunoglobulin' deficiencies is artificial.

1. Congenital sex-linked (Bruton's agammaglobulinaemia). This is an X-linked disease confined to males and is characterised by an almost complete absence of immunoglobulins from the serum. Affected individuals are particularly prone to bacterial infections and suffer from recurrent bronchitis, pneumonia, otitis media and skin infections.

2. Dysgammaglobulinaemia

(i) Selective IgA deficiency

Patients exhibit a wide range of clinical manifestations. Some are asymptomatic whilst others suffer repeated respiratory and intestinal infections, being particularly prone to intestinal giardiasis

Associations with IgA deficiency include:

- a. Atopic reactions
 - b. Malabsorption syndrome
 - c. Intestinal nodular lymphoid hyperplasia
 - d. Auto-immune haemolytic anaemia
- (ii) Wiskott-Aldrich syndrome

An X-linked or sporadic disorder characterised by low IgM levels associated with:

- a. Recurrent infections especially with Streptococcus pneumoniae and H. influenzae
 - b. Atopic eczema
 - c. Thrombocytopenia
- (iii) Ataxia-telangiectasia syndrome

A sex-linked disorder in which there is extremely low or absent IgA and occasional reduction in IgE or IgG. Patients exhibit:

- a. Recurrent respiratory tract infections
- b. Cerebellar ataxia
- c. Oculo-cutaneous telangiectasia

(iv) Common variable hypogammaglobulinaemia (CVH) Probably represents several different disease entities in that varying patterns of immunoglobulin deficiency are encountered. Most patients have low IgG and variable degrees of IgA and IgM deficiency. About 1/3 have reduced T-cells and show diminished delayed hypersensitivity skin-tests. The most common clinical manifestations are recurrent sinusitis, bronchiectasis, and pneumonias. These patients also have a high prevalence of autoimmune diseases, notably pernicious anaemia, haemolytic anaemia, and rheumatoid arthritis.

3. Defects in thymic development

- (i) Cellular immunodeficiency with immunoglobulins (Nezeloff syndrome) - results from isolated thymic aplasia (agenesis)
- (ii) DiGeorge's syndrome
 - a. Complete



HISTORY OF THE SCIO AND BIOFEEDBACK



THE SCIO
FINEST ENERGETIC MEDICINE



IN 1982 DR. NELSON WROTE THE FIRST EVER TREATISE ON QUANTUM BIOLOGY AND HE LAID THE GROUND WORK FOR THE SCIENCE OF THE QUANTUM XRROID INTERFACE SYSTEM.

FIRST DEVELOPED IN 1985 AND REGISTERED WITH THE FDA IN 1989 THE ELECTRO-PHYSIOLOGICAL FEEDBACK XRROID ENTERED THE MARKET PLACE. DAY TO DAY IMPROVEMENTS HAVE SHARPEN ITS OPERATION. THERE HAVE BEEN OVER A HUNDRED MEDICAL ARTICLES AND STUDIES PUBLISHED IN PEER REVIEWED MEDICAL JOURNALS ON THE TECHNOLOGY.

NOW REGISTERED IN MOST OF THE COUNTRIES OF THE WORLD THE EPFX TECHNOLOGY IS ADVANCING FAST. OVER 31,000 DEVICES HAVE BEEN SOLD WITH TREMENDOUS RESULTS WORLDWIDE. THE TESTIMONIALS FILE IS ASTOUNDING.

NOW THE SCIO AS IT IS CALLED TODAY OFFERS YOU THE FINEST ENERGETIC MEDICINE HAS TO OFFER WITH THE LARGEST MEDICAL SOFTWARE IN THE WORLD AVAILABLE FOR YOU.



Maldevelopment of the 3rd and 4th bronchial arches leads to thymic aplasia, absence of the parathyroids, and abnormalities of the aortic arch. There is a marked reduction in T-cell numbers

b. Partial

Thymic hypoplasia (under-development) leads to varying degrees of T-cell deficiency

(iii) Severe combined immunodeficiency disease (SCID) The thymic and lymphoid tissues are under-developed and there is a marked reduction in T- and B-cell numbers. SCID is thought to be due to enzyme defects in purine metabolism which are inherited as autosomal recessives.

4. Chronic muco-cutaneous candidiasis

In addition to repeated candida (and other) infections, patients frequently have an associated endocrine disorder such as

- (i) Diabetes mellitus
- (ii) Pernicious anaemia
- (iii) Addison's disease
- (iv) Gonadal dysgenesis

There are defects in T-lymphocyte, polymorph, and monocyte function.

Limited immunodeficiency

This implies susceptibility to only a single pathogen or only a narrow range of pathogens.

- (i) Fatal infectious mononucleosis (Duncan disease)
- (ii) Unusual susceptibility to H. influenzae epiglottitis

Complement deficiency

Genetic deficiencies of virtually all the complement components have been described. Those associated with systemic disease include:

- (i) C1, C2 and C4 defects

Abnormalities in the initial stages of the complement cascade are associated with an SLE-like syndrome with facial rashes, nephritis and arthritis. HLA control of immune responses and complement synthesis probably underlies this association

- (ii) C3 and C5 defects

As the cleavage products from these components are of fundamental importance in polymorph and monocyte chemotaxis (C3a, C5a) and in immune adherence (C3b), it is to be expected that deficiencies lead to recurrent bacterial infections. Depletion of C3 could also stem from a deficiency in C3 inactivator, as the latter deficiency results in continuous fluid-phase activation of C3 rendering it unavailable for the normal complement pathway

- (iii) C6, C7 and C8 defects

The final components of the complement pathway appear to be of particular importance in the clearance of Neisseria. Deficiency of these factors predisposes to disseminated infection with N. gonorrhoea and N. meningitides

If you need more information on the SCIO and purchase details please get in touch with us

Maitreya Kft.

tel: +3613036043 | web: www.qxsubspace.com | e-mail: info@qxsubspace.com



(iv) Alternate pathway defects

Recurrent infections may arise from a failure to generate opsonins through the alternate pathway. This is usually a result of Factor B deficiency

Defects in polymorph and monocyte function

1. Polymorph defects
2. Monocyte defects

Many diseases causing abnormal polymorph function also affect monocytes. Defective monocyte chemotaxis is also a feature of:

- (i) Chronic muco-cutaneous candidiasis
- (ii) Hyper-IgE syndrome
- (iii) Associated with various malignancies

SECONDARY IMMUNODEFICIENCY

The most notable example of secondary immunodeficiency is the acquired immunodeficiency syndrome (AIDS)

AIDS

AIDS results from infection by the human immunodeficiency virus (HIV), a retrovirus which binds to CD4+ (helper) T-lymphocytes and exerts cytopathic effects on them leading to profound depletion. The disease is of world-wide distribution and in the US and Europe is seen in the following groups:

1. Homosexual or bisexual males
2. Intravenous drug abusers
3. Blood and blood component recipients, e.g. haemophiliacs
4. Heterosexual contacts of infected individuals

In Africa heterosexual spread is paramount. As implied by the above high-risk groups, transmission of HIV is by sexual contact, parenteral administration or vertically from infected mothers to their offspring. The striking depletion of T-helper lymphocytes seen in AIDS means that patients are unable to mount antibody responses to new antigens and exhibit a marked reduction in cytokine synthesis which in turn affects macrophage function and haemopoietic growth and differentiation. The major disturbances of immune function are:

1. Lymphopenia
2. Decreased T-cell function results in opportunistic infection and increases susceptibility to neoplasms
3. Polyclonal B-cell activation gives rise to hypergammaglobulinaemia and circulating immune complexes
4. Impaired macrophage function

These defects in immune reactivity give rise to the following opportunistic infections:

1. Bacterial

- (i) Mycobacterial
 - a. Atypical e.g. *M. avium-intracellulare*
 - b. Disseminated *M. tuberculosis*
- (ii) Salmonellosis
2. Viral
 - (i) Cytomegalovirus
 - (ii) Herpes simplex virus
 - (iii) Varicella zoster virus
3. Fungal
 - (i) Candidiasis
 - (ii) Cryptococcosis
 - (iii) Histoplasmosis
4. Protozoal and helminthic
 - (i) Cryptosporidiosis
 - (ii) *Pneumocystis carinii*
 - (iii) Toxoplasmosis
 - (iv) Strongyloidosis

AIDS patients also develop an unusual pattern of malignant disease.

1. Kaposi's sarcoma - a multicentric neoplasm of vasoformative cells which follows an aggressive clinical course.
2. High-grade B-cell lymphoma resembling Burkitt's lymphoma.
3. Hodgkin's disease.
4. CNS lymphomas.

Other causes of secondary immunodeficiency are:

1. Excessive loss of immunoglobulins
 - (i) Protein losing enteropathy
 - (ii) Nephrotic syndrome
2. Depression of the immune system by
 - (i) Old age
 - (ii) Malnutrition
 - (iii) Virus infections such as measles
 - (iv) Leprosy
 - (v) Malaria

- (vi) Sarcoidosis
- (vii) Surgery
- (viii) Endotoxaemia
- (ix) Uraemia
- 3. Immunosuppression by
 - (i) Radiotherapy
 - (ii) Corticosteroids
 - (iii) Cytotoxic drugs
 - (iv) Antimetabolites
- 4. Neoplasia

Predominantly T-cell deficiency in:

- (i) Hodgkin's disease

Deficiency of normal immunoglobulins in:

- (ii) Multiple myeloma
- (iii) Waldenström's macroglobulinaemia

Mixed deficiency in:

- (iv) Non-Hodgkin's lymphoma
- (v) Chronic lymphocytic leukaemia
- 5. Loss of splenic function

Results in diminished clearance of particulate antigens and impaired production of IgM antibodies

- (i) Splenectomy
- (ii) Splenic atrophy
 - a. Coeliac disease
 - b. 'Idiopathic'

9. Granulomatous diseases

Chronic inflammatory conditions characterised by the finding of granulomas composed of circumscribed collections of modified (epithelioid) macrophages, unaltered macrophages and lymphocytes.

Epithelioid cells show reduced phagocytosis but exhibit a prominent endoplasmic reticulum and Golgi apparatus in keeping with enhanced secretory activity. The presence of non-degradable material and/or a T-cell response involving the production of INF-g, interleukin-1 and interleukin-4 is thought to be essential for granuloma formation.

MAJOR CAUSES OF GRANULOMAS

Diseases characterised by granuloma formation include:

1. Bacterial
 - (i) Tuberculosis
 - (ii) Leprosy
 - (iii) Atypical mycobacterial infection
 - (iv) Syphilis
 - (v) Cat scratch disease
 - (vi) Yersiniosis
2. Fungal
 - (i) Histoplasmosis
 - (ii) Cryptococcosis
 - (iii) Coccidioidomycosis
 - (iv) Blastomycosis
3. Helminthic
 - (i) Schistosomiasis
4. Protozoal
 - (i) Leishmaniasis
 - (ii) Toxoplasmosis
5. Chlamydia - lymphogranuloma venereum
6. Inorganic material
 - (i) Silicosis
 - (ii) Berylliosis
7. Idiopathic
 - (i) Sarcoidosis
 - (ii) Crohn's disease
 - (iii) Primary biliary cirrhosis

TUBERCULOSIS

An infective condition caused by Mycobacterium tuberculosis. Five varieties are recognised:

1. Human, 'classical' type
2. Bovine 3. Asian
3. African I (West Africa)

4. African II (East Africa)

Other potentially pathogenic mycobacteria include:

1. *M. man .num*
2. *M. ulcerans* I
3. *M. kansasii*
4. *M. scrofulaceum*
5. *M. xenopi*
6. *M. avium-intracellulare*
7. *M. paratuberculosis*

These are referred to as atypical, anonymous or opportunist mycobacteria.

Routes of infection

1. Inhalation - pulmonary infection, the most common route
2. Ingestion - tonsillar or small intestinal infection (now uncommon as bovine tuberculosis is eradicated in developed countries)
3. Congenital (rare)
 - (i) Blood spread via the placenta
 - (ii) Ingestion of infected amniotic fluid
4. Skin inoculation (very rare)

Primary infection

Initial infection leads in most cases to the formation of a circumscribed cellular reaction (the primary focus) and lymphatic spread of organisms to the regional lymph glands where a similar response develops. The primary focus and the involved regional glands are referred to as the primary complex.

In the majority of cases, infection is by inhalation and the Primary focus is usually found in a mid-zonal, sub-pleural situation (Ghon focus) with associated involvement of hilar lymph glands.

The fully-developed lesion has a characteristic microscopic appearance and is termed a 'tubercle' or tuberculous follicle.

Development of the tubercle

The body's response to *M. tuberculosis* passes through the following stages:

1. A short-lived acute inflammatory response with exudation of polymorphs
2. Accumulation of macrophages
3. Infiltration of surrounding tissue by specifically sensitised T-lymphocytes which secrete lymphokines including macrophage activating and cytotoxic factors
4. Phagocytosis of tubercle bacilli followed by development of epithelioid' features to form a granuloma

5. Some macrophages fuse to form Langhans giant cells characterised by a peripheral 'horse-shoe' arrangement of nuclei
6. Necrosis of the central zone with formation of structureless, finely-granular, eosinophilic material - caseous necrosis
7. Fibroblastic proliferation around the periphery with increasing collagenisation

The host response to tuberculosis

Resistance to tuberculosis varies between races and is modified by age, sex, hereditary and environmental factors.

Cell-mediated immunity is of far greater importance than humoral immunity in protection and takes the form of a hypersensitivity response to tuberculo-proteins derived from the bacillus, a form of bacterial energy.

Immune responses

1. Macrophage phagocytosis and 'processing'
2. Accumulation of sensitised T-lymphocytes and cytokine synthesis. The cytokines include:
 - (i) Mediators of acute inflammation, as seen at the site of tuberculin injection in a positive Mantoux test
 - (ii) Interleukins, interferon- γ and TNF which draw monocytes (macrophages) into the infected area and inhibit their further migration, activate the macrophages and enhance intracellular killing of mycobacteria
 - (iii) Cytotoxic factors which bring about destruction of macrophages and host tissue (caseous necrosis). Necrosis may be increased by ischaemia towards the centre of the tubercle
3. Fibroblastic proliferation is probably enhanced in immune patients by virtue of increased interleukin-1 production by activated macrophages

The course of the disease

This is dictated by:

1. Degree of resistance of the host
2. Virulence of the organism
3. Infecting dose

Effects of the primary complex

1. Systemic features

In most cases there are no signs of ill-health; a few patients have:

- (i) Malaise
- (ii) Fever
- (iii) Erythema nodosum
- (iv) Raised ESR

- (v) Lymphocytosis
- 2. Local effects resulting from lymph gland enlargement
 - (i) Peribronchial glands - lymph node compression syndrome
 - a. Lung collapse
 - b. Obstructive emphysema
 - c. Bronchiectasis
 - (ii) Cervical glands - disfiguring swelling in the neck

The fate of the primary complex

With most primary infections the development of specific cellular immunity is followed by progressive healing of the lesion.

1. Gradual destruction of the bacilli (this may never be completed)
2. Progressive fibrosis and slow removal of caseous material by macrophage activity
3. Calcification of persistent caseous debris or of the heavily collagenised scar tissue

Where the level of innate, and later specific, immunity is poor the lesion may spread directly, or through lymphatics, or through the blood stream.

Post-primary (adult or re-infection) tuberculosis

Pathogenesis

1. Activation of endogenous bacilli from a dormant primary lesion. The bacilli multiply when host general or local immunity deteriorates as a result of:
 - (i) Old age
 - (ii) Malnutrition
 - (iii) Immuno-suppressive treatment
 - (iv) Diabetes mellitus
 - (v) Coincidental fibrosing lung diseases such as silicosis
2. Re-infection by exogenous bacilli in a patient rendered hypersensitive by previous infection but whose overall level of immunity is inadequate

Post-primary, like primary, infection is usually seen in the lung but the lesion is typically apical (Assmann focus). There is early caseation and liquefaction because of previous sensitisation and the lesion may produce a large cavity, erode into a bronchus, and discharge infected necrotic material. Tuberculous bronchopneumonia may ensue, but progressive fibrocaseous destruction is more usual.

Spread of tuberculosis

1. Direct
 - (i) Lung
 - a. Acute tuberculous bronchopneumonia

- b. Fibrocaseous pulmonary tuberculosis
- c. Tuberculous empyema
 - (ii) Elsewhere, Coalescence of caseous foci and liquefaction gives rise to a so-called 'cold-abscess'
- 2. Lymphatic spread to regional lymph glands is invariable in primary infection, uncommon in post-primary
- 3. Blood spread

Organisms gain access to the circulation by:

- (i) Lymphatic connections, e.g. thoracic duct
- (ii) Rupture of a primary or post-primary focus into a vein
- (iii) Erosion of a blood vessel in an involved lymph gland

Two main patterns of blood spread are seen:

- (i) Widespread dissemination - miliary tuberculosis, to liver, spleen, kidneys, lungs, bone-marrow, adrenals, prostate, seminal vesicles, endometrium, fallopian tubes and meninges
- (ii) Single-organ involvement - implies that organisms carried to other sites are destroyed and infection progresses in an isolated organ. This may take many years to become clinically apparent by which time the pulmonary (or other) source of infection may have undergone healing by fibrosis and be difficult to identify. Common sites are meninges, kidneys, bone, fallopian tubes and epididymes

4. Infected sputum

- (i) Tuberculous ulcers in the larynx
- (ii) Ulcers in the small intestine (tuberculous enteritis) resulting from the swallowing of infected sputum

Organ involvement in tuberculosis

1. Lungs

- (i) Primary (Ghon) focus
- (ii) Post-primary (Assmann) focus
- (iii) Tuberculous bronchopneumonia
- (iv) Fibrocaseous pulmonary tuberculosis
- (v) Cavitation (may become super-infected by moulds such as *Aspergillus* species)
- (vi) Miliary lesions

2. Alimentary tract

- (i) Primary focus (rare)
- (ii) Post-primary focus tuberculous enteritis

3. Central nervous system

- (i) Small cortical lesion (Rich's focus)
- (ii) Leptomeningitis arising from
 - a. Direct haematogenous involvement of the choroid plexus
 - b. Rupture of a Rich's focus

Healed meningitis may give rise to hydrocephalus as a result of blockage of foramina by organised exudate.

Pachymeningitis around the cord may arise by extension of vertebral infection.

- (iii) Ischaemic lesions resulting from endarteritis obliterans
 - (iv) Tuberculous abscess (tuberculoma) which may develop in areas of cortical ischaemic necrosis
4. Urinary system
 - (i) Cortical lesions (appear first)
 - (ii) Tubular spread to involve pyramids and calyces - tuberculous pyelonephritis
 - (iii) Strictures at uretero-pelvic and uretero-vesical junctions
 - (iv) Tuberculous 'pyonephrosis'
 - (v) Spread to ureters, bladder, prostate and epididymis
 5. Genital tract
 - (i) Tuberculous salpingitis
 - (ii) Tuberculous endometritis
 - (iii) Tuberculous prostatitis
 - (iv) Tuberculous epididymitis
 6. Skeletal system
 - (i) Early lesions near the epiphyseal line
 - (ii) Destruction of cartilage and disc erosion
 - (iii) Synovitis and arthritis
 - (iv) Destruction of bone leads to pathological fractures and vertebral collapse (Pott's disease of the spine)
 - (v) Spread along fascial planes (psoas abscess)
 7. Skin
 - (i) Primary lesion (very rare)
 - (ii) Lupus vulgarism Most common on the face and neck, and may result in extensive tissue destruction and scarring. It is occasionally complicated by the development of squamous carcinoma
 - (iii) Scrofuloderma. Involvement of the skin by direct extension from an underlying lymph gland

- (iv) Papulo-necrotic tuberculide - probably represents an extreme hypersensitivity reaction to infection elsewhere in the body
- (v) Erythema nodosum
- (vi) Erythema induratum I hypersensitivity reaction

8. Serous cavities

Tuberculosis of serous linings produces an exudative response characterised by an outpouring of protein-rich fluid containing large numbers of lymphocytes.

- (i) Tuberculous pleurisy which may become an empyema
 - (ii) Tuberculous pericarditis may be followed by marked fibrosis and calcification producing constrictive pericarditis and cardiac failure
 - (iii) Tuberculous peritonitis may be a localised involvement associated with intestinal tuberculosis or salpingitis, or be generalised. This is a possible complication of laparotomy
9. Endocrine glands
 - (i) Tuberculosis of the adrenals (Addison's disease)
 - (ii) Tuberculous abscesses in the thyroid (rare)
 10. Eyes
 - (i) Tubercles of the choroid in miliary spread
 - (ii) Phlyctenular conjunctivitis
 - (iii) Iridocyclitis

LEPROSY

A chronic inflammatory disease of low infectivity caused by *Mycobacterium leprae*.

Route of infection

1. By inhalation of droplet infection
2. Through intact skin by direct contact

When infection develops in the skin, the initial lesion is the indeterminate macule. Thereafter two major clinical forms may develop.

A. Lepromatous leprosy

This occurs in patients who have low cell-mediated immunity because of an increased proportion of suppressor T-cells. Widespread infection ensues:

1. Skin involvement
 - (i) Papules
 - (ii) Nodules covered by greasy skin
 - (iii) Diffuse thickening, e.g. leonine facies
 - (iv) Loss of hair

On histology the skin shows

- (i) Dermal infiltrates rich in histiocytes
 - (ii) Clear area between epidermis and affected dermis
 - (iii) *M. leprae* in large numbers within histiocytes. These can be demonstrated using the Ziehl-Neelsen method without acid differentiation
 - (iv) Globi- enlarged, fat-laden histiocytes containing clumped degenerate bacilli
2. Nerve involvement
 - (i) Oedema and ischaemic necrosis
 - (ii) Progressive fibrosis
 - (iii) Peripheral neuritis which is symmetrical
 - (iv) Anaesthesia may lead to neuropathic arthropathy (Charcot's joints) and trophic ulcers
 3. Mucous membranes
 - (i) Nasal blockages and epistaxis
 - (ii) Ulceration of the nasal septum
 - (iii) Ulceration and stenosis of the larynx
 4. Mouth - loss of upper incisors
 5. Eyes
 - (i) Punctate keratitis
 - (ii) Iritis
 - (iii) Corneal ulceration
 6. Testes
Testicular atrophy leading to sterility and gynaecomastia
 7. Death may result from
 - (i) Respiratory infection; pneumonia, tuberculosis
 - (ii) Septicaemia from chronic osteomyelitis following infection of bone marrow
 - (iii) Renal failure due to chronic glomerulonephritis or amyloidosis

B. Tuberculoid leprosy

This develops when there is a high cell-mediated immunity because of increased numbers of helper T-cells. The infection is limited to skin and nerves.

1. Skin lesions

Scattered hypopigmented, anaesthetic areas showing anhidrosis

2. Nerve involvement

- (i) Destruction by granulomas

- (ii) Repair by fibrosis with consequent thickening

- (iii) Anaesthesia, muscle wasting

On histology these lesions show

- (i) A mass of lymphocytes and epithelioid cells
- (ii) Langhans-type giant cells
- (iii) Very few organisms
- (iv) Skin involvement extending through the dermis and epidermis in continuity
- (v) Caseous necrosis, sometimes within nerve lesions but not in the skin

Many of these features resemble those found in tuberculosis.

SARCOIDOSIS

This is a generalised disease of unknown aetiology characterised by widespread granuloma formation and protean clinical manifestations. It appears to be more common in communities which have recently eradicated tuberculosis and leprosy, but no definite link with these diseases has been established. Sarcoidosis may result from simultaneous viral and mycobacterial infection in which case viral infection is responsible for the observed T-cell depression and mycobacteria exert a stimulant effect on B-lymphocyte function, but this is speculation.

Immunological findings

The granulomas contain variable proportions of CD4+ helper cells and CD8+ cytotoxic-suppressor T-lymphocytes. Generalized immunological abnormalities include:

1. Depressed T-cell functions as shown by
 - (i) Cutaneous anergy (as manifest by a negative Mantoux)
 - (ii) Diminished response to non-specific mitogens
2. Exaggerated B-cell function as evidenced by increased circulating antibodies to a wide variety of antigens included EB virus, herpes simplex, rubella, measles, and parainfluenzae

The sarcoid granuloma

This consists of:

1. A well circumscribed collection of epithelioid macrophages
2. Giant-cells, mainly Langhans but also of foreign-body type
3. Inclusion bodies found in giant-cells (and occasionally in epithelioid cells)
 - (i) Residual bodies about 1 μ m in diameter which are end-stage phagosomes
 - (ii) Schaumann bodies - laminated, basophilic conchoidal bodies which when large become extracellular
 - (iii) Asteroid bodies - small star-shaped retractile inclusions
4. An outer narrow zone of lymphocytes
5. A collar of fibrous tissue

6. Central necrosis is uncommon and mild in degree. The reticulin framework is preserved whereas in caseation it is usually destroyed

These appearances although suggestive of sarcoidosis are not specific and may be found in many other conditions.

Sarcoid-like granulomata may be found in all granulomatous diseases (see p. 100) together with:

1. Foreign-body reactions
 - (i) Corn-starch grains (used in surgical glove powder)
 - (ii) Talc
 - (iii) Silica
 - (iv) Beryllium (formerly used in fluorescent tubes)
 - (v) Zirconium (used in deodorants)
2. Hypersensitivity reactions
 - (i) Allergic alveolitis
 - (ii) Arteritis
3. Hodgkin's disease in tissues not directly involved by neoplasm (e.g. liver/spleen)
4. 'Local' sarcoid reactions in lymph glands
 - (i) Draining a wide variety of tumours
 - (ii) In association with chronic cholecystitis (Cholegranulomatous lymphadenitis)
5. Drug reactions, e.g. liver granulomata with phenylbutazone

Organ involvement in sarcoidosis

1. Lungs

- (i) Widespread 'miliary' lesions
- (ii) Linear fibrosis radiating from the hilum
- (iii) Diffuse fibrosis which may progress to 'honeycomb lung'
- (iv) Collapse secondary to bronchial obstruction (rare)

2. Lymph glands. Hilar gland involvement is common

3. Skin

- (i) Erythema nodosum is common
- (ii) Boeck's sarcoid - purple/red papules, nodules or plaques found principally on the face, as well as on the extensor surfaces of the arms and upper back
- (iii) Darier-Roussy sarcoid - where the lesions are subcutaneous rather than intracutaneous and are found on the trunk
- (iv) Lupus pernio - characterised by indurated, erythematous bluish-red macules and plaques found on the face, ears and fingers

4. Eyes

- (i) Uveitis - inflammation of the iris and ciliary body
- (ii) Conjunctivitis
- (iii) Retinal lesions
- (iv) Keratoconjunctivitis sicca

5. Salivary glands resulting in enlargement and loss of secretion. Sarcoidosis is one of the many causes of Mikulicz's syndrome (bilateral enlargement and loss of secretion in salivary and lachrymal glands). Involvement is sometimes accompanied by uveitis and pyrexia - uveoparotid fever (Heerfordt's syndrome)

6. Liver involvement, whilst common, is rarely of clinical significance

7. Spleen. Sarcoidosis is a rare cause of mild to moderate splenomegaly

8. Bone. Small cystic lesions in the phalanges of the feet and hands

9. Heart. Myocardial granulomata and fibre atrophy may lead to heart failure or conduction defects

10. Pituitary and hypothalamus. Sarcoidosis is a rare cause of diabetes insipidus

11. Central nervous system (uncommon)

- (i) Meningoencephalitis
- (ii) Peripheral neuropathy
- (iii) Transverse myelitis
- (iv) Multifocal leucoencephalopathy

12. Kidneys mainly involved by nephrocalcinosis consequent upon hypercalcaemia and hypercalciuria which result from vitamin D sensitivity with increased uptake of calcium from the gut

13. Skeletal muscle - sarcoid myopathy.

Histological diagnosis

1. Kveim test. This consists of an intradermal injection of saline suspension of a sarcoid lymph gland or spleen. A positive reaction, which takes about 6 weeks to develop, appears as a firm nodule with the features of a sarcoid granuloma on histology

2. Biopsy of lymph gland, liver, skeletal muscle, labial salivary glands, skin or even lung may reveal the characteristic granulomas.

SYPHILIS

Syphilis is an infective disease which can spread to the fetus to give rise to congenital syphilis or acquired through sexual contact. The agent responsible is the spirochaete *Treponema pallidum*.

Natural history of acquired syphilis

1. Inoculation followed by an incubation period of 2-4 weeks but possibly 10-90 days

2. The primary lesion which is usually present for 6-8 weeks
3. Involvement of regional lymph nodes and spread into the blood stream
4. The secondary stage may take up to 9 months to disappear
5. The latent stage where there are no signs and symptoms but the infection is still present and active. The disease may then undergo spontaneous cure
6. The tertiary stage becomes clinically apparent 3-10 years after infection
7. Later involvement of the cardiovascular and nervous systems. This may take up to 20-40 years to present clinically. The late nervous system involvement is sometimes referred to as quaternary syphilis

Primary syphilis

The primary lesion is the chancre, which when fully developed is a hard, painless, indurated ulcer with regular, well-demarcated margins. Histologically there is:

1. Ulceration
2. Underlying granulation tissue
3. Endothelial proliferation in small blood vessels
4. Heavy plasma-cell and lymphocytic infiltration
5. Healing by fibrosis producing a small scar. Spirochaetes may be demonstrable by a silver impregnation method such as the Levaditi stain

Secondary syphilis

The lesions are very variable:

1. Skin rashes (syphilides)
2. Mucous membranes
3. Lymphadenitis
4. Hepatitis
5. Iritis
6. Arthritis, bursitis and periosteitis
7. Meningitis (rare)

Tertiary syphilis

The characteristic lesion is the gumma. This comprises:

1. A central zone of structured necrosis in which the original architecture can usually be distinguished
2. A surrounding zone of epithelioid cells and occasional giant cells
3. Granulation tissue heavily infiltrated by plasma cells and lymphocytes
4. Fibrosis

5. Endarteritis obliterans

Lesions are found in:

1. Skin and subcutaneous tissue
2. Mucous membranes
3. Bones, e.g. 'worm-eaten' skull
4. Liver
5. Testis
6. Rare sites - muscles and joints, gastrointestinal tract, lung, spleen, urinary tract

Cardiovascular syphilis (tertiary)

1. Aorta - syphilitic mesaortitis

This is the commonest manifestation of tertiary syphilis and is an important cause of death

Pathogenesis

- (i) Infection around adventitial vessels spreads into the wall along vasa vasorum
- (ii) Endarteritis obliterans develops in these small nutrient vessels
- (iii) Ischaemia leads to necrosis of the media with destruction of elastic lamina

These changes are most marked in the proximal part of the thoracic aorta

Effects

- (i) Aneurysm formation (saccular or dissecting)
- (ii) Aortic incompetence
- (iii) Coronary ostial stenosis leading to myocardial ischaemia
2. Small arteries
 - (i) Intimal proliferation
 - (ii) Adventitial fibrosis produce endarteritis obliterans which may lead to ischaemic damage
3. Heart; Gumma (very rare).

Neurosyphilis (?quaternary)

Treponema invade the CNS in up to 20% of cases during the early stages of syphilitic infection. In the absence of treatment approximately half of these patients will develop signs of neurosyphilis after a lapse of many years.

1. Connective tissues and blood vessels (meningovascular)
 - (i) Leptomeningitis which may be complicated by cranial nerve palsies and internal hydrocephalus
 - (ii) Pachymeningitis

- (iii) Gummata in the meninges
- (iv) Endarteritis obliterans leading to cerebral infarcts
- 2. Parenchymal involvement
- (i) General paralysis of the insane (GPI)

A chronic syphilitic encephalitis with widespread lesions and diverse motor, sensory, and psychiatric symptoms. The main pathological features are:

- a. Degeneration of nerve cells and fibres with cerebral atrophy
- b. Proliferation and hyperplasia of microglia forming 'rod-cells'
- c. Reactive proliferation of astrocytes - gliosis
- d. Thickening of leptomeninges
- e. Perivascular infiltration by lymphocytes and plasma cells
- (ii) Tabes dorsalis

This is the equivalent lesion in the spinal cord and involves lower sensory neurones.

Pathological features:

- a. Wasting of the posterior roots
- b. Thickening of the pia-arachnoid
- c. Gross demyelination of the dorsal columns

Effects:

- a. Loss of coordination with ataxia
- b. Deep anaesthesia resulting in Charcot's joints and penetrating ulcers

Congenital syphilis

The fetus may be overwhelmed by infection and die. In those that survive, the lesions found during the first 2 years are similar to those of the secondary stage. Many of the lesions appearing in the third year and after are of the gummatus type. The scars of deformities resulting from early or late lesions which have healed are termed stigmata.

10. The effects of infection and injury on the body

Inflammatory conditions and major tissue injury are frequently associated with a wide range of systemic responses which embrace vascular, metabolic, endocrine, neurological and immunological functions. Those occurring soon after the onset of infection or injury are called the acute phase response. The acute phase response has the outstanding characteristic of being a generalised host reaction irrespective of the localised or systemic nature of the initiating disease, and several components of the response are remarkably constant despite the considerable variety of pathological processes that induce it. This uniformity of reaction points to the involvement of relatively few mediators in the overall 'orchestration' of the acute phase response. The major mediator coordinating the response is interleukin-1, aided and abetted by tumour necrosis factor

(TNF α). Thus the mononuclear phagocyte system, which serves as the major source of these cytokines, plays a pivotal role.

Mononuclear cells are stimulated to produce IL-1 and TNF α by:

1. Bacterial endotoxin - lipopolysaccharide (LPS), especially when complexed with LPS-binding protein.
2. Antigen-antibody complexes.
3. Intact micro-organisms following phagocytosis.
4. Other cytokines produced by activated lymphocytes and macrophages.

Interleukin-1 and TNF α have a multiplicity of biological activities at the following sites:

1. Hypothalamus - fever
2. Bone marrow - neutrophilia
3. Neutrophils - activation
4. B-lymphocytes - antibody production
5. T-lymphocytes - IL-2 production
6. Liver - acute phase proteins
7. Fibroblasts - proliferation and collagen synthesis
8. Muscle - protein catabolism with amino-acid release

COMPONENTS OF THE ACUTE PHASE RESPONSE

A. Fever

Body temperature is controlled partly by reflexes initiated by the thermosensory nerve endings in the skin, but principally by a central control mechanism in the hypothalamus. The central mechanism can be likened to a thermostat, and this thermosensory centre (shown in animals to be in the anterior hypothalamus) responds to variations in the temperature of blood flowing through it. Signals from the thermosensory centre influence the activity of other hypothalamic centres which regulate the physiological processes responsible for heat production and heat loss, thus controlling the core temperature. In fever the thermostat is set high and a rise in temperature is achieved by increasing heat production and inhibiting heat loss by:

1. Cutaneous vasoconstriction:
 - (i) Coldness and pallor of the skin at the onset of fever
 - (ii) Contraction of the erector pili muscles ('gooseflesh') maintains an insulating layer of air next to the skin
2. Higher metabolic activity particularly in skeletal muscles and in the liver
3. Shivering - associated with increased catabolic activity and heat production in skeletal muscles.

Fever is accompanied by general malaise and anorexia. If the temperature rises to 41.6 °C

(107 OF) there is a danger of direct thermal injury to various tissues, and particularly to cerebral neurones. However, a potentially beneficial effect of hyperthermia is augmentation of the immune response by T-helper cells. The high setting of the thermosensory centre in fever is brought about by interleukin-1. The effect of interleukin-1 on thermoregulation is mediated by Prostaglandins, in particular by PGE₂. This mechanism underlies the value of drugs like aspirin, an inhibitor of prostaglandin synthesis, in reducing fever.

B. Neutrophil leucocytosis

Normally the neutrophil count is between 2.5-7.5 x10⁹/litre. In infections this rises to 10-20 x 10⁹/litre - particularly with pyogenic bacteria.

Lesser degrees of neutrophil leucocytosis occur in:

- (i) Pregnancy
- (ii) Strenuous exercise
- (iii) Severe mental stress
- (iv) Injection of glucocorticoids or adrenaline
- (v) Following necrosis of tissue, e.g. myocardial infarction

Leucocytosis may develop within a few hours of the onset of a bacterial infection and is of diagnostic value. This early rise is due partly to release of many polymorphs which normally lie marginated in the venules of the lungs and elsewhere, and partly due to release of immature polymorphs lying in the sinusoids of the red marrow. The leucocytosis is maintained, however, by an increased rate of formation in the marrow. As polymorphs have a life span of about 12 hours, death and loss of polymorphs in exudation, for example in a suppurating infection requires a large output requiring hyperplasia of the myeloid or granulocyte series in the bone marrow.

Interleukin-1 has a central role in neutrophil leucocytosis. It promotes:

- (i) Release of neutrophils from their marginated state
- (ii) Increases granulopoiesis

Actions on neutrophils themselves include:

- (i) Release of granules
 - Lactoferrin - Iron-chelation
 - Lysozyme - Antibacterial properties
 - Increases oxidative activity
- (iii) Increased hexose mono-phosphate shunt activity

C. Acute phase and stress proteins

In febrile conditions or following injections of endotoxin or

interleukin-1 there is a dramatic increase in the synthesis of intracellular stress (heat shock) proteins and some proteins by the liver. These latter proteins enter the circulation and can be detected within a few hours of the onset of fever which is why they are labelled acute phase proteins.

1. Acute phase proteins These include:

- (i) C-reactive protein
- (ii) Fibrinogen
- (iii) Haptoglobin
- (iv) Ceruloplasmin
- (v) Amyloid A and P proteins

Interleukin-1 promotes protein catabolism in skeletal muscle and a flux of amino acids into the liver where protein synthesis is substantially increased. There is evidence of independent regulation of each of the acute-phase proteins. Some of these proteins, for example haptoglobin (an α_2 globulin capable of binding free haemoglobin) and fibrinogen are normally present in substantial levels in plasma but increase 2 or 3 fold after interleukin-1 injection. Others which normally occur at low levels, e.g. C-reactive protein, increase several hundred fold. Likewise some appear rapidly, but others require several days to reach maximum levels. C-reactive protein is capable of binding in a non-immunological way to 'foreign' antigens and activating the classical complement pathway. It thus acts as an opsonin and prepares material for phagocytosis.

2. Stress proteins

Stress (or heat shock, HSP) proteins are present in all living systems and are among the most highly conserved in nature. Their intracellular production is induced by rises in temperature and synthesis commences rapidly (within 5-15 minutes) after the onset of 'heat shock'. Other stimuli which induce the synthesis of stress proteins include:

- (i) Cytotoxic agents
- (ii) Free radicals, e.g. in reperfusion injury
- (iii) Cellular poisons, like alcohol and heavy metals
- (iv) Certain viral infections

Stress proteins together with ubiquitin are involved in the transport and degradation of proteins denatured by cell injury so that, for example, proteins 'tagged' with ubiquitin can undergo proteolysis and be recycled into the cell's economy, while HSPs and other chaperones regulate the assembly and disassembly of proteins and provide a means of shuttling polypeptides between molecular structures.

D. Nutritional responses

Following major infection or injury the body goes into substantial negative nitrogen balance, part of which meets the increased caloric needs of fever. Accelerated muscle protein degradation leads to myalgia and reduced physical performance. Interleukin-1 acts directly on skeletal muscle to promote protein catabolism, an effect mediated by an accumulation in the muscle of PGE₂ which ultimately activates proteolysis in the lysosomes. This brings about amino-acid release from muscle which helps to satisfy the increased energy requirements via gluconeogenesis, but also contributes to the synthesis of proteins in proliferating immunological cells and the synthesis of acute phase reactants released from the liver.

Start the path to peak performance with
SCIO
at home

The SCIO can be prescribed for HOME USE to help your children with autism, attention difficulties, superlearning, sports, injury, pain, relaxation....



Home Use of **SCIO**

Monthly rental fees can be as low as
 350 Euro a month.
 Contact your SCIO therapist for
 information...

If you need more information on the SCIO
 and purchase/rental details please get in touch with us

Maitreya Kft.
 tel: +3613036043 | web: www.qxsubspace.com | e-mail: info@qxsubspace.com



Changes in trace metals

The serum levels of iron and zinc are depressed in the acute phase of bacterial infection. There is evidence that the decrease in serum iron is probably important in protecting the host against various bacteria as a reduction in iron suppresses the growth rate of various micro-organisms. Iron appears to be sequestered by the binding substance lactoferrin, and lactoferrin/iron complexes are deposited in the tissues. Interleukin-1 has been shown to activate lactoferrin release from neutrophils. There is also an increase in serum copper levels in keeping with the increase in the coppertransport protein ceruloplasmin. Copper is involved in enzyme and transport mechanisms but its role in fever is unknown.

E. Vascular responses and shock

Selective arterial constriction increases peripheral resistance and tends to compensate for diminished cardiac output. The main vessels involved are those of the skin and splanchnic circulation, whilst blood flow to the heart, brain and skeletal muscle is maintained at normal levels. When vasoconstriction fails to maintain normal blood pressure the clinical picture of shock develops. Underperfusion of tissues leads to accumulation of acid metabolites and vessels may cease to respond to normal constrictor stimuli. Progressive and irreversible arteriolar dilatation occurs and blood is 'sequestered' in the greatly enlarged capillary reservoir. Intractable hypotension results and this constitutes a lethal condition sometimes termed 'irreversible shock'.

Main types and causes of shock

1. Hypovolaemic
 - (i) Haemorrhage
 - (ii) Loss of plasma, e.g. burns
 - (iii) Loss of fluid and electrolytes, e.g. severe diarrhoea
2. Cardiogenic
 - (i) Myocardial infarction
 - (ii) Major pulmonary embolism
 - (iii) Following cardiac surgery
 - (iv) Myocarditis and other causes of acute cardiac failure
3. 'Septic'
 - (i) Endotoxic, mediated by bacterial lipopolysaccharide e.g. endotoxin
 A from *Pseudomonas aeruginosa*
 - (ii) Exotoxic, e.g. exotoxin from *Staphylococcus aureus* (toxic shock syndrome)
4. 'Vascular'
 - (i) Anaphylactic
 - (ii) Neurogenic, e.g. spinal injuries

Pathogenesis

1. Hypovolaemia - a fall in cardiac output resulting from reduced blood volume
2. Cardiogenic - a fall in output resulting from inadequate heart function ('pump failure')
3. Septic shock
 - (i) Release of TNF α and IL-1 in high concentration
 - (ii) Induction of nitric oxide synthetase in endothelial and vascular smooth muscle cells leads to a build up of nitric oxide (NO) which is responsible for sustained vasodilation and hypotension
 - (iii) Activation of complement with release of anaphylatoxins C3a/C5a
 - (iv) Activation of neutrophils leads to endothelial damage resulting in capillary leakage
 - (v) Activation of Factor XII initiates coagulation and bradykinin formation. The former may lead to disseminated intravascular coagulation
4. Vascular mechanisms
 - (i) Pooling of blood in
 - a. Large peripheral vessels due to loss of vasomotor tone
 - b. Capillaries resulting from persistent venular constriction
 - (ii) Increased vascular permeability
 - (iii) Slowing of blood flow resulting from 'sludging' of red cells

Disseminated intravascular coagulation (DIC)

This is a condition in which the activation of coagulation factors leads to deposition of platelet-fibrin thrombi in small vessels throughout the body. The consumption of coagulation factors and activation of fibrinolysis frequently leads to life-threatening haemorrhage.

F Metabolic reactions

Features of the early metabolic reaction are:

1. Hyperglycaemia
2. Fall in body temperature
3. Decreased oxygen consumption
4. Alteration of intracellular oxidative mechanisms
5. Loss of albumin from plasma due to transcapillary escape

Irreversible shock

Features include:

1. Reduced oxygen consumption
2. Diminished heat production
3. Increasing hypoxia
4. Metabolic acidosis

5. Hypotension
6. Hypoglycaemia

G. Hormonal reactions

Increased production of:

1. Catecholamines which
 - (i) Increase cardiac output
 - (ii) Constrict arterioles
 - (iii) Increase gluconeogenesis
2. Corticosteroids which bring about
 - (i) Retention of Na⁺
 - (ii) Excretion of K⁺
 - (iii) Catabolism of proteins
3. Aldosterone
Potassium deficiency
4. ADH
Water retention

PATHOLOGICAL LESIONS IN SHOCK

1. Kidneys
 - (i) Acute tubular necrosis
 - (ii) Glomerular microthrombosis
 - (iii) Acute cortical necrosis (rare)
2. Lungs - 'shock lung' or adult respiratory distress syndrome Features
 - (i) Congestion and intraseptal oedema
 - (ii) Microthrombi
 - (iii) Hyaline-membrane formation
 - (iv) Atelectasis
 - (v) Interstitial pneumonia
3. Liver
 - (i) Centrilobular ischaemic necrosis
 - (ii) Fatty change
4. Adrenals
 - (i) Lipid depletion (compact-cell change) in cortex

- (ii) Focal necrosis of cortical cells
- (iii) Massive haemorrhage (Waterhouse-Friderichsen syndrome)

5. Heart

- (i) Subendocardial haemorrhage
- (ii) Contraction bands within myocytes

6. Gastrointestinal tract

- (i) Acute ulceration of the stomach and duodenum (Curling's ulcers)
- (ii) Haemorrhagic gastroenteropathy

Focal or more extensive haemorrhage into the stomach or intestinal mucosa associated with local superficial ulceration, probably resulting from hypoxia

7. Brain

Anoxic or hypoxic encephalopathy (see p. 338)

8. Pituitary

Necrosis following hypovolaemia (most commonly due to postpartum haemorrhage) giving rise to:

- (i) Acute insufficiency - Sheehan's syndrome
- (ii) Chronic insufficiency - Simmond's disease

LATE REACTIONS TO INJURY AND INFLAMMATION

A. Metabolic reactions

Catabolic phase

1. Rise in oxygen consumption
2. Rise in body temperature
3. Catabolism of protein increased
4. Increased mobilisation of fatty acids
5. Increased gluconeogenesis from amino acids derived from muscle

Anabolic phase

1. Positive nitrogen balance restored
2. Electrolyte equilibrium regained

B. Haematological reactions

1. Increased formation of platelets
2. Increased fibrinogen production
3. Decreased plasminogen
4. Anaemia

5. Lymphopenia

Hormonal reactions

Increased production of

1. Insulin which stimulates glucose uptake, and glycogen, fat and protein synthesis
2. Growth hormone - possibly involved in the mobilisation of adipose tissue
3. Thyroxine

D. Immunological reactions

1. Reactive changes in lymphoid tissues, e.g. hyperplasia in lymph nodes, splenomegaly
2. Production of IgM antibodies directed at various components of the injured tissues

E. Amyloidosis

Although the synthesis of amyloid precursor proteins is part of the acute phase response to inflammation, when inflammation is prolonged the sustained increase in the serum concentrations of these proteins leads to the appearance of fibrillar material (amyloid) in many different tissues. However, amyloid is not a specific protein. It can be composed of one or more proteins or glycoproteins all having a characteristic b-pleated fibrillar appearance on electron microscopy. Thus, amyloid complicating long-standing inflammation is made up of amyloid A (AA) and P (AP) proteins derived from partial degradation by macrophages of SAA and SAP proteins. Another major form of amyloid is composed of AL protein which is derived from immunoglobulin light chains, mainly of lambda type. In addition, a heterogeneous collection of amyloid types (some of which have not been characterised) are found in certain hereditary or familial conditions and as localized deposits.

Diseases associated with amyloid deposition

1. AA/AP amyloid

- (i) Chronic infections (of long standing)

- a. Tuberculosis
- b. Bronchiectasis
- c. Osteomyelitis
- d. Pyelonephritis
- e. Leprosy
- f. Syphilis

- (ii) Chronic inflammatory disorders

- a. Rheumatoid disease
- b. Crohn's disease
- c. Systemic lupus erythematosus
- d. Pustular psoriasis

- (iii) Malignant states
 - a. Hodgkin's disease
 - b. Carcinomas of bladder, kidney, stomach, bronchus, ovary
- 2. AL amyloid
 - (i) Multiple myeloma
 - (ii) Waldenström's macroglobulinaemia
 - (iii) Solitary plasmacytoma (localised)
- 3. Hereditary/familial types
 - (i) Amyloid polyneuropathy
 - (ii) Amyloid cardiomyopathy
 - (iii) Amyloidosis associated with Mediterranean fever
 - (iv) Familial amyloid nephropathy, urticaria, and deafness
 - (v) Familial cutaneous amyloid
- 4. Localised amyloid deposition
 - (i) Senility
 - a. Heart
 - b. Brain - also in Alzheimer's disease
 - c. Islets of Langerhans
 - d. Seminal vesicles
 - (ii) Endocrine tumours
 - a. Medullary carcinoma of the thyroid (AMCT)
 - b. Pituitary adenoma
 - c. Islet-cell tumours of the pancreas
 - (iii) Non-endocrine tumours
 - a. Naso-pharyngeal carcinoma
 - b. Basal cell carcinoma
 - (iv) In the islets of Langerhans in diabetes mellitus
 - (v) Tumour-like deposits in:
 - a. Larynx, trachea, bronchi, and lung
 - b. Genito-urinary tract
 - c. Eye
 - d. Tongue

- e. Heart
- f. Skin

Pathogenesis

It is believed that amyloids are produced by partial degradation of precursor proteins. Degradation of AA protein takes place either in endothelial cells or in fixed macrophages of the RES, particularly in sinusoid lining cells, and this may explain the tendency for amyloid to be deposited in relation to vascular basement membranes. The abnormal, or incomplete, degradation of the precursor proteins may be under the influence of a further protein synthesised by the liver which has been termed amyloid enhancing factor (AEF).

AL amyloid is thought to arise by partial degradation of immunoglobulin light chains produced in excess by abnormal populations of plasma cells.

Detection of amyloid

1. Of historical interest, iodine and dilute sulphuric acid produce blue coloration similar to that obtained with starch (Latin-amylum)
2. Congo-red and Sirius-red stain amyloid orange/red and when viewed under polarised light gives apple-green birefringence
3. Thioflavine-T staining gives rise to yellow fluorescence in ultraviolet light
4. Amyloid has a characteristic ultrastructural appearance being composed of parallel arrays of fibres 7 to 10 nm diameter
5. Potassium permanganate staining reveals different structural forms

Organ involvement in amyloidosis

1. Kidney

Amyloid is deposited in:

- (i) Glomeruli (mesangium and basement membrane)
- (ii) Tubular basement membranes
- (iii) Blood vessel walls

Results in:

- (i) Nephrotic syndrome
- (ii) Renal vein thrombosis
- (iii) Haematuria
- (iv) Nephrogenic diabetes insipidus

2. Spleen Deposited in:

- (i) Malpighian bodies (sago spleen)
- (ii) Diffusely in the walls of sinusoids

Results in:

No significant disturbance of function

3. Liver

Deposited in:

- (i) The space of Disse between the sinusoid lining cells and the hepatocytes
- (ii) Blood vessel walls

Results in:

- (i) Pressure atrophy of hepatocytes. In extreme cases this may lead to liver failure
- (ii) Portal hypertension if involvement of the central veins leads to outflow obstruction

4. Heart

Deposited in:

- (i) Subendocardial zone
- (ii) Interstitial connective tissue

Results in:

- (i) Cardiomegaly and cardiac failure
- (ii) Disturbances of rhythm

5. Adrenal glands

Deposited in the zona glomerulosa and then advances throughout the cortex

Results in Addison's disease (rarely)

6. Gastrointestinal tract

Deposited in:

- (i) The vicinity of epithelial basement membranes
- (ii) Walls of small blood vessels
- (iii) As plaques in the submucosa

Results in:

- (i) Macroglossia
- (ii) Dysphagia (oesophageal rigidity)
- (iii) Malabsorption syndrome
- (iv) Diarrhoea
- (v) Protein-losing enteropathy
- (vi) Pseudo-obstruction
- (vii) Ulceration of plaques

7. Skin

Forms:

- (i) Lichen amyloidosis
- (ii) Localised nodular amyloidosis

F Calcification

Calcification other than that normally occurring in the teeth and skeletal system (heterotopic calcification) is seen in the following circumstances:

1. Associated with advancing age Deposits are found in:

- (i) Pineal gland
- (ii) Tracheal and laryngeal cartilages
- (iii) Costal cartilages
- (iv) Dura mater

2. In dead or degenerate tissue (dystrophic calcification) Examples

- (i) In old tuberculous lesions
- (ii) In scars
- (iii) In dead parasites
- (iv) In degenerate tumours, especially uterine leiomyomata (fibroids)
- (v) In atheromatous plaques

In association with increased levels of calcium (or occasionally with increased phosphate) in the blood and tissues, usually derived from the skeleton but also involving increased absorption from the intestine and decreased loss through the kidneys. Such calcification occurs in previously normal tissues and is referred to as metastatic.

It is found in:

- (i) Hyperparathyroidism

Primary, due to:

- a. Adenoma
- b. Hyperplasia
- c. Carcinoma (very rarely)

Secondary, due to:

- a. Chronic renal failure
- b. Renal tubular acidosis
- c. Malabsorption states
- d. Pregnancy and lactation

- (ii) Carcinomatosis with or without skeletal involvement, especially with bronchial and breast cancer.

- (iii) Myelomatosis
- (iv) Vitamin D sensitivity, as in sarcoidosis and infantile hypercalcaemia
- (v) Excessive administration of vitamin D
- (vi) Paget's disease of bone (when immobilised)
- (vii) Hypophosphatasia
- (viii) Milk-alkali syndrome
- (ix) Hypoparathyroidism (deposits in the basal ganglia)

Sites of metastatic calcification

- (i) Kidneys, producing nephrocalcinosis which may lead to renal failure
- (ii) Stomach
- (iii) Lungs, on the elastic fibres of the alveolar septa
- (iv) Blood vessels
- (v) Cornea

4. In calculi (stones)

Many calculi include calcium salts among their constituents.

Calculi are found in:

- (i) Urinary tract
 - a. calcium phosphate
 - b. calcium oxalate
 - c. calcium carbonate
- (ii) Biliary system
 - a. calcium bilirubinate
- (iii) Salivary glands
- (iv) Pancreas
- (v) Prostate

5. In neoplasia

Microscopic laminated calcified bodies - calcospherites are found in association with:

- a. Adenocarcinoma of the ovary
- b. Papillary carcinoma of the thyroid
- c. Meningioma (psammoma bodies)
- d. Benign and malignant breast lesions
- e. Oligodendroglioma

11. Fluids and ions

COMPOSITION

Osmolality (solute concentration per kg water) is the same in all compartments.

1. Extracellular fluid (ECF) is similar in composition to plasma but has a low protein content. The principal cation is sodium, and the major anions are chloride and bicarbonate.
2. Intracellular fluid (ICF) has a high protein content. The principal cations are potassium and magnesium, and the main anions are phosphate and proteins. The difference between the sum of the concentrations (in mEq per litre) of the major plasma cations and anions is known as the 'anion gap'.

$$\text{Anion gap} = (\text{Na}^+ + \text{K}^+) - (\text{Cl}^- + \text{HCO}_3^-)$$

The anion gap is increased when there are raised levels of acidic ions which are not included in the calculation, e.g. lactate, acetoacetate, phosphate, hydroxybutyrate, etc.

CONTROL

Plasma volume can only be maintained if the hydrostatic pressure in the vascular compartments is balanced by equal and opposite effects. The relative distribution between extra- and intracellular compartments is determined by the osmolar contents of each compartment as osmolality is equal in the two compartments. Control of the extracellular compartment is primarily by:

1. Volume control

This is primarily by regulation of the renal re-absorption of Na⁺ Cl⁻, and water

2. Osmoality control

This is regulated by water intake and excretion modified by

- (i) Thirst
- (ii) Anti-diuretic hormone secreted by the posterior pituitary in response to stimulation by
 - a. Osmoreceptors in the hypothalamus
 - b. Baroreceptors sensitive to blood volume changes

3. pH control

This is regulated by

- (i) Buffers; bicarbonate ions, phosphate ions and protein
- (ii) Respiratory control of bicarbonate
- (iii) Renal excretion of acidic groups

DISTURBANCE OF WATER BALANCE

- A. 'Pure' water depletion (i.e. in excess of sodium deficit)

Causes:

1. Decreased intake

2. Increased loss
 - (i) Lack of ADH (diabetes insipidus)
 - (ii) Unresponsiveness of the renal tubules to ADH
 - a. Nephrogenic diabetes insipidus
 - b. Hypercalcaemia
 - c. Hypokalaemia
 - (iii) Failure of tubular water re-absorption (despite cellular response to ADH)

Effects:

1. Increased osmolality of extracellular fluid
2. Transfer of water from intracellular compartment to equilibrate osmolality
3. Cellular dehydration which may lead to hypotension and coma

B. 'Pure' water excess

Causes:

1. Excessive intake
 - (i) Large infusions of glucose solution in post-operative patients
 - (ii) Administration of water to patients who are sodium depleted
2. Diminished excretion
 - (i) Poor renal function
 - (ii) Diminished fluid delivery to the distal tubule usually resulting from increased reabsorption of Na⁺ and water in the proximal tubule, e.g. in cardiac failure
 - (iii) Continued secretion of ADH despite lowered plasma osmolality
 - a. In response to volume depletion, e.g. following blood loss
 - b. Secretion of ADH by oat-cell carcinoma of the bronchus

Effects:

1. Decreased osmolality of the extracellular fluid
2. Transfer of water into cells causing intracellular oedema which may lead to disturbances in CNS and renal function

DISTURBANCES OF SODIUM BALANCE

A. Sodium (and water) deficiency -'dehydration'

Causes:

1. Severe vomiting or diarrhoea
2. Excessive sweating ('heat exhaustion')
3. Diuretic treatment

Effects:

1. Transfer of water into cells
2. Diminished extracellular volume - haemoconcentration
3. Low renal blood flow causes rise in plasma urea
4. Low urine output
5. Clinically:
 - (i) Dehydration
 - (ii) Muscular irritability - cramps
 - (iii) Hypotension with shock in severe cases

B. Sodium (and water) excess

Causes:

1. Excessive salt consumption, especially in infants
2. Excessive administration of saline solutions to patients in acute renal failure or post-operative patients

Effects.

Expansion of the extracellular compartment may lead to generalised oedema

DISTURBANCE OF POTASSIUM BALANCE

A. Potassium depletion (hypokalaemia)

Causes:

1. Low intake - this is an unusual cause but can be a contributory factor in the elderly
2. Increased loss in the urine
 - (i) Diuretic treatment
 - (ii) Primary hyperaldosteronism
 - (iii) Cushing's syndrome
 - (iv) Secretion of ACTH by oat-cell carcinoma
 - (v) Renal tubular disorders with failure of urinary acidification
3. Increased loss from the gut
 - (i) Diarrhoea (including purgative abuse)
 - (ii) Excessive mucus secretion by a colo-rectal villous adenoma
 - (iii) Watery diarrhoea, achlorhydria, hypokalaemic syndrome (Werner-Morrison syndrome) due to VIP secreting tumour

Effects.

1. Cardiac

- (i) Increased sensitivity to digoxin
- (ii) Ectopic beats, paroxysmal atrial tachycardia
- (iii) Dilatation
- 2. Muscle weakness involving
 - (i) Skeletal muscle
 - (ii) Smooth muscle of the gut
 - (iii) Vascular smooth muscle leading to hypotension
- 3. Renal
 - (i) Polyuria (diminished response to ADH)
 - (ii) Diminished reabsorption of Cl⁻ and increased reabsorption of bicarbonate, leads to high HCO₃⁻ and low Cl⁻ in the plasma (hypokalaemic alkalosis)
 - (iii) Vacuolation of tubule-lining cells (vacuolar nephropathy)
 - (iv) Pyelonephritis

B. Potassium excess (hyperkalaemia)

Causes:

An increased load in the presence of diminished renal function

- (i) Acute renal failure with anuria
- (ii) Chronic renal failure
- (iii) Excessive potassium administration in the elderly, or in saline-depleted patients, with poor renal function

Effects:

- 1. Cardiac arrhythmias
- 2. Muscular weakness
- 3. Paraesthesiae
- 4. Confusion

DISTURBANCES OF ACID-BASE BALANCE

A. Respiratory acidosis

Inadequate ventilation leads to retention Of CO₂ with formation of carbonic acid. Although the level of HCO₃⁻ also rises, it does so to a much lesser degree, so that according to the equation:

$$\text{pH} = \text{pK} + \log \frac{\text{HCO}_3^-}{\text{a}[\text{pCO}_2]}$$

(where pK = 'dissociation constant' and a = 'solubility coefficient') the rise in the partial pressure Of CO₂ leads to a fall in pH.

Respiratory acidosis leads to:

- 1. Increased renal excretion of H⁺ and ammonia
- 2. Lowering of plasma Cl⁻ level

B. Respiratory alkalosis

Hyperventilation results in excessive 'blowing Off' Of CO₂. The fall in pCO₂ is associated with a rise in blood pH. The kidneys attempt to compensate by increasing excretion of bicarbonate ions and reduced secretion of H⁺ ions.

C. Metabolic acidosis

The fundamental change is a primary reduction in [HCO₃⁻] followed by a fall in pH. Metabolic acidosis is usually due to increased production or ingestion of acid substances which result in a high anion gap.

However, in other circumstances there may be loss of bicarbonate ions and a relative increase in chloride ions so that there is 'hyperchloraemic acidosis' with a normal anion gap.

- 1. Acidosis with a high anion gap

Causes:

- (i) Lactic acidosis
 - a. Increased production of lactic acid in hypoxic tissues
 - b. Failure to metabolise lactic acid in liver and renal diseases, and in patients receiving phenformin
- (ii) Chronic renal failure as there is diminished excretion of phosphate and sulphate ions
- (iii) Ketosis in:
 - a. Diabetes mellitus
 - b. Starvation
- 2. Hyperchloraemic acidosis

Causes:

- (i) Excessive loss of bicarbonate ions from gastrointestinal secretions
 - a. Diarrhoea
 - b. Pancreatic fistula
- (ii) Renal tubular acidosis
 - a. Failure of acidification in the distal tubule
 - b. Failure of HCO₃⁻ reabsorption in the proximal tubule
- (iii) Uretero-colic anastomosis (after removal of the bladder) leads to increased - absorption of Cl⁻ from the colon in exchange for HCO₃⁻

Effects of acidosis

- 1. Deep, rapid respirations ('air-hunger')

2. Poor cardiac function
3. Neurological disturbances
4. Shock, coma, and death

D. Metabolic alkalosis

Causes:

1. Excessive loss of gastric acid
 - (i) Persistent vomiting
 - (ii) Continuous suction
2. Excessive intake of alkali - e.g. sodium bicarbonate in large quantities for 'indigestion'
3. Severe hypokalaemia

Effects:

1. Respiratory depression
2. Neurological disturbances
3. Tetany

12. Oedema and congestion

OEDEMA

Oedema is an excessive accumulation of fluid in the interstitial tissues. Accumulations in the body cavities are termed ascites (peritoneum), hydrothorax or pleural effusion, and pericardial effusion.

The fluid may be either an exudate or a transudate.

Exudate. High specific gravity (>1.020) fluid containing all the plasma proteins including fibrinogen and numerous inflammatory cells, and resulting from increased vascular permeability.

Transudate. Low specific gravity (< 1.012) fluid containing small amounts of albumin and few cells. It arises from an imbalance in those forces tending to move fluid out of the vessels and those tending to retain it within them.

Even when excessive quantities of fluid are passing out of vessels, increased lymphatic drainage may prevent the appearance of oedema. Conversely, lymphatic obstruction may itself produce oedema when the other factors are at normal levels.

Oedema may be generalised or localised.

A. Generalised oedema

1. Increased hydrostatic pressure of the blood
 - (i) Cardiac failure
2. Decreased osmotic pressure of the blood
 - (i) Excessive loss of protein

- a. Proteinuria, e.g. nephrotic syndrome
- b. Protein-losing enteropathy
- (ii) Inadequate synthesis of protein
 - a. Hepatic cirrhosis
 - (iii) Inadequate intake of protein
 - a. Malnutrition (Kwashiorkor)
 - b. Prolonged starvation
 - c. Malabsorption syndrome
3. Sodium retention with expansion of the extracellular fluid compartment
 - (i) Renal vasoconstriction and/or diminished glomerular filtration rate
 - a. Cardiac failure
 - b. Nephrotic syndrome
 - c. Acute glomerulonephritis
 - (ii) Increased levels of aldosterone secondary to:
 - a. Cardiac failure
 - b. Nephrotic syndrome
 - c. Hepatic cirrhosis (failure of inactivation)
 - (iii) Excess ACTH or cortisone
 - a. Therapeutic
 - b. Cushing's syndrome
4. Generalised increase in vascular permeability
 - (i) Hypoxia
 - (ii) Bacterial toxins
 - (iii) Chemicals
5. Diminished tissue tension
 - (i) Loss of elasticity with age
 - (ii) Change in the ground substance, e.g. rendered more soluble by corticosteroids in Cushing's syndrome

B. Localised oedema

1. Increased hydrostatic pressure of the blood due to:
 - (i) Venous obstruction
 - a. Venous thrombosis
 - b. Strangulation o vu us

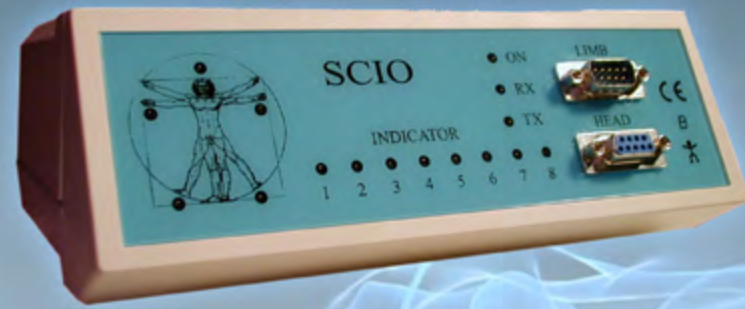

Spinal injury and pain

Using MTENS, and TVEP the SCIO can treat the spinal area for injury and pain.

Sending in an auto-focused sophisticated pulse different for each patient based on their personal electrical needs.

If you need more information on the SCIO and purchase details please get in touch with us

Maitreya Kft.

tel: +3613036043 | web: www.qxsubspace.com | e-mail: info@qxsubspace.com



c. External pressure on veins

- Gravid uterus
- Ligatures/tourniquets
- Tumour

d. Hepatic cirrhosis (portal hypertension)

- (ii) Gravity, e.g. ankle oedema after prolonged standing
- 2. Increased vascular permeability
 - (i) Chemical irritants giving rise to
 - a. Urticarial reactions in skin
 - b. Pulmonary oedema
 - (ii) Immunological reactions resulting in complement activation with release of anaphylatoxins. Angioneurotic oedema is included in this category and results from genetically determined absence or deficiency of C1 esterase inhibitor
 - (iii) Other causes of acute inflammation
- 3. Lymphatic abnormalities
 - (i) Congenital malformation, e.g. Milroy's disease
 - (ii) Obstruction secondary to:
 - a. Carcinoma
 - b. Irradiation
 - c. Filariasis
 - d. Recurrent bacterial lymphangitis

PULMONARY OEDEMA

Causes

- 1. Raised left atrial pressure
 - (i) LVF
 - (ii) Mitral stenosis
- 2. Raised pulmonary capillary pressure
 - (i) Over infusion
 - (ii) Acute renal failure
 - (iii) Venocclusive disease
- 3. Increased capillary permeability
 - (i) Infection
 - Bacterial/viral pneumonias

- (ii) Drug reactions
Iodine, nitrofurantoin, busulphan, hexamethonium, methotrexate
- (iii) Irritant fumes
Smoke, ammonia, sulphur dioxide
- (iv) Uraemia
- (v) Radiation
- 4. Raised intracranial pressure
- 5. Trauma
 - (i) Direct injury to the chest
 - (ii) Blast injury
 - (iii) Thoracic surgery
- 6. Hypoxia - acute high-altitude oedema
- 7. Lymphatic obstruction - mainly carcinomatous
- 8. Hypoproteinaemia - rarely in:
 - (i) Nephrotic syndrome
 - (ii) Hepatic failure
 - (iii) Malabsorption

CONGESTION AND CARDIAC FAILURE

An increased content of blood in an organ or tissue may be an active hyperaemia in response to increased metabolic activity, for example in skeletal muscle, or passive congestion. Passive congestion may result from local venous obstruction and parallels the formation of a transudate, or more frequently it is a consequence of cardiac failure.

Cardiac failure can predominantly involve the right ventricle giving rise to congestion of the abdominal organs together with ascites and peripheral oedema, or involve the left ventricle producing pulmonary congestion and under-perfusion of the systemic circulation. Frequently, both ventricles are involved and a state of congestive cardiac failure results.

Right ventricular failure (RVF)

Causes

1. Secondary to left ventricular failure
2. Pulmonary hypertension
3. Pulmonary embolism
4. Congenital heart disease
 - (i) Atrial septal defect
 - (ii) Pulmonary stenosis

- (iii) Tricuspid anomalies
- 5. Myocarditis
- 6. Myocardial infarction (rare in RVF)

Effects of RVF

1. Liver

- (i) Hepatomegaly
- (ii) 'Nutmeg' appearance due to
 - a. Centrilobular congestion and atrophy of liver cells
 - b. Peripheral fatty change resulting from hypoxia
- (iii) Centrilobular necrosis in severe, acute congestion
- (iv) Centrilobular fibrosis in prolonged (chronic venous) congestion which may link up and give a false impression of cirrhosis. A true 'cardiac' cirrhosis, with regenerative nodules, is rare

2. Spleen

- (i) Mild to moderate splenomegaly
- (ii) Fibrosis of sinusoidal walls
- (iii) Haemosiderin deposition

3. Kidneys

- (i) Congestion
- (ii) Fatty change and/or cloudy swelling due to hypoxia
- (iii) Redistribution of blood flow with a relative increase to the medulla leading to sodium retention
- 4. Oedema of the subcutaneous tissues-mainly in the dependent parts of the body
- 5. Brain

- (i) Congestion
- (ii) Hypoxia

- 6. Ascites due to portal congestion

Left ventricular failure (LVF)

Causes

1. Systemic hypertension
2. Myocardial ischaemia (with or without infarction)
3. Rheumatic heart disease
 - (i) Mitral incompetence
 - (ii) Aortic stenosis or incompetence

4. Calcific aortic stenosis
5. Coarctation of the aorta
6. Congenital heart disease
7. Cardiomyopathy
8. Myocarditis
9. High output states
 - (i) Pregnancy
 - (ii) Severe anaemia
 - (iii) Hypoxia and hypercapnia
 - (iv) Pyrexia
 - (v) Thyrotoxicosis
 - (vi) Hepatic failure
 - (vii) AV aneurysm
 - (viii) Paget's disease
 - (ix) Beri-beri

Effects of LVF

1. Congestive effects in the lungs
 - (i) Pulmonary oedema
 - (ii) Chronic venous congestion
 - a. Capillary congestion
 - b. Mild interstitial fibrosis mainly involving interlobular septa
 - c. Intra-alveolar haemorrhage
 - d. Haemosiderin-laden macrophages ('heart-failure cells')
 - (iii) Pulmonary infarcts (especially in mitral stenosis)
 - (iv) Hydrothorax
2. Effects of hypoperfusion
 - (i) Acute LVF may give rise to infarcts in organs where the blood supply is already compromised by atherosclerosis. They may be found in
 - a. Kidneys
 - b. Brain, particularly in 'watershed' areas
 - c. Large intestine (ischaemic colitis/strictures)
 - (ii) Kidney Decreased blood flow leads to:
 - a. Hypoxia - hydropic vacuolation in tubular epithelium

- b. Diminished glomerular filtration rate resulting in salt and water retention
- (iii) Liver
 - a. Centrilobular necrosis
 - b. Fatty change
- (iv) Brain

Individual cell necrosis in susceptible areas - the cornu ammonis and the Purkinje cell layer in the cerebellum

13. Hypertension

CONTROL OF BLOOD PRESSURE

The general level of the systemic arterial blood pressure is maintained by three mechanisms:

1. Catecholamine production
2. Renin-angiotensin system
3. Aldosterone production - sodium retention

Regulation of the blood pressure against this background of endocrine control is achieved by the baro-receptor mechanism and autonomic nervous system.

1. Catecholamine production

Catecholamines are produced principally by the chromatin cells of the adrenal medulla.

Adrenaline increases:

- (i) Heart rate
- (ii) Cardiac output
- (iii) Systolic blood pressure

Noradrenaline increases:

- (i) Peripheral resistance
- (ii) Both systolic and diastolic pressure

2. Renin-angiotensin system

Renin is an enzyme produced by the juxta-glomerular apparatus

(JGA) in the kidney. It acts on a substrate (angiotensinogen) found

in the α_2 globulin fraction of plasma to form a decapeptide angiotensin I which in turn is hydrolysed by a converting enzyme to the more powerful octapeptide angiotensin II.

Release of renin is stimulated by:

- (i) Reduction in renal perfusion pressure and low glomerular filtration rate
- (ii) Hyponatraemia
- (iii) β -adrenergic stimulation

(iv) Hyperkalaemia

Angiotensin II has the following effects:

- (i) Contracts smooth muscle
- (ii) Stimulates aldosterone secretion
- (iii) Increases blood pressure by stimulating medullary vasomotor and cardiac centres and facilitates the release of adrenaline and noradrenaline
- (iv) Modifies the excretion of water and electrolytes by a direct action on the kidney
- (v) Stimulates thirst by an action on the central nervous system

This system may be opposed by vasodilators generated in a kallikrein-kinin system.

3. Aldosterone production - sodium retention Aldosterone is produced by the zona glomerulosa cells of the adrenal cortex, its main actions are:

- (i) Increases potassium excretion
- (ii) Increases sodium reabsorption, mainly in the distal tubules
- (iii) Produces a metabolic alkalosis by interfering with urinary acidification

Excessive production of aldosterone leads to hypokalaemia and hypernatraemia, with an associated moderate rise in blood pressure. Excessive production can be either primary, or secondary to an increase in renin/angiotensin formation.

Causes

- (i) Primary aldosteronism
 - a. Adrenocortical adenoma with suppression of renin and angiotensin as a consequence of sodium retention (Conn's syndrome)
 - b. Adrenocortical micronodular hyperplasia
 - c. Aldosterone-secreting carcinoma of the adrenal or ovary (very rare)
- (ii) Secondary aldosteronism
 - a. Diuretic therapy with increased Na⁺ loss
 - b. Na⁺ losing renal disease, e.g. chronic pyelonephritis
 - c. Cardiac failure
 - d. Cirrhosis of the liver
 - e. Nephrotic syndrome
 - f. Malignant hypertension
 - g. 'Toxaemia' of pregnancy
 - h. Combination-type contraceptive pill
 - i. Renal artery stenosis
 - j. Renin-secreting tumours of the kidney

k. Bartter's syndrome (hypertrophy of the JGA)

The key role of sodium in hypertension may ultimately be explained by cell membrane alterations leading to changes in ionic fluxes and intracellular sodium concentrations. Such changes have been demonstrated in red blood cells and leucocytes of hypertensive patients and in the vascular smooth muscle cells of hypertensive experimental animals.

Investigation of the majority of patients with hypertension (BP>160/95 mmHg) reveals no underlying primary disease and the condition is termed essential hypertension.

It has been proposed that essential hypertension is an exaggeration of the tendency for blood pressure to rise with age, and that it results from a repeated sequence in which autonomic nervous overactivity results in a small rise in blood pressure and produces changes in the kidney which maintain the raised level and becomes the basis for a further incremental rise.

In about 10% of patients an underlying cause is found and these cases are termed secondary. When the diastolic pressure is in excess of 120 mmHg and there is papilloedema, the hypertension may be designated 'malignant in type' as it carries a poor prognosis. The malignant phase of hypertension is associated with characteristic pathological features.

Possible causes of secondary hypertension are:

A. Renal diseases

1. Parenchymal
 - (i) Chronic pyelonephritis
 - (ii) Acute or chronic glomerulonephritis
 - (iii) Polycystic disease
 - (iv) Amyloidosis
 - (v) Tumours
 - (vi) Hydronephrosis
2. Renal artery stenosis/obstruction
 - (i) Atheroma
 - (ii) Thrombosis/embolism
 - (iii) Fibromuscular dysplasia
 - (iv) Ligatures
 - (v) Pressure from tumours
 - (vi) Dissecting aneurysm
3. Microvascular disease
 - (i) Diabetic nephropathy
 - (ii) Polyarteritis nodosa
 - (iii) Systemic lupus erythematosus

(iv) Henoch-Schönlein syndrome

B. Endocrine

1. Excess corticosteroids

(i) Cushing's syndrome

a. Corticosteroid therapy

b. ACTH therapy

c. Cortical adenoma

d. Cortical hyperplasia

e. Adrenal carcinoma

f. Basophil adenoma of the pituitary

(ii) Primary and secondary hyperaldosteronism (see p. 305)

(iii) Deoxycorticosterone excess due to a defect in 17-hydroxylation

(iv) Adrenogenital syndrome resulting from absence of 11 β -HSD. This leads to excessive production of 11-deoxycorticosterone and 11-deoxycortisol which exert mineralocorticoid effects (see p. 181)

2. Excess catecholamines

(i) Pheochromocytoma - a tumour of chromatin cells. 90% are found in the adrenal medulla: rare sites include sympathetic ganglia around the aorta and inferior vena cava and in the wall of the bladder. These tumours secrete large quantities of noradrenaline/adrenaline

(ii) Treatment with indirect sympathomimetics (amphetamine, tyramine) in combination with monoamine oxidase inhibitors

3. Pituitary causes

(i) Acidophil adenoma giving rise to acromegaly

(ii) Basophil adenoma with excessive ACTH production

4. Renin-producing tumours of the kidney (very rare)

C. Cardiovascular causes

1. Coarctation of the aorta

2. High cardiac output states produce a rise in blood pressure but do not result in the systemic pathological lesions of hypertension (see p. 139)

D. Neurological causes (usually giving a transient or terminal elevation)

1. Raised intracranial pressure

(i) Trauma

(ii) Tumour

(iii) Abscess

(iv) Haemorrhage

2. Lesions of hypothalamus and brain-stem

3. Psychogenic - anxiety state

PATHOLOGICAL EFFECTS OF 'BENIGN' HYPERTENSION

A. Blood vessels

1. Arterioles

(i) Hyalinisation: this is seen in ageing but is accentuated by hypertension. It consists of the accumulation of homogeneous eosinophilic material initially under the endothelium but later replacing the entire wall and occurs in many organs. It is seen most frequently in the kidney (afferent arterioles), spleen, pancreas, and adrenals. The hyaline deposit contains some fibrin, glycoprotein, lipid and cholesterol and is presumed to originate from the plasma

2. Small and medium-sized arteries

(i) Medial muscular hypertrophy and later fibrosis

(ii) Duplication of the elastic lamina

(iii) Intimal proliferation

(iv) Micro-aneurysm formation in the small perforating arteries (less than 1 mm diameter) of the brain, especially in the basal ganglia and subcortical areas. Such aneurysms are found with increasing age, but they are found earlier and in greater numbers in hypertensive patients. There is loss of the muscular media and the wall consists of dilated intima and adventitia. Some micro-aneurysms contain subintimal hyaline deposits which stain for fibrin and fat (lipohyalinosis) and these lesions are particularly prone to rupture

3. Large arteries

Increase in severity of atherosclerosis and its results

B. Kidneys (hypertensive nephrosclerosis)

1. Gross appearances

(i) Normal or reduced size

(ii) Granular surface

2. Glomeruli

(i) Thickening of basement membrane

(ii) Loss of cellularity

(iii) Hyalinisation

3. Bowman's capsule

(i) Deposition of collagen on inside of capsule

(ii) Less frequently, dilatation of Bowman's space and collapse of the glomerulus

4. Tubules

Variable atrophy, with occasional casts.

Most of these changes probably result from ischaemia

C. Heart

1. Left ventricular hypertrophy
2. Increased coronary atherosclerosis
3. Focal myocardial fibrosis

D. Brain

1. Massive intracerebral haemorrhage
2. Perivascular ischaemic atrophy maximal in the globus pallidus
3. Multiple small infarcts
4. Multiple small haemorrhages
5. Microaneurysms

PATHOLOGICAL EFFECTS OF MALIGNANT HYPERTENSION

A. Blood vessels

1. Arterioles

Fibrinoid 'necrosis' of the arteriolar wall in which pyknotic nuclear fragments and red blood cells may be seen. Found in the kidney, pancreas, adrenal, mesentery, brain, eye, heart and liver. Such arteriolar necrosis is also a feature of:

- (i) Systemic lupus erythematosus
- (ii) Polyarteritis nodosa
- (iii) Haemolytic-uraemic syndrome
- (iv) Irradiation

2. Arteries

Endarteritis fibrosa: concentric lamellar connective tissue and mucinous thickening of the intima ('onion-skin' thickening) which narrows the lumen. Also seen in:

- (i) Progressive systemic sclerosis
- (ii) Post-partum acute renal failure
- (iii) Haemolytic-uraemic syndrome
- (iv) Rejection after transplantation

B. Kidney

1. Gross appearances

- (i) Size is variable
- (ii) Smooth surface

- (iii) Subcapsular petechial haemorrhages

2. Glomeruli

- (i) Patchy fibrinoid necrosis of tufts

- (ii) Occasionally complete infarction tufts

3. Bowman's capsule

- (i) Deposition of fibrin in the capsular space

- (ii) Occasional epithelial 'crescent' formation

C. Brain (hypertensive vascular crisis)

1. Gross appearances

- (i) Oedema

- (ii) Petechial haemorrhages

2. Microscopic appearances

- (i) Fibrinoid necrosis of arterioles and small arteries

- (ii) Perivascular cuffing by lymphocytes

PULMONARY HYPERTENSION

The normal pressure in the pulmonary artery is about 15 mmHg. Pulmonary hypertension is characterised by pressures in excess of 30 mmHg.

Causes of pulmonary hypertension

1. Increased pulmonary venous pressure

- (i) Chronic left ventricular failure

- (ii) Mitral stenosis

Rare causes:

- (iii) Left atrial myxoma

- (iv) Cor triatriatum

- (v) Idiopathic thrombosis of pulmonary veins

- (vi) Compression of veins by mediastinal neoplasm

- (vii) Venocclusive disease

2. Increased pulmonary vascular resistance

Obstruction to pulmonary arteries/arterioles

14. Atherosclerosis and aneurysms

Atherosclerosis is a disease which affects the intima of arteries. It appears as focal thickening or plaques composed of fibrous tissue and lipid deposits. Atherosclerosis is not synonymous with arteriosclerosis. The latter term includes a number of diseases characterised by thickening of

arterial vessels:

Classification of arteriosclerosis

1. Intimal thickening with lipid deposition - atherosclerosis
2. Hyaline thickening -- Ageing, diabetes and hypertension
3. Medial fibrosis -- Ageing, diabetes and hypertension
4. Fibrous intimal proliferation
(arteriosclerosis obliterans) -- Hypertension
5. Medial hypertrophy -- Hypertension
6. Medial calcification

PATHOLOGY OF ATHEROSCLEROSIS

This disease is generally considered to pass through three stages, the fatty streak, the fibro-fatty plaque, and the complicated lesion.

1. Fatty streaks in the aortic intima can be found even in the first two decades of life, especially in the aortic valve region, around the ductus scar, and below the intercostal ostia. Some of the lipid is found in endothelial cells overlying the streaks, but the majority is found within foam-cells in the intima. These foam cells arise from two sources: some are lipid-containing smooth muscle cells - 'myogenic' foam-cells, while others are macrophages derived from circulating monocytes. Most of the lipid in these lesions is intracellular and can therefore be mobilised and resorbed under certain circumstances, e.g. a low-lipid diet.
2. Fibro-fatty plaques represent the typical lesion seen in middle and old age. They consist of lipid accumulations, fibro-elastic tissue, and proliferated smooth-muscle cells in the intima.

Earlier lesions contain myogenic foam-cells and a few macrophages in the subendothelial region, but in the later free fat or cholesterol crystals in a central mass of necrotic material. New vessels develop from the vasa vasorum and adventitia and infiltrate the base of the plaque.

3. Complicated lesions. The fibro-fatty plaques can be complicated by:
 - (i) Superimposed thrombosis
 - (ii) Haemorrhage into the plaque from the vasa vasorum
 - (iii) Rupture and ulceration with discharge of necrotic debris
 - (iv) Calcification

Arterial structure

In order to understand the various theories of pathogenesis, the normal structure and the physiological pressure effects acting on large arteries must be understood.

1. Structure of a large artery
 - (i) Endothelium has a structure similar to that found in capillaries and is freely permeable to fluid and electrolytes. It also allows slow leakage of large molecules, e.g. protein and lipoproteins, from the plasma into the intima

- (ii) A thin layer of loose fibro-elastic tissue lies between the endothelium and internal elastic lamina. It becomes thicker with age and shows a gradual increase in its content of smooth muscle cells. This layer together with the endothelium constitute the intima of the vessel.

- (iii) The media is composed of collagen fibres, elastic tissue and smooth muscle cells. Its main function is to resist the expansive force of the blood pressure, and convert a pulsatile to a continuous flow

- (iv) The outermost layer consists of loose fibrocellular tissue - the adventitia. It contains nerve fibres, lymphatics and small nutrient arteries associated with the vessel wall

- (v) Extracellular matrix (ground substance) fills the interstices of the wall and is most abundant in the intima. It binds or retards larger molecules passing through the wall, thus acting as a fine pored filter, and is composed of glycosaminoglycans, glycoproteins and proteoglycans

- (vi) The vasa vasorum are the small blood vessels which enter from the adventitia and supply the outer 2/3 of the wall

2. Pressure effects on the wall

Blood flow exerts shearing stresses on the wall which tend to displace the endothelium and the inner layers of the wall in the direction of flow. In addition arterial walls are subjected to a considerable compressive force amounting, for example, to about 50 kg/cm² in the aorta. This compressive force is gradually converted into a tangential force (tensile stress) by the elastic laminae and muscle fibres of the media. The vasa vasorum can only nourish those parts of the wall where the intramural compressive force is equal to or less than the capillary blood pressure, and such conditions are found only in the outer 2/3 of the wall. The intima and inner part of the media are nourished entirely by diffusion of plasma from the lumen. There is a considerable flow of plasma into the wall and this leaves via the lymphatics and veins of the vasa vasorum.

LIPOPROTEINS

The plasma lipids are almost entirely bound to certain proteins within composite molecules known as lipoproteins.

Each can be considered as a protein fraction - the apoprotein, bound to a variety of different lipids - cholesterol, cholesterol esters, phospholipids, and triglycerides (TG).

Lipoproteins are generally classified according to their ultracentrifugation properties and have been divided into high-density (HDL), low-density (LDL) and very low-density (VLDL) lipoproteins. These categories correspond to the (a, b, and pre-b-lipoproteins recognised electrophoretically. In addition triglyceride-rich lipoproteins are formed and packaged within intestinal mucosal cells and enter the circulation as chylomicrons. More recently other transport forms, chylomicron remnants, and VLDL remnants (termed intermediate density lipoproteins - IDLS), have been described.

Composition of plasma lipoproteins:

1. Chylomicrons - triglyceride and apoA-I, II, IV and apoB-48
2. VLDL - triglyceride, phospholipid and apoB-100, apoC-I, II, III and apoE
3. IDL - esterified cholesterol, phospholipid, apoB-100 and apoE
4. LDL - triglyceride, esterified cholesterol and apoB-100

5. HDL - phospholipid, cholesterol, apoA-I, II, apoC-II and apoE

Chylomicrons carry dietary TG to adipose and muscle cells where they become attached to a membrane-bound enzyme, lipoprotein lipase, on the surface of endothelial cells. The lipase liberates FFAs and monoglycerides from the triglyceride core and the chylomicron remnants re-enter the circulation, attach to receptors on liver cells, and following endocytosis are broken down by lysosomal action. In a similar fashion, VLDL manufactured by the liver from newly synthesised TG, proteins, and cholesterol (which has usually been recycled), are acted upon by lipoprotein lipase and liberate VLDL remnants which are termed intermediate density lipoproteins. IDL acquire more cholesterol esters derived from the action of plasma lecithin-cholesterol acyltransferase (LCAT) on the circulating HDL pool, and are thereby converted into particles made up almost entirely of a cholesterol ester core and an apoprotein coat. These particles constitute the LDLs which, in normal subjects, account for about two-thirds of the total plasma cholesterol.

LDLs are disposed of in two ways:

1. via high-affinity specific receptors
2. via non-specific macrophage activity

1. *Receptor-mediated disposal*

LDL receptors are present on liver and extra-hepatic cells. Once bound to the cell surface, the lipoprotein is internalised and undergoes lysosomal degradation. Liberated cholesterol is utilised for membrane building or steroid synthesis, or is passed back to the HDL pool. Plasma LDL concentration increases with age, probably as a result of an acquired defect in LDL receptor function.

2. *Macrophage activity*

Where there is a high plasma level of LDL, or some local build-up, macrophages will absorb and degrade lipoprotein and accumulate cholesterol esters in their cytoplasm

The major ligand for the LDL receptor and the chylomicron remnant receptor is apoprotein E. This arginine rich protein is also associated with VLDLs and is the ligand that promotes their interaction with macrophages leading to cholesterol ester storage. Apoprotein E is involved in the transformation of VLDLs to particles of LDL size and density, and the removal of VLDLs from the circulation.

SMOOTH MUSCLE CELLS

Arterial smooth muscle cells are largely responsible for the tensile strength and the structural integrity of the wall by the synthesis of extracellular matrix and the cells vary considerably in the degree to which they manifest these 'contractile' or 'synthetic' activities. Thus, during development arterial smooth muscle cells switch from a predominantly synthetic role in the fetus to a contractile state in the adult but can readily reverse this pattern following damage to the arterial wall. The synthetic phenotype has several noteworthy differences to the contractile phenotype. Synthetic cells:

- (i) Do not contract
- (ii) Migrate and proliferate following stimulation by macrophage- derived growth factors

(iii) Synthesise and secrete PDGF which acts in an autocrine fashion to further stimulate proliferation

(iv) Show increased:

- a. Collagen synthesis
- b. Degradation of VLDL
- c. Lysosomal enzyme activity, except cholesterol esterase

(v) Show diminished:

- a. Degradation of LDL
- b. Acid cholesterol esterase activity

(vi) Accumulate cholesterol

MACROPHAGES AND ATHEROSCLEROSIS

Macrophages are not normally present within the arterial wall but are a prominent feature of atherosclerosis. Just as in the inflammatory response monocytes attach to endothelial cells expressing adhesion molecules. Endothelial expression of ICAM-1 occurs in atherosclerosis and monocytes adhere via their b-2 integrin receptor and penetrate the endothelium. Once in the intima, monocytes transform into functional macrophages and by producing TNF and IL-1 increase endothelial synthesis of adhesion molecules and encourage more monocyte emigration.

Such emigration is further stimulated by the production of cytokines with monocyte chemotactic properties by intimal macrophages in a positive feedback loop.

Macrophages produce PDGF and other cytokines which promote the proliferation of smooth muscle cells. They also ingest oxidised LDLs present in the intima and are converted into foam cells. Thus, both macrophages and smooth muscle cells accumulate lipid in atherosclerosis and can appear as foam cells.

RISK FACTORS IN ATHEROGENESIS

On the basis of epidemiological studies the following major risk factors have been identified:

1. Age
2. Sex
3. Obesity
4. High dietary cholesterol intake
5. Cigarette smoking
6. Hypertension
7. Diabetes mellitus
8. Hyperlipidaemia
9. Low HDL level

PATHOGENESIS OF ATHEROSCLEROSIS

The following factors have been claimed to be responsible in some measure for the development of atherosclerosis:

A. Lipid accumulation

Supporting evidence

1. Increased atherosclerosis in hyperlipidaemia states. The more common types associated with an increased risk are:
 - (i) Type IIA - Familial hyper-b-lipoproteinaemia (high LDL)
 - (ii) Type IIB - Over-indulgence hyperlipidaemia
 - (iii) Type IV - Endogenous hypertriglyceridaemia (raised VLDL)
2. Increased atherosclerosis in hypercholesterolaemia resulting from primary (familial) or secondary deficiency of LCAT
3. Increased atherosclerosis where there is a high level of lipoprotein-A, a distinct member of the LDLs which may prevent normal uptake and disposal of other LDLs. This lipoprotein also has plasminogen-like effects and may compete for plasminogen binding sites and inhibit fibrinolysis
4. Production of fatty plaques in experimental animals by feeding with a high cholesterol diet
5. Analysis of atheromatous plaques reveals 10 or more times the normal lipid content of the intima. The increase is made up predominantly of cholesterol linoleate derived from LDLs.
6. High HDL levels protect against coronary atherosclerosis probably by inhibiting macrophage production of monocyte chemoattractants.

Possible mechanisms

1. Excess low density lipoproteins (especially lipoprotein-A) in the plasma
2. Altered permeability of the endothelium allows more plasma lipids to enter the wall
3. Retention of lipoproteins in the intima resulting from altered filtration characteristics of the ground substance
4. Defective metabolism of the smooth muscle cells leads to saturation of the lysosomal lipoprotein disposal system. This may result from:
 - (i) congenital hydrolytic enzyme deficiency
 - (ii) acquired relative deficiency as in diabetes mellitus
 - (iii) effects of viral infection (see below)
5. Leakage from newly-formed vasa vasorum in fibro-fatty plaques

Effects

1. Alteration in the ground substance
2. Proliferation of smooth muscle cells - frequently monoclonal
3. Accumulation of 'foam-cells'

4. Increase in connective tissue fibres
5. Necrosis and inflammation in advanced lesions - the necrogenic effect of lipids

B. Haemodynamic stress

Supporting evidence

1. Association with systemic hypertension
2. Increased severity in coronary arteries where there is cyclical reversal of flow
3. increased incidence and severity at sites of branching where there is a relatively low flow velocity and oscillating wall shear stress
4. Absence from veins and minimal involvement of the pulmonary circulation (except where there is pulmonary hypertension)

Effects of stress

1. Low and oscillating shear stresses may weaken interendothelial cell junctions so that there is greater ingress of lipids into the intima
2. Low shear stresses encourage the attachment of platelets, monocytes and polymorphs to endothelial cells. The former may initiate surface micro-thrombosis while the latter may alter vascular permeability or increase the rate of monocyte entry into the intima.
3. Polymerisation of the ground substance which alters its filtration characteristics
4. Formation of new collagen and elastin fibres
5. Intimal thickening resulting from the connective tissue and smooth muscle cell proliferation
6. Rupture of the elastic lamina

C. Organisation of surface thrombosis

supporting evidence

1. The microscopic appearances of an organised mural thrombus and an atheromatous plaque can be identical
2. Deposition of fibrin and platelets on vascular endothelium is a frequent event
3. Atheromatous plaques contain large quantities of fibrinogen, fibrin, and platelets
4. Hyperlipidaemic states are associated with a decreased clotting time and impaired fibrinolysis

Probable mechanisms

1. Endothelial injury results in surface microthrombosis
2. Lipoproteins may prevent initial access and binding of plasminogen to the deposited fibrin thereby blocking lysis
3. Re-endothelialisation increases the rate of entry of LDLs into the organising thrombus by micropinocytosis
4. Fibrin degradation products stimulate smooth muscle cell proliferation in the intima

D. Viral infection

supporting evidence

1. Herpes viruses can be found in the arterial wall
2. Atherosclerosis can be induced in normocholesterolaemic animals by herpes viruses
3. Herpes virus infection of smooth muscle cells in vitro leads to inactivation of cholesterol ester hydrolase and accumulation of free and esterified cholesterol
4. Endothelial infection by herpes simplex virus leads to increased synthesis and expression of glycoprotein C which can act as a binding site for Factor X and initiate blood coagulation
5. Herpes viruses can induce the synthesis of cytokines which act as growth promoters for cells within the vessel wall
6. Cytomegalovirus infection following cardiac transplantation can lead to accelerated atherogenesis

Probable mechanisms

1. Initial binding of herpes simplex virus to heparan sulphate is followed by attachment to endothelial and smooth muscle cells via their FGF receptors
2. Entry of virus into endothelial cells is followed by lethal injury and cellular desquamation or sublethal cytopathic effects
3. Desquamation results in exposure of collagen which leads to platelet aggregation
4. Sublethal injury leads to enhanced platelet binding to endothelium, diminished PG[2] production and reduced synthesis of heparan sulphate which normally acts as a surface anticoagulant. These effects promote thrombosis in the area of endothelial infection
5. The damaged endothelium also releases growth factors and cytokines which stimulate smooth muscle proliferation
6. Infection of smooth muscle cells leads to altered metabolic activity in which there is increased binding of LDL cholesterol esters coupled with decreased cholesterol ester (CE) hydrolysis resulting in accumulation of CE-enriched lipid droplets

Multifactorial causation

1. Endothelial injury is likely to be the initial event
2. Injury probably results from haemodynamic stress but may also be related to toxins (? nicotine, carbon monoxide), metabolites, or viral infection
3. Endothelial injury or inflammation promotes Polymorph, monocyte and platelet adhesion. Increased numbers of monocytes may enter the intima where they produce cytokines that amplify cellular emigration
4. Dietary fatty acids may influence platelet-vessel wall interactions by modulating the balance between prostacyclin and thromboxane synthesis. Platelet aggregation then leads to surface thrombosis
5. Smooth muscle cells are stimulated by macrophage-derived growth factors including PDGF

and switch to a synthetic phenotype. The cells proliferate and secrete increased amounts of proteoglycans and collagen

6. The proteoglycans in the matrix favour the entrapment of apo B containing lipoproteins and the resulting lipid-rich complexes and oxidised LDLs are taken up by macrophages
7. Altered endothelial permeability, matrix trapping and defective lysosomal disposal lead to an accumulation of LDLs in the intima
8. The rate and extent of LDL accumulation is modified by the plasma lipoprotein levels

EFFECTS OF ATHEROSCLEROSIS

1. Progressive occlusion leading to ischaemia
2. Infarction resulting from sudden occlusion due to
 - (i) Superimposed thrombosis
 - (ii) Haemorrhage into plaque
3. Rupture of a plaque leading to micro-embolisation by atheromatous debris
4. Aneurysm formation

ANEURYSMS

An aneurysm is a localised dilatation of an artery or part of the heart consequent upon weakening of its wall.

1. Large and medium-sized arteries. Aneurysms may result from:
 - (i) Atherosclerosis. This is the commonest cause. Secondary weakening of the media gives rise to fusiform or saccular dilatations usually in the abdominal portion of the aorta
 - (ii) Congenital defects. A congenital deficiency of the media and elastica in cerebral arteries leads to 'berry' aneurysm formation
 - (iii) Cystic medionecrosis. In this disorder there is focal loss of elastin and accumulation of acid glycoproteins in the media with subsequent cystic degeneration and splitting of the vessel giving rise to a 'dissecting aneurysm'. Dissecting aneurysms also occur in Marfan's syndrome.
 - (iv) Trauma, especially in arteries of the legs
 - (v) Syphilis. The mesaortitis of tertiary syphilis can lead to aneurysms in the thoracic aorta
 - (vi) Polyarteritis nodosa
 - (vii) Infection of the vessel wall by bacteria brought there by infected emboli giving rise to 'mycotic' aneurysms, e.g. in bacterial endocarditis
2. Small arteries. Microscopic dilatations of small arteries (microaneurysms) which predispose to rupture are found in:
 - (i) Systemic hypertension, in small intracerebral arteries
 - (ii) Pulmonary hypertension, as dilatation lesions in muscular arteries
 - (iii) Diabetic retinopathy
3. Heart. Ventricular aneurysms may complicate myocardial infarction



micro.current.cranial.electro.stimulation

CE MICES

for autism

If you need more information on the SCIO and purchase details please get in touch with us

Maitreya Kft.

tel: +3613036043 | web: www.qxsubspace.com | e-mail: info@qxsubspace.com



It is scientific fact that when a low level voltage and micro-current pulse is applied to the body osmosis, enzyme activity, and healing are increased. The SCIO will let the patient's body electric autofocus a harmonic pulse to maximize this effect. This current applied to the cranium has been shown to help autism, attention deficit and hyperactive children. It has been shown helpful for anxiety, addictions, emotional disturbances, and insomnia.

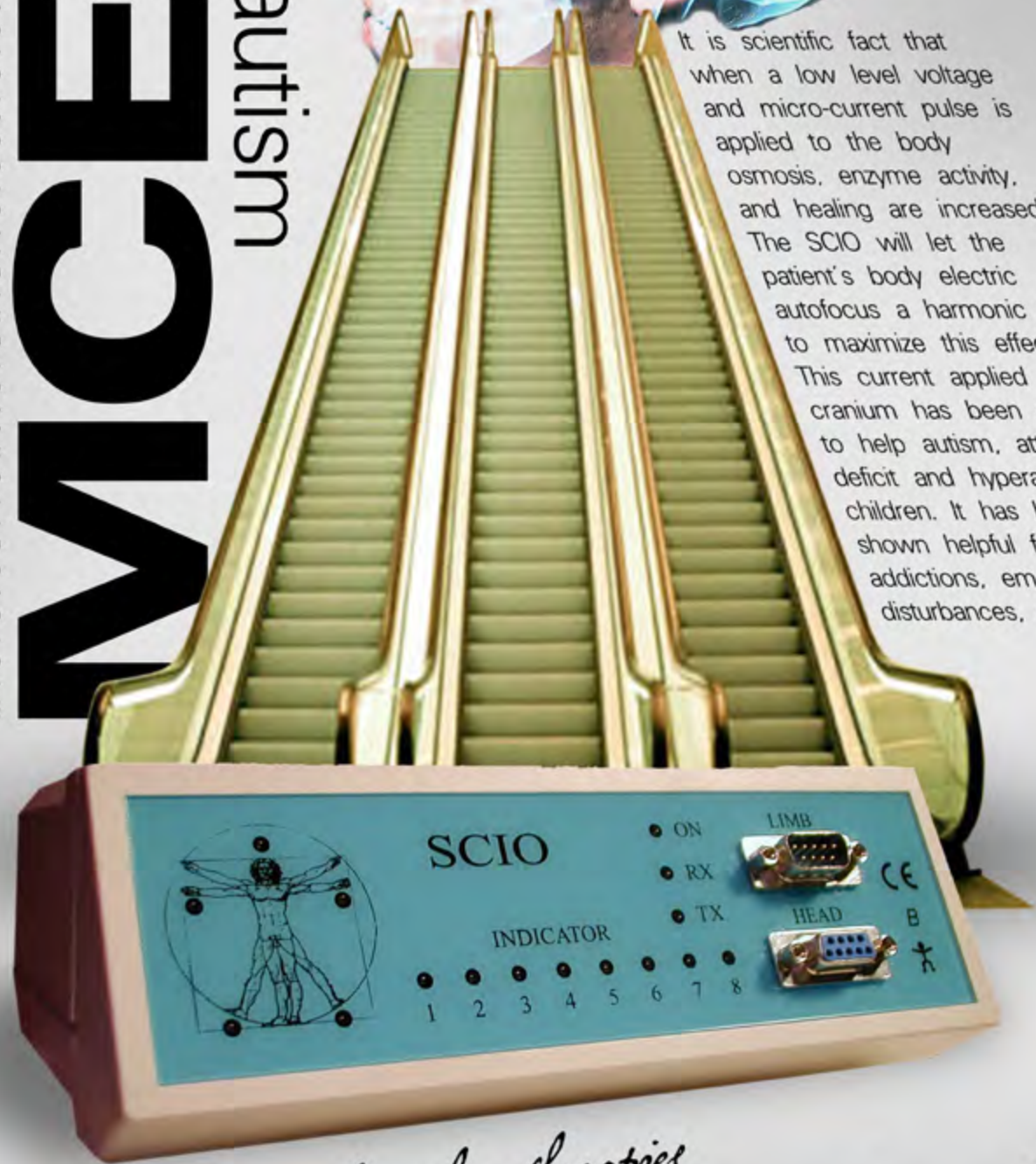

*There is published research on these therapies
The new world of energetic medicine can help you*

15. Thrombosis, embolism, and infarction

Thrombosis is the formation of a solid mass from the constituents of the blood within the vascular system during life. The solid (or semi-solid) mass is called a thrombus.

CAUSES OF THROMBOSIS

These are best considered under the three headings originally proposed by Virchow in 1856:

- A. Changes in the vessel wall
- B. Changes in blood flow
- C. Changes in the constitution of the blood

A. Changes in the vessel wall

1. Arteries
 - (i) Atherosclerosis
 - (ii) Inflammation
 - a. Direct involvement in wall of an abscess, ulcer, etc.
 - b. Auto-immune or drug induced
 - c. Polyarteritis nodosa
 - d. Giant-cell arteritis
 - e. Thromboangiitis obliterans
2. Veins
 - (i) Inflammation (thrombophlebitis) resulting from
 - a. Trauma - fractures, tourniquets, i.v. catheters
 - b. Chemical injury - e.g. sclerosing fluids for treatment of varicose veins and haemorrhoids, irritant fluids administered intravenously
 - c. Bacterial infection, e.g. thrombophlebitis of venous sinuses complicating acute suppurative otitis media or mastoiditis

B. Changes in blood flow

1. Arteries
 - Stasis and/or turbulence related to
 - (i) Aneurysms
 - (ii) Atherosclerotic plaques
 - (iii) Spasm
2. Veins
 - (i) Local causes

- a. Inactivity. Lack of muscular 'pumping' action greatly reduces venous flow
- b. Pressure on veins by ill-fitting plasters, bandages, gravid uterus, tumours, etc.
- c. Dilatation and valvular incompetence, e.g. in varicose veins

(ii) General factors

- a. Congestive cardiac failure
- b. Circulatory collapse following severe trauma, burns, etc.

C. Changes in the constitution of the blood

1. Increased viscosity associated with erythraemia (or polycythaemia) promotes thrombosis in arteries and veins.

Causes:

- (i) Dehydration, particularly in infancy leading to renal and cortical vein thrombosis
 - (ii) Chronic hypoxic states, e.g. respiratory failure, cyanotic congenital heart disease
 - (iii) Polycythaemia rubra vera
2. Increased viscosity resulting from high plasma protein content, e.g. multiple myeloma
 3. Hypercoagulable states found
 - (i) Following major surgery or trauma
 - (ii) In pregnancy and parturition
 - (iii) In some users of the oral contraceptive pill
 - (iv) In some cases of leukaemia and polycythaemia rubra vera due to thrombocytosis
 - (v) After splenectomy
 - (vi) In endotoxaemia, shock, hypersensitivity reactions
 - (vii) In association with some tumours, e.g. carcinoma of the pancreas

STEPS IN THE FORMATION OF A THROMBUS

1. Adhesion of platelets to exposed collagen at the site of endothelial damage. Adhesion is mediated by fibronectin on the surface of platelets and is stimulated more by Type III collagen than basement-membrane collagen
2. Secretion of adenosine diphosphate (ADP) and thromboxane A₂ by the adherent platelets
3. ADP and thromboxane induces platelet aggregation
4. Activation of blood coagulation by:
 - (i) The intrinsic pathway ('intrinsic' because all the necessary factors are already present in the blood) is initiated by collagen activation of Factor XII and facilitated by platelet phospholipid (Factor III) which is present on the surface of the aggregates
 - (ii) The extrinsic pathway initiated by tissue thromboplastins derived from damaged endothelial cells, etc. The final common pathway leads to thrombin formation which in addition

to converting fibrinogen to fibrin causes further ADP and thromboxane release from platelets thus promoting aggregation. The aggregates are stabilised by the deposited fibrin

5. The rough surface of the developing thrombus acts as a stimulus for further platelet adhesion which is followed by deposition of another layer of fibrin and entrapped red blood cells

In this way, a laminated mass composed of alternating layers of platelet (pale) thrombus, and fibrin with enmeshed red blood cells (red thrombus) is built up. The irregular pale laminae are sometimes visible to the naked eye and are termed lines of Zahn. Once complete occlusion of the vessel has occurred, the static blood beyond the thrombus may undergo coagulation. Here coagulation is not occurring in circulating blood, and a homogeneous red clot is produced. In veins, the tail of this clot may reach a tributary vessel in which there is flowing blood and initiate a fresh thrombus. In this way, occlusion of small veins by thrombus and blood clot may extend proximally into major veins, a process termed propagation.

VENOUS THROMBOSIS

Venous thrombosis is much more common than thrombosis in arteries. It is increasing in frequency and is apparently related to the general prosperity of the population, being much less common in underdeveloped countries. The explanation for this might lie in differences in diet, in levels of activity, in longevity and in the number of surgical operations performed. Many thrombi are clinically 'silent'.

Factors implicated in venous thrombosis (phlebothrombosis)

1. Surgical operations. Thrombosis is common after operations.
 - (i) General effects, e.g. splenectomy
 - (ii) Local effects, e.g. gynaecological and hip operations
 - (iii) Loss of muscle 'pump' and direct pressure on veins during anaesthesia
 - (iv) Immobilisation, especially in orthopaedic cases
2. Congestive cardiac failure and myocardial infarction. These are associated with venous stasis and immobilisation
3. Age. Thrombosis increases with age
4. Pregnancy
 - (i) Hypercoagulable state
 - (ii) Pressure on pelvic veins by gravid uterus
5. Oral contraceptive pill - high oestrogen type
6. Obesity
7. Malignancy, e.g. carcinoma of pancreas, possibly related to production of thromboplastins by the tumour cells

Location

1. Deep veins of the calf
2. Iliofemoral segment by propagation from the calf or arising de novo

- Multiple sites simultaneously

Most venous thrombi are thought to originate in or close to a valve pocket.

Special varieties of venous thrombosis

- Thrombophlebitis - thrombosis secondary to inflammation of the vein wall
- Thrombophlebitis migrans
 - Recurrent thrombosis at different sites
 - Typically involves limb veins
 - Often associated with visceral malignancy (Trousseau's sign)
- Phlegmasia alba dolens - 'painful white leg of pregnancy' thrombosis of the femoral and external iliac veins together with arterial spasm
- Mondor's disease - localised phlebitis affecting subcutaneous veins of the abdominal or thoracic wall, especially around the breast

ARTERIAL THROMBOSIS

Factors implicated in arterial thrombosis

- Damage to the endothelial lining, e.g. atherosclerosis, trauma
- Micro-turbulence around irregular atheromatous plaques
- Major disturbances of flow in aneurysms or due to sustained spasm

Types of thrombus

- Occluding thrombus in medium and small arteries frequently in association with concentric atherosclerosis
- Thrombosis occurring over part of the wall of a large artery or the aorta - mural thrombosis

CARDIAC THROMBOSIS

Factors implicated in intracardiac thrombosis

- Endocardial damage resulting from
 - Underlying myocardial damage as in myocardial infarction
 - Primary endocardial inflammation as in acute rheumatic fever
 - Haemodynamic factors in chronic valvular disease with resultant mechanical injury
- Disordered myocardial contraction, e.g. intra-atrial thrombosis resulting from atrial fibrillation
- Turbulence, as in a ventricular aneurysm following myocardial infarction

Types of cardiac thrombosis

1. Valvular thrombosis

Thrombi composed of platelets, fibrin and variable numbers of red blood cells formed on the valve cusps are termed vegetations. They are found in:

- Acute rheumatic fever. The vegetations (which are composed almost entirely of platelets) are small, compact, firm and rubbery
- Infective endocarditis. This condition affects valves previously damaged by rheumatic fever or congenitally abnormal valves, e.g. bicuspid aortic valve. The vegetations are large, friable, and contain the infective agent, e.g. bacterial 'colonies' or more rarely, rickettsia, fungi and yeasts
- Non-infective ('abacterial') thrombotic endocarditis. Known for many years as Lamb's excrescences, these sterile vegetations are found with increased frequency in patients with wasting diseases, particularly carcinomatosis. They are of variable size and may break off giving rise to cerebral infarction
- Verrucous endocarditis (Libman-Sacks) found in some cases of systemic lupus erythematosus

2. Mural thrombosis

Thrombosis adherent to part of the endocardial lining is found in:

- Myocardial infarction which can result in inflammation of the endocardium and subsequent thrombosis
- Rheumatic fever, MacCallum's patch in the left atrium resulting from mitral regurgitation
- Acute myocarditis

3. Ball thrombus

A detached, ovoid or spherical thrombus may be formed in the atria in atrial fibrillation. This can impact in the mitral ring and produce a syncopal attack or even sudden death. More commonly, atrial fibrillation is associated with thrombosis in the atrial appendage or a polypoid thrombus attached to the wall.

1. Resolution

The thrombus may be completely removed by a combination of

- Shrinkage by a process analogous to clot-retraction in vitro
- Platelet autolysis
- Fibrinolysis brought about by:
 - Binding of the circulating proenzyme plasminogen and plasminogen activator (released by vascular endothelium) to fibrin
 - Generation of plasmin, a powerful proteolytic enzyme which if not bound to fibrin is inactivated by plasma (α₂-antiplasmin)
 - Degradation of fibrin by plasmin with release of fibrinopeptides (fibrin degradation products) into the circulation

(iv) Phagocytosis by macrophages which infiltrate the thrombus

2. Organisation

Ingrowth of endothelial cells, fibroblasts and smooth muscle cells convert the thrombus into fibrovascular tissue rich in collagen and elastin fibres.

(i) In occluding thrombi continuity of newly-formed vascular channels may be established and their subsequent dilatation lead to partial restoration of blood flow - a process known as recanalisation

(ii) In mural thrombi the surface becomes re-endothelialised and the organised thrombus eventually becomes a fibrous plaque which may be indistinguishable from an atherosclerotic lesion

3. Detachment

A portion of a friable or loosely attached thrombus may break off into the circulation forming an embolus.

EMBOLISM

Embolism is the impaction in part of the vascular system of any abnormal undissolved material carried there by the blood stream. The recognised types are:

1. Thrombi
2. Fat emboli
3. Gaseous embolism
4. Tumour fragments
5. Infective agents
6. Atheromatous material
7. Amniotic fluid
8. Foreign bodies

1. Thrombi

These are by far the commonest type. The detached thrombus may be of venous, arterial, or cardiac origin.

Venous thrombosis in the leg or pelvic veins may lead to embolism to the pulmonary arteries. The possible results are:

- (i) Sudden death after obstruction by major embolism. Death results from
 - a. Systemic anoxia
 - b. Acute right ventricular failure
 - c. ? Liberation of 5-HT causing spasm of the pulmonary arterial system
 - d. ? Reflex vagal inhibition

(ii) Ischaemic necrosis of lung tissue - infarction. In the lung, infarcts are haemorrhagic because of the dual blood supply (via pulmonary and bronchial arteries)

(iii) Progressive obliterative pulmonary hypertension from multiple microemboli

(iv) Splits in the wall and aneurysms in the proximal pulmonary artery following acute stretching

Arterial and cardiac thrombosis The main sites are:

(i) Mural thrombus in the left ventricle

(ii) Thrombus on atheromatous lesions in the aorta and major branches

(iii) Vegetations on valves

(iv) Atrial thrombus Detachment results in:

(i) Lodgement in end-arteries, e.g. in brain, kidneys, spleen, retina, etc.

(ii) Arterial occlusion leading to gangrene of the intestine or limbs

(iii) Large embolism lodging across the aortic bifurcation I saddle' embolus, producing ischaemic changes in the lower limbs

2. Fat embolism

Is the impaction of large fat globules in small arteries and capillaries. It differs from thromboembolism in that the globules are fluid and deformable and so occlusion may be temporary or incomplete.

Causes of fat embolism

(i) Fracture of long bones is the major cause

(ii) Operative manipulation of fractures, e.g. in arthroplasty

(iii) Trauma to adipose tissue (rare)

(iv) Trauma to a fatty liver (very rare)

Sites and effects

(i) Pulmonary fat embolism

a. Minor degrees probably have little significance

b. More marked embolism is associated with hypoxaemia which may result from shunting of blood through pre-capillary anastomoses. Such shunting can also give rise to systemic embolism

(ii) Systemic fat embolism is never found in the absence of pulmonary embolism. The most important site for impaction is the cerebral vasculature. This produces multiple small haemorrhagic and ischaemic lesions particularly in the white matter which may lead to coma and death. Multiple petechiae may be found in the skin.

Origin of fat emboli

(i) Disruption of fat cells releases globules of fat into the marrow veins, which then pass to the lungs

(ii) ? Large fat globules form by fusion of chylomicrons under the influence of platelet factors released following trauma

3. Gaseous embolism Causes

- (i) Mismanaged intravenous infusions, especially with infusion pumps
- (ii) Operations in which large veins are opened
- (iii) Air injections for radiological techniques
- (iv) Insufflation of the Fallopian tubes
- (v) Criminal abortion
- (vi) Caisson disease or decompression sickness (nitrogen bubbles forming as a consequence of rapid decompression)

Effects

- (i) Sudden death as a result of a large volume of air reaching the right ventricle and preventing the propulsion of blood into the pulmonary artery
- (ii) Sudden decompression leads to tissue damage by bubble formation especially in the CNS ('divers's bends') and aseptic necrosis of bone resulting in osteoarthritis

4. Tumour fragments

Vascular invasion is a common finding in malignant neoplasms, and clumps of tumour cells may detach and impact at some distant site. Whilst this may be a source of secondary tumours such embolism is rarely large enough to produce ischaemic damage. An exception is renal carcinoma where growth into the renal vein may give rise to relatively large tumour emboli.

5. Infective agents

- (i) Bacterial clusters, e.g. from infective endocarditis giving rise to pyaemic abscesses or 'mycotic' aneurysms
- (ii) Parasites, e.g. clumps of plasmodia in cerebral malaria

6. Cholesterol embolism

Rupture of the thin fibrous cap over a soft atherosclerotic plaque may lead to release of granular lipidic debris into the artery. Many cases arise following medical interventions, such as aortic surgery, aortography, cardiac catheterisation and angioplasty, but spontaneous emboli can occur in patients with severe aortic atheroma. Depending upon the site of origin and size, such embolism can give rise to:

- (i) Myocardial infarction or multifocal necrosis (coronary arteries)
- (ii) Livedo reticularis in skin of the lower limbs
- (iii) Splinter haemorrhages of the nails
- (iv) Cerebral or spinal cord infarction
- (v) Multifocal renal infarction
- (vi) Acute pancreatitis
- (vii) Intestinal infarcts or strictures

7. Amniotic fluid

Fluid may be driven through the placental bed into the maternal circulation during labour, particularly where there is obstruction.

Effects

- (i) Acute respiratory distress and shock which may be fatal
- (ii) Disseminated intravascular coagulation produced by thromboplastins in the fluid
- (iii) Afibrinogenaemia following plasmin activation

8. Foreign bodies

This is rare, but an important example is embolism of Polythene catheters used in intravenous infusions which may break off and lodge in the heart.

Paradoxical embolism

Is defined as the passage of an embolism from the right to the left side of the heart through a septal defect (with a right to left shunt) resulting in systemic arterial embolism from a venous source.

INFARCTION

An infarct is an area of tissue necrosis resulting from ischaemia (deprivation of blood supply). Infarcts therefore arise from arterial occlusion by either thrombosis, embolism, or as a complication of atherosclerosis.

Whether or not an infarct follows arterial blockage depends upon:

1. The size of artery occluded - occlusion of a single small vessel may not give rise to tissue necrosis
2. The collateral circulation - organs with a dual blood supply (e.g. liver) rarely suffer infarction
3. The general state of the circulation - when the circulation is already impaired as a result of congestive cardiac failure, the effects of arterial occlusion may be exacerbated. For example, although the lungs have a dual blood supply (pulmonary and bronchial arteries), occlusion of a pulmonary artery in a patient with chronic venous congestion will lead to infarction.

Major sites

The major sites of infarction are:

1. Myocardium - resulting from atherosclerosis and its complications in the coronary arteries
2. Brain - resulting from
 - (i) Systemic embolism by
 - a. Detached thrombus from the left side of the heart
 - b. Vegetations from the aortic or mitral valves
 - (ii) In situ thrombosis Of a cerebral artery
3. Lungs - resulting from impaction in the pulmonary arterial tree of a thrombo-embolus

formed in the leg or pelvic veins

4. Kidneys, spleen, or intestines - resulting from systemic thromboembolism or from atherosclerosis and its complications in the supplying arteries

Events in an infarct

1. Necrosis, which may be:
 - (i) Coagulative in a solid organ such as the heart, kidney, or spleen
 - (ii) Colliquative in the brain
 - (iii) Haemorrhagic in the lung
2. An inflammatory response provoked by tissue breakdown products such as membrane fragments, denatured proteins, released enzymes, etc. This is manifest as a surrounding rim of hyperaemia and neutrophil polymorph infiltration
3. Demolition of dead tissue by macrophages
4. Organisation - ingrowth of fibroblasts and endothelial cells
5. Scar formation. Even in organs capable of regeneration, this is always very limited after infarction, and a fibrous scar is the usual end result.

Gangrene

This is a special form of infarction where the dead tissue is infected with putrefactive organisms.

Varieties:

1. 'Dry gangrene' - a term usually applied to ischaemic necrosis in a limb. To be precise, this should not be referred to as gangrene as it is not super-infected with putrefactive
2. proper term is 'mummification' but this is rarely used.
3. 'Wet' gangrene - this is where there is super-infection, e.g. in infarcts of the intestine.
4. Gas-gangrene - where the putrefactive organisms produce gas which collects as 'bubbles' in the affected tissues. The organisms are almost always of a clostridia species.

16. Congenital and inherited disorders

DEFINITIONS

A congenital disease or abnormality is one present from birth which may or may not be genetic.

An inherited disease results from genetic factors but may not become apparent until adulthood.

A genetic disorder can be either inherited or mutational.

Congenital malformations are primary defects in body structure resulting from an error in morphogenesis. They are to be distinguished from deformations which are alterations in shape and/or structure of a previously normally formed part, e.g. congenital torticollis, congenital postural scoliosis, talipes (deformities of the feet), etc.

GENETIC DISORDERS

A. Chromosome abnormalities

1. Non-disjunction - failure of a chromosome pair to separate during the formation of gametes by meiosis means that one gamete receives both chromosomes and the other none
2. Translocation - also occurs during meiosis when one of a chromosome pair (or part of a chromosome) fuses to another to form a large composite chromosome
3. Deletion - loss of the whole, or part, of a chromosome during meiosis

In addition, non-disjunction and deletion can occur during the early mitotic divisions after fertilisation and give rise to mosaics, individuals possessing two or more populations of cells having a different chromosomal make-up.

Chromosome abnormalities may affect both the sex chromosomes and the autosomes, although absence of an autosome is almost always lethal.

Sex chromosome abnormalities

These are almost invariably the result of non-disjunction and include:

1. Klinefelter's syndrome - XXY
 - (i) Testicular hypoplasia
 - (ii) Sterility
 - (iii) Mental subnormality

There are clinically similar cases who prove to be 46XY. Here the abnormalities result from a primary failure of germ-cell development.

2. 'Super-male' - XYY Tall, aggressive males who may show:
 - (i) Sexual maldevelopment
 - (ii) Skeletal disorders
 - (iii) Myopia
 - (iv) Marfan's syndrome
3. 'Super-female' - XXX Females showing some loss of intelligence and infertility.
4. Turner's syndrome - XO
 - (i) Dwarfism
 - (ii) Sexual infantilism
 - (iii) Increased carrying angle of lower arms
 - (iv) Webbed neck
 - (v) Broad chest with widely spaced nipples
 - (vi) Streaked gonads in position of ovaries
 - (vii) Coarctation of the aorta

B. Gene abnormalities

- (i) Multigene deletion
- (ii) Single gene deletion
- (iii) Exon deletion
- (iv) Within exon deletion
- (v) Frame shift deletion (i.e. 3 base deletion)
- (vi) Base pair mutation
- (vii) Splice site mutation/deletion
- (viii) Promotor mutation/deletion
- (ix) Termination codon mutation/deletion
- (x) Poly A signal mutation/deletion
- (xi) Expansion of a tandem short repetitive sequence (e.g. trinucleotides)

Altered genes can be transmitted through families according to

Mendelian laws. Three main patterns of inheritance are recognised:

1. Dominant
2. Recessive
3. Intermediate

In addition the mutant gene may be sited on the X or Y chromosome in which case its inheritance is sex-linked.

Dominant inheritance

Every individual who carries a dominant abnormal gene will suffer from the disease. Nearly all affected individuals are heterozygous.

Examples include:

1. Achondroplasia
2. Brachydactyly
3. Hyperelastosis cutis (Ehlers-Danlos syndrome)
4. Marfan's syndrome
5. Familial adenomatous polyposis
6. Spherocytosis
7. Huntington's chorea

Recessive inheritance

Here the genetic abnormality is only expressed when the individual is homozygous (that is both alleles are affected). Autosomal recessive diseases are usually caused by abnormalities in genes coding for enzymes or tumour suppressor genes. The presence of abnormal enzymes, or

deficiencies of normal enzymes, gives rise to the so-called 'inborn errors of metabolism'. Recessive diseases include:

1. Cystic fibrosis
2. Wilson's disease (hepato-lenticular degeneration)
3. Retinitis pigmentosa
4. Werdnig-Hoffmann disease (progressive spinal muscular atrophy of infants)

Intermediate inheritance

In this situation the possession of a single recessive mutant gene leads to detectable abnormalities but less severe than in homozygotes.

Examples include:

1. Sickle-cell trait
2. Thalassaemia minor
3. Carriers of the phenylketonuria gene

Sex-linked inheritance

This can be either dominant or recessive

1. X chromosome
 - (i) Haemophilia
 - (ii) Christmas disease
 - (iii) Colour blindness
 - (iv) Chronic granulomatous disease
 - (v) Muscular dystrophy (Duchenne type)
 - (vi) Glucose-6-phosphate deficiency
2. Y chromosome, e.g hairy ears

Examples of inherited conditions where the type of genetic lesion is known:

1. Point mutation
 - (i) Cystic fibrosis (CFTR)
 - (ii) Glucose-6-phosphate dehydrogenase deficiency (G-6-P D)
 - (iii) Alpha-1-antitrypsin deficiency (alpha-1-antitrypsin)
 - (iv) Marfan syndrome (fibrillin)
 - (v) Beta thalassaemia (beta globin)
 - (vi) Retinitis pigmentosa (rhodopsin)
 - (vii) Familial adenomatous polyposis (apc)
2. Frame shift deletion

- (i) delta 508 deletion in cystic fibrosis (CFTR)
- (ii) Beta thalassaemia (beta globin)
- (iii) Haemophilia A and B (factor VIII and IX deficiency)
- 3. Exon or gene deletions
 - (i) Duchenne muscular dystrophy (dystrophin)
 - (ii) Lesch-Nyhan syndrome (HGPT)
 - (iii) Retinoblastoma (rb)
 - (iv) Wilms' tumour (Wt)
 - (v) beta thalassaemia (beta globin)
 - (vi) Haemophilia A and B (factor VIII and IX)
- 4. Expansion of a short tandem repetitive sequence
 - (i) Myotonic dystrophy
 - (ii) Fragile X syndrome
 - (iii) X linked spinal bulbar atrophy

C. Polygenic abnormalities

Many congenital abnormalities and major diseases such as cardiovascular disease cannot be explained on the basis of single gene inheritance. It is assumed that these defects and diseases arise by virtue of the additive effect of multiple genes.

For example genes that have been implicated in atherosclerosis:

- 1. Low density lipoprotein gene (mutated in familial hypercholesterolemia)
- 2. Apoprotein B-100 (mutated in familial defective apolipoprotein B-100)
- 3. Apoprotein C11 lipoprotein lipase (defective in lipoprotein lipase deficiency)
- 4. Apoprotein's A1, CIII and AIV (increased allele frequency in cardiovascular disease)
- 5. Fibrinogen (increased frequency of the beta allele)
- 6. Other genetic defects might be found in:
 - (i) Lipoprotein or cholesterol metabolism
 - (ii) Blood clotting and fibrinolysis
 - (iii) Macrophage function
 - (iv) Smooth muscle cell proliferation

ENVIRONMENTAL FACTORS IN CONGENITAL DISEASE

- 1. Nutritional disturbances

Experimental studies have demonstrated the importance of essential vitamins (vitamin A, riboflavin, folic acid) but clinical proof is lacking

- 2. Maternal infection
 - (i) Rubella
 - (ii) Cytomegalovirus
 - (iii) Toxoplasmosis

Malformations have also been described after influenza, measles, mumps, polio, echo and coxsackie infections. These are all rare associations and a causal relationship has not been proven.

- 3. Hormonal agents

- (i) Masculinisation of females has resulted from administration of androgens or progesterone in early pregnancy, or as a result of congenital adrenal hyperplasia
- (ii) Insulin used in treatment of maternal diabetes may lead to malformation (?)
- (iii) Hypoplasia of the adrenals results from pituitary deficiency in anencephaly

- 4. Drugs

- (i) Thalidomide (limb defects)

- (ii) Anti-metabolites

- (iii) Other commonly used drugs, e.g. salicylates, sulphonamides, and streptomycin, have had teratogenic effects in animals, but evidence in humans is lacking

- 5. Mechanical factors

Compression of the fetus is important in producing deformations, and may exaggerate deformities associated with malformations, e.g. in congenital dislocation of the hip

- 6. Irradiation

- 7. Hypoxia - may lead to cardiac malformations in children born at high altitudes

- 8. Disordered circulation in the embryo

- 9. Maternal age and birth rank

- (i) Mongolism

- (ii) Hydrocephalus

- (iii) Achondroplasia

- (iv) Anencephaly

are more frequent with increasing maternal age

- 10. Paternal age has an effect on some dominant mutations, e.g. achondroplasia

- 11. Multiple births

CONGENITAL MALFORMATIONS

Major congenital malformations are found in about 2.5% of total births, and of these neural tube defects such as spina bifida and anencephaly, and congenital heart disease account for about two-thirds.

The most important malformations are:

1. Limbs

- (i) Congenital dislocation of the hip
- (ii) Bowing of the tibia
- (iii) Talipes equinovarus (club foot)
- (iv) Congenital elevation of the shoulder (Sprengel's shoulder)
- (v) Radio-ulnar synostosis
- (vi) Syndactyly/brachydactyly

2. Alimentary tract

- (i) Cleft lip and palate
- (ii) Microstomia and macrostomia
- (iii) Atresia of the oesophagus
- (iv) Diaphragmatic hernia
- (v) Congenital pyloric stenosis
- (vi) Atresia of the intestine
- (vii) Duplication
- (viii) Hirschsprung's disease
- (ix) Imperforate anus

3. Cardiovascular system

- (i) Septal defects
 - a. Atrial
 - b. Ventricular
- (ii) Stenosis
 - a. Aortic
 - b. Pulmonary
 - c. Infundibular (RV)
- (iii) Coarctation of the aorta
- (iv) Persistent ductus arteriosus
- (v) Fallot's tetralogy
- (vi) Transposition of the great vessels

4. Central nervous system

- (i) Hydrocephalus

- (ii) Anencephalus
- (iii) Meningocele/myelocele

5. Genito-Urinary system

- (i) Kidneys
 - a. Agenesis
 - b. Hypoplasia
 - c. Cystic diseases
- (ii) Bladder
 - a. Ectopia vesicae
 - b. Persistent urachus
- (iii) Testes
 - a. Absence
 - b. Undescended
- (iv) Penis Hypospadias
- (v) Uterus
 - a. Double
 - b. Septate
 - c. Bicornuate

INBORN ERRORS OF METABOLISM

When a genetic error results in the formation of an abnormal protein, and this protein is an enzyme, the resultant biochemical defect may become manifest through the accumulation of some precursor or substrate which brings about a disease syndrome. Such diseases, usually inherited as Mendelian recessives, are termed inborn errors of metabolism. They can be grouped into four main categories involving:

- A. Errors of carbohydrate metabolism**
- B. Errors of amino-acid metabolism**
- C. Errors of lysosomal function**
- D. Errors of steroid metabolism**
- E. Errors of porphyria metabolism**

A. Errors of carbohydrate metabolism

- 1. Galactosaemia (deficiency of galactose-1-phosphate uridyl transferase)
- 2. Glycogen storage diseases include:

- (i) von Gierke's (glucose-6-phosphatase)
- (ii) Pompe's (a-1,4,6 glucosidase)
- (iii) Limit dextrinosis (amylo-1, 6-glucoSIDerase {debrancher})
- (iv) IV (amylo-1, 4-1, 6-transgiucosidase [brancher])
- (v) V McArdle's (muscle phosphorylase)
- (vi) VI (liver phosphorylase)
- (vii) VII (glycogen synthetase)

3. Fructose intolerance (fructose-1-phosphate aldolase)

B. Errors of amino-acid metabolism

1. Phenylketonuria (phenylalanine hydroxylase deficiency resulting in accumulation of phenylalanine)
2. Tyrosinosis (p-hydroxyphenylpyruvic acid oxidase deficiency resulting in accumulation of phenylalanine and tyrosine).
3. Alkaptonuria (homogentisic acid oxidase deficiency)
4. Maple syrup urine disease (branched-chain ketoacid decarboxylase deficiency resulting in accumulation of a-ketoacids)
5. Homocystinuria (cystathione synthetase)

C. Errors of lysosomal function

1. Accumulation of sphingolipids
 - (i) Tay Sachs' (hexosaminidase A)
 - (ii) Generalised gangliosidosis (b-galactosidase)
 - (iii) Krabbe's (b-galactosidase)
 - (iv) Gaucher's (b-glucoSIDerase)
 - (v) Niemann-Pick's (sphingomyelinase)
 - (vi) Metachromatic leucodystrophy (sulphatidase)
 - (vii) Anderson-Fabry's (ceramide trihexosidase)
2. Accumulation of neutral lipids
 - (i) Wolman's (acid esterase)
 - (ii) Cholesterol ester (?)
 - (iii) Cerebro-tendinous xanthomatosis
3. Accumulation of glycosaminoglycans (mucopolysaccharidoses)
 - (i) IH - Hurler (a-L-iduronidase)
 - (ii) IS - Scheie ((a-L-iduronidase)

- (iii) II - Hunter (L-iduronosulphate sulphatase)
- (iv) IIIA - Sanfilippo (heparan sulphate sulphamidase)
- (v) IIIB - Sanfilippo (a-N-acetylglucosaminidase)
- (vi) IV - Morquio (N-acetyl hexosamine)
- (vii) VI - Maroteaux-Lamy (arylsulphatase-B)

4. Accumulation of mucolipids

- (i) Mucopolipidosis types I-IV
 - (ii) Fucosidosis
 - (iii) Mannosidosis
5. Accumulation of other compounds
- (i) Refsum's disease (phytanic acid)
 - (ii) Cystinosis - Lignac-Fanconi (?)
 - (iii) Pompe's disease (lysosomal-a-glucoSIDerase)

6. Other lysosomal enzyme disorders

- (i) Hyperphosphatasia
- (ii) Hypophosphatasia
- (iii) Acid phosphatase deficiency
- (iv) Ceroid-lipofuscinosis

D. Errors of steroid metabolism

Resulting in congenital adrenal hyperplasia

The principal defects are:

1. 21-Hydroxylase deficiency
2. 11-Hydroxylase deficiency

Other enzymes may be involved, these are:

3. 17-Hydroxylase
4. 3-b-Hydroxysteroid dehydrogenase
5. Desmolase

before

after

CEMIENS FOR PAIN

IT IS A SCIENTIFIC FACT THAT A LOW LEVEL VOLTAMMETRIC PULSE CAN INHIBIT PAIN SIGNALS. THE SCIO WILL LET THE PATIENT'S BODY ELECTRIC AUTOFOCUS A HARMONIC PULSE TO MAXIMIZE THIS EFFECT. THIS IS CALLED

MICRO-CURRENT TRANSCUTANEOUS ELECTRO-NEURAL STIMULATION

AND CAN HELP YOU TO REDUCE PAIN WHILE HELPING YOU FIND THE CAUSE...



If you need more information on the SCIO and purchase details please get in touch with us

Maitreya Kft.
 tel: +3613036043
 web: www.qxsubspace.com
 e-mail: info@qxsubspace.com

17. Neoplasia

Neoplasia means 'new growth'.

CLASSIFICATION OF TUMOURS

Tumours are currently classified according to their behaviour and tissue of origin. On the basis of their behaviour they can be separated into two main groups, benign and malignant. The malignant tumours can then be separated into primary or secondary (metastatic) tumours.

The principal points of distinction between the two groups are:

	Benign	Malignant
<i>Mode of growth</i>	Expansive/pushing Circumscribed Encapsulated	Infiltrative Poorly-defined margins Non encapsulated
<i>Rate of growth</i>	Slow and may cease	Rapid
<i>Microscopic structure</i>	Well-differentiated (i.e. closely resembles tissue of origin) Cells - regular	Varying degrees of differentiation Cellular and nuclear pleomorphism (variation in size and shape) Increased mitoses
<i>Metastases</i>	Absent	Necrosis Haemorrhage Present
<i>Clinical effects</i>	Mechanical or hormonal	Mechanical, destructive, hormonal, systemic effects
<i>Outcome</i>	Rarely fatal	Usually fatal

These are general points to which there are many exceptions. Some tumours exhibit an intermediate type of behaviour and cannot be allocated to either category, e.g. giant-cell tumour of bone.

Benign tumours usually end with the suffix -oma. Malignant epithelial tumours are usually called -carcinoma and malignant tumours derived from mesoderm -sarcoma. Teratomas are derived from germ cells and tumours arising from fetal tissues or their remnants -blastomas. There are exceptions to most of these rules, for example hamartomas are not tumours, seminomas and lymphomas are both malignant, so whilst these rules are helpful, caution is required in the use of terminology.

Tissue of origin	Benign	Malignant
<i>Epithelial</i>		
squamous	Papilloma	Squamous carcinoma
glandular	Adenoma	Adenocarcinoma
transitional	Papilloma	Transitional cell carcinoma
<i>Connective tissue</i>		
Fibrous tissue	Fibroma	Fibrosarcoma
Fat	Lipoma	Liposarcoma
Bone	Osteoma	Osteosarcoma
Cartilage	Chondroma	Chondrosarcoma
Smooth muscle	Leiomyoma	Leiomyosarcoma
Striated muscle	Rhabdomyoma	Rhabdomyosarcoma
Blood vessels	Haemangioma	Angiosarcoma
Lymphoid tissue		Malignant lymphoma
Nervous system		Astrocytoma, Oligodendroglioma Ependymoma
<i>Trophoblast</i>	Hydatidiform mole	Choriocarcinoma
<i>Germ Cells</i>	Benign teratoma	Malignant teratoma
<i>Embryonic tissues</i>		
		Nephroblastoma Hepatoblastoma Medulloblastoma (brain) Retinoblastoma
	Ganglioneuroma	Neuroblastoma (sympathetic nerve)

Teratoma

A teratoma is 'a true tumour composed of multiple tissues foreign to the part in which it arises' (Willis).

Teratomas originate by neoplastic change in germ cells (which in some cases may have been arrested in their migration from the yolk sac wall).

Sites

1. Ovary (usually benign)
2. Testis (usually malignant)
3. Anterior mediastinum
4. Presacral
5. Retroperitoneal
6. Intrapericardial
7. Base of skull and nasopharynx
8. Intracranial, including pineal
9. Neck - usually within the thyroid gland

NON NEOPLASTIC CONDITIONS OFTEN CONFUSED WITH TUMOURS

Hamartoma

A hamartoma is a tumour-like malformation composed of a haphazard arrangement of mature tissues appropriate to the particular part of the body in which it is found. The distinction between a hamartoma and a benign tumour can be very difficult, and very occasionally malignant tumours develop from such malformations.

Examples

1. Respiratory system
 - (i) Pulmonary hamartoma composed principally of mature cartilage but including columnar or cuboidal epithelium and fibrous tissue
2. Intestine

e.g. Peutz-Jeghers' polyps in the small intestine associated with circumoral pigmentation
3. Multi-system involvement e.g. Tuberous sclerosis
 - (i) Skin papules - 'adenoma sebaceum,
 - (ii) Angiolipomyoma in the kidney. (These can also occur without tuberous sclerosis.)

Choristoma

A choristoma is composed of normal tissue at an abnormal site, e.g. ectopic pancreas in the small intestine or stomach or adrenal cells under the capsule of the kidney. They are not neoplasms but can rarely give rise to tumours.

COMPLICATIONS OF BENIGN TUMOURS

1. Pressure effects
 - (i) Meningioma compressing brain or spinal cord
 - (ii) Uterine leiomyoma (fibroid) compressing endometrium
2. Obstruction

- (i) Bronchial obstruction due to an adenoma
- (ii) Blockage of the mitral valve by an atrial myxoma
- (iii) CSF obstruction by an ependymoma
- 3. Ulceration and haemorrhage
 - (i) Leiomyoma of the stomach wall
 - (ii) Adenoma of the colon
- 4. Infarction, e.g. pedunculated leiomyoma
- 5. Rupture of cystic neoplasms, e.g. mucin-secreting cystadenoma of the ovary producing myxoma peritonei
- 6. Hormone production
 - (i) Islet-cell tumour of the pancreas producing insulin or glucagon
 - (ii) Pheochromocytoma
 - (iii) Adrenal cortical adenoma giving rise to
 - a. Cushing's syndrome
 - b. Conn's syndrome
 - (iv) Pituitary adenoma
 - a. Acromegaly
 - b. Cushing's syndrome
 - (v) Parathyroid adenoma
- 7. Malignant change
 - e.g. Adenomas of large intestine giving rise to adenocarcinoma, as occurs in sporadic adenomas and in familial adenomatous polyposis

COMPLICATIONS OF MALIGNANT TUMOURS

1. Invasion

- (i) Direct spread within the organ of origin, e.g. squamous carcinoma of the lung or hepatocellular carcinoma in the liver
- (ii) Spread to adjacent organ(s), e.g. adenocarcinoma of the pancreas invading duodenum, stomach or colon
- (iii) Invasion through the peritoneal or pleural surface, e.g. adenocarcinoma of the stomach or lung

2. Metastasis

- (i) Carcinomas usually spread by lymphatic invasion and involvement of lymph nodes but also by vascular spread, e.g. squamous carcinoma of the lung invading regional lymph nodes with subsequent haematogenous spread to liver, bone and brain

- (ii) Sarcomas usually spread by vascular invasion, e.g. osteosarcoma spreading to the lung
- (iii) Lymphomas usually spread by vascular and lymphatic routes initially within the immune system

3. Obstruction

- (i) Stenosis of a hollow visceral structure, e.g. colon, bile duct, ureter by primary or secondary tumour
- (ii) Obstruction of lymphatic channels, e.g. peau d'orange of the breast caused by blockage of lymphatic channels by adenocarcinoma of the breast

4. Ulceration and haemorrhage

- (i) Ulceration of a mucosal surface by a primary or secondary tumour, e.g. adenocarcinoma of the colon or squamous carcinoma of the skin or adenocarcinoma of the prostate invading into the rectum

- (ii) Haemorrhage into a tumour, e.g. renal cell adenocarcinoma

5. Infarction

6. Rupture or perforation

- (i) Cystadenocarcinoma of the ovary causing myxoma peritonei
- (ii) Teratoma of the ovary rupturing into the peritoneum
- (iii) Perforation of carcinoma of the colon

7. Hormone production

- (i) Carcinoma of the lung producing
 - a. ADH
 - b. Parathyroid hormone related peptide (PTH-rp)
 - c. ACTH
- (ii) Malignant islet cell tumours
 - a. Glucagon
 - b. Insulin
- (iii) Malignant carcinoid tumours
 - a. Serotonin
 - b. 5-Hydroxy indole acetic acid
- (iv) Renal cell adenocarcinoma
 - a. Erythropoietin
 - b. Parathyroid hormone related protein

GROWTH AND SPREAD OF TUMOURS

The most important characteristics of tumours are their capacity for:

- A. Uncoordinated growth
- B. Invasion
- C. Metastasis

A. Tumour growth

This is the result of:

- 1. The rate of entry and time spent in the cell cycle
- 2. Death of cells by:
 - (i) Apoptosis
 - (ii) Necrosis

In normal tissues the level of mitotic activity (i.e. the cell birth rate) is equal to the rate of cell loss so that the total number of cells is more or less constant. Where injury leads to cell loss in excess of the cell birth rate then atrophy or tissue damage such as ulceration will result. In neoplasia, the cell birth rate exceeds cell loss so that there is progressive accumulation of tumour cells. In some tumours, the cell birth rate although exceeding cell loss, may be lower than the prevailing level of mitosis in the surrounding tissue of origin, and this may explain the poor response of such tumours to radio- or chemotherapy. Tumour growth progresses in two ways:

- 1. Expansive growth. Purely expansive growth is a feature of many benign tumours and produces a circumscribed, encapsulated neoplasm, e.g. fibroadenoma of the breast
- 2. Infiltrative growth is usually a reflection of invasion and can be recognised around the margins of a malignant tumour.

B. Invasion

Direct spread of tumour in continuity occurs along the following:

- 1. Microscopic tissue spaces (interstitial spread)
- 2. Lymphatics - permeation as a continuous cord of tumour cells
- 3. Veins and capillary blood vessels, e.g. renal cell adenocarcinoma along the renal vein
- 4. Coelomic cavities, e.g. pleural spread of lung cancer or peritoneal spread of colonic adenocarcinoma
- 5. Cerebrospinal spaces, e.g. malignant gliomas
- 6. Epithelial cavities, e.g. uterine tumours spreading along the Fallopian tubes or into the cervix

The mechanisms underlying the invasive properties of malignant cells are not known but invasion can be blocked if protein synthesis is inhibited indicating that invasion is an active process. The following factors have been suggested as possible explanations.

- 1. Increased motility, loss of adhesiveness, and loss of substrate dependence

- (i) Loss or down-regulation of laminin or collagen receptors and cell adhesion molecule abnormalities

- (ii) Increased production of autocrine motility factors

- 2. Loss of contact and density inhibition

The failure of malignant cells to show the normal inhibition of mitosis and movement on contact may be due to:

- (i) Loss of responsiveness to inhibitory cytokines

- (ii) Defects in trans-membrane communication

- 3. Fibrin production

Fibrin is deposited around the growing margins of many tumours. The organisation of this deposit may lead to the formation of blood vessels, lymphatics and stroma, bringing nutrition to the tumour and encouraging its growth. On the other hand, the fibrin deposit may be a host reaction tending to limit the growth of the tumour. Its role in tumour spread is therefore doubtful.

- 4. Enzyme production

Although mention has been made of 'microscopic tissue spaces' and 'lines of cleavage' as routes of invasion, in reality these are filled by a relatively dense interstitial matrix composed of collagen (Types I and III), glycoproteins, and acid mucopolysaccharides (proteoglycans). This matrix forms a dense meshwork which does not normally allow the passage of cells. Furthermore, invasive cells of epithelial origin must first traverse a dense basement membrane composed of Type IV collagen.

It has now been shown that many tumours secrete collagenases capable of digesting the interstitial matrix together with a distinctive metalloproteinase which degrades basement membrane collagen. Such destruction of the extracellular matrix by proteolytic enzymes is believed to facilitate invasion. Elastase is also secreted by some tumour cells. In addition, production of plasminogen activator by tumour cells and the subsequent formation of plasmin might be important in:

- (i) Removing fibrin from around the advancing tumour margin

- (ii) Releasing pro-collagenases from the cell membrane

- (iii) Increasing vascular permeability for tumour cells

Inhibitor proteins from the surrounding tissues or the tumour cells can block metalloproteinase activity. Such factors include tissue inhibitors of metalloproteinases (TIMPS) and plasminogen activator inhibitors (PAIs). Loss of these genes may facilitate invasion.

C. Metastasis

Denotes successful growth of tumour in the body at a site distant from its primary location.

The metastatic potential of a tumour is dependent on:

- 1. The site, histological type and grade of tumour

- 2. Access of the tumour to lymphatic, vascular and other tissue/organ spaces and their drainage

Specific properties of the tumour cells as well as those of the site of the metastasis

Detached tumour cells take the following paths:

1. Lymphatics
2. Blood vessels
3. Coelomic spaces
4. Cerebrospinal spaces
5. Epithelial cavities

1. Lymphatic spread

This is most commonly associated with carcinomas, but is frequently seen with malignant melanoma and malignant teratoma of the testis.

Results of lymph node involvement:

- (i) Invasion of adjacent tissues:
 - a. veins
 - b. trachea, skin, etc.
- (ii) Compression of neighbouring structures, e.g. superior vena cava syndrome
- (iii) Further dissemination by diversion of lymph flow
- (iv) Lymphoedema of limb or scrotum

2. Blood spread

This occurs typically with sarcomas and as a later feature of spread from carcinomas. There are three continuous phases:

- (i) The invasion of blood vessels by tumour cells Mechanism
 - a. Production of degradative enzymes weakening blood vessel integrity
 - b. Imperfect endothelial lining of tumour blood vessels allowing direct access by tumour cells (especially in sarcomas)
 - c. Loss of cell-to-cell adhesiveness
- (ii) The transport of tumour cells by established vascular pathways. The presence of circulating tumour cells may be a common feature of tumours and does not inevitably lead to metastases
- (iii) The lodgement, attachment, and growth of tumour cells at the distant site. The arrest of circulating tumour cells is not a result of non-specific mechanical trapping, but probably is determined by the cell surface properties of the tumour cell such as adhesion molecules. The variation in these surface properties and their differing affinity for arrest may explain the organ specificity of metastatic tumour spread.

Examples of organ specificity

Carcinoma of the breast, thyroid, kidney, lung and prostate frequently metastasise to bone

- b. Carcinoma of the bronchus often involves the liver and adrenals

- c. Carcinoma of the colon and rectum spread to the liver
- d. Seminoma (testis) spreads to the lung
- e. Sarcomas spread principally to the lung but also to liver and brain

3. Coelomic spaces Examples

- (i) Spread from a gastric or intestinal primary to the ovaries (Krukenberg tumours)
- (ii) Pleural spread of lung and breast cancer
- (iii) Peritoneal spread of ovarian carcinoma

4. Cerebrospinal spaces

Primary tumours of the CNS may spread via the subarachnoid space or the ventricular system and give rise to seedlings distant from their origin.

5. Epithelial cavities

This mode of spread is rare. One example is implantation of desquamated tumour cells from an intestinal carcinoma into anastomosis sites during surgical removal.

PATHOLOGICAL ASSESSMENT OF NEOPLASIA

Three features of a tumour must be determined

The tissue of origin and type of tumour

- (ii) How far in its natural history has it progressed - the stage of the tumour
- (iii) How aggressive is the tumour - the grade of the tumour

Origin and type of tumour

The mode of spread and its extent are strongly influenced by the site and tissue of origin and the nature of the tumour. Furthermore the form of treatment will often be dictated by these factors.

Stage

The stage of a tumour is determined from the degree of invasion and the presence and extent of metastasis.

A frequently encountered example is in colorectal cancer Dukes' staging. This is a widely used modified scheme:

- (i) Stage A: invasion through the muscularis mucosae has occurred but the tumour has not penetrated through the muscularis propria. Survival 90%
- (ii) Stage B: The muscularis propria is breached but no metastases are detected. Survival 60%
- (iii) Stage C1: Peri-tumoural lymph node involvement is present. Survival 40%
- (iv) Stage C2: The highest lymph node resected, i.e. the node at the vascular tie, is involved. Survival 20%

Stage D: Distant metastases to the liver or unresectable local disease. Survival 0-5%.

Staging systems differ depending on the type, site and clinical behaviour of the tumour.

Grade

Two tumours at the same stage may have very different outcomes as one may behave more aggressively than the other. The aggressiveness of the tumour is often reflected by the 'grade' of malignancy. The grade is usually based on the degree of similarity of the tumour to the fully mature 'differentiated' state of the tissue of origin.

- (i) Well differentiated/low grade - closely resembles tissue of origin
- (ii) Moderately differentiated/intermediate grade
- (iii) Poorly differentiated/high grade - difficult to recognise the tissue of origin

PREMALIGNANCY

It is frequently possible to recognise precursor lesions of malignant tumours. Often these are benign tumours such as colorectal adenomas which precede colorectal adenocarcinomas. In other situations a benign tumour is not present but morphological abnormalities may still be identified. These abnormalities are called dysplasia.

Dysplasia

A pre-malignant disturbance of cell proliferation and maturation. It is generally assumed that once initiated dysplasia will inevitably progress (through increasing grades of severity) to an invasive malignant tumour. However, it must be said that evidence is accumulating that dysplasia can remain static or regress.

The most severe end of the dysplasia spectrum can be synonymous with intra-epithelial carcinoma or carcinoma-in-situ. Dysplasia is recognised by:

1. Pleomorphism of cells (excessive variation in shape and size)
2. Hyperchromatic nuclei and increased mitotic activity
3. Loss of polarity (orientation) of cells
4. Disordered maturation
5. Absence of invasion

Dysplasia and carcinoma-in-situ are found in:

A. Squamous epithelia

1. Cervix uteri - 'Cervical Intra-epithelial Neoplasia (CIN)'
 2. Vagina and vulva (VIN)
 3. Oro-pharynx and oesophagus
 4. Larynx
 5. Skin
- (i) Paget's disease of the skin

This is usually (but not invariably) associated with an underlying but separate adenocarcinoma and is found in the nipple, axilla, anus, and vulva

- (ii) Bowen's disease (intra-epidermal carcinoma)
6. Bronchus in areas of squamous metaplasia
- #### B. Transitional epithelium of the urinary system, especially in the bladder
- #### C. Columnar secretory epithelia
1. Gastric mucosa in
 - (i) Chronic gastritis
 - (ii) Margins of a chronic peptic ulcer (uncommon)
 - (iii) Menetrier's disease (rare)
 2. Large intestinal mucosa
 - (i) Ulcerative colitis
 - (ii) Crohn's disease
 3. Small intestinal mucosa (rare)
 - (i) Crohn's disease
 - (ii) Coeliac disease
 4. Ductal epithelia
 - (i) Breast - atypical hyperplasia and intra-duct carcinoma (also lobular carcinoma-in-situ)
 - (ii) Bile ducts
 - (iii) Pancreatic duct
 5. Endometrium

D. The bone marrow - Myelodysplasia

The importance of the premalignant phase is that removal or treatment of the lesion may prevent it becoming invasive or spreading. Screening for neoplasia is usually based on identifying the premalignant or early malignant stages of the disease.

AETIOLOGY OF TUMOURS

Tumours are induced by a variety of mechanisms including:

1. Chemicals
2. Physical agents
3. Viruses
4. Genetic lesions

Our knowledge is far from complete but these general principles apply:

1. Agents capable of causing tumours usually mediate their effects through damage to DNA
2. Different types of genes are affected

3. A range of genetic lesions occur varying from a single base pair mutation to loss of the entire gene or chromosome. More than one type of lesion may be seen in the same gene on different alleles
4. The number and type of genetic lesions required to induce a tumour depends on the maturity and type of tissue
5. The type and frequency of events differs from tissue to tissue and may be highly specific to one tumour or common to a wide range of tumours
6. The sequence of genetic events may vary in tumours of the same type

A. Chemical

Of largely historical interest, early examples of chemical carcinogenesis are:

1. Carcinomas of the scrotum in chimney sweeps
2. Cancer of the hands and arms in shale-oil workers
3. Cancer of the skin and lung after long-term exposure to arsenic (still seen occasionally)

Present day examples are:

4. Carcinoma of the lung
 - (i) Tobacco smoke
 - (ii) Asbestos
 - (iii) Chromate smelting
5. Carcinoma of the bladder
 - (i) Aniline dye production
 - (ii) Rubber manufacture
6. Carcinoma of the nasal sinuses in wood-workers
7. Carcinoma of the skin in tar-workers
8. Haemangiosarcoma of the liver in vinyl chloride workers

Experimental carcinogenesis

Most, if not all, chemical carcinogens undergo some metabolic conversion to form either intermediate compounds called Proximate carcinogens or active alkylating or arylating products which bind to DNA, and to a lesser extent, RNA and protein. These active products are termed the ultimate carcinogens and can modify the genome of the cell by:

1. Direct action on DNA
2. Modification of TRNA followed by the production of mutant DNA by the reverse transcriptase mechanism

These modifications may have the following effects on the cell:

1. Cell death
2. DNA damage followed by successful repair

3. DNA damage with faulty repair conferring neoplastic potential
4. Stable mutation and transmission of DNA damage to its progeny, possibly leading to neoplasia

Chemical carcinogens

1. Locally-acting chemical carcinogens, e.g. polycyclic aromatic hydrocarbons such as 3:4 benzpyrene, 3:methylcholanthrene These are 'strong' carcinogens characterised by:
 - (i) Action at the site of administration
 - (ii) Most tissues will respond
 - (iii) High tumour yield
2. Remotely-acting carcinogens
 - (i) Procarcinogens are either activated through several steps 'proximate carcinogens' to the ultimate carcinogen or the ultimate carcinogen may be formed in one step e.g. N-methyl-4-aminoazobenzene (MAB) produces liver tumours after oral administration because the liver is the site of its metabolic conversion to the carcinogenic N-hydroxy derivative.
 - (ii) Detoxification and excretion of a procarcinogen can also lead to cancer if subsequent modification of the detoxified product occurs, e.g. the excretion product of b-naphthylamine is activated in the urine giving rise to bladder tumours

Examples of chemical carcinogenesis

1. Naturally occurring
 - (i) Aflatoxin, a product of the fungus *Aspergillus flavus*, is a frequent contaminant in foodstuffs in the tropics. It produces liver and kidney tumours in animals. Known to induce point mutations in the p53 gene
 - (ii) Cycad nuts. The active principal cycasin induces tumours of kidney, liver and colon in animals
 - (iii) Senecio alkaloids (ragwort) - ? liver cancer
 - (iv) Nitrosamines in certain smoked foods - ? gastric cancer
2. Polycyclic aromatic hydrocarbons
 - (i) Pitch, coal-tar, creosote and oil products (skin)
 - (ii) Cigarette smoking (lung)
3. Aromatic amines
 - (i) b-naphthylamine urothelial cancers
 - (ii) benzidine
 - (iii) auramine and magenta
 - (iv) aminoazo dyes - liver tumours
 - (v) 2-acetylaminofluorene - liver and bladder tumours

4. Vinyl chloride monomer - haemangiosarcoma of liver

Biology of carcinogenesis

1. The effects of carcinogens are dose-dependent, additive, and irreversible
2. Carcinogenesis occurs after a variable latent period during which a series of modifications occurs converting a normal cell, through successive generations, into a cancer cell. Such modifications are accelerated and enhanced by cell proliferation, and chemicals promoting the change from a modified to malignant cell may not be carcinogenic themselves, e.g. Croton oil

Thus the initial lesions of DNA, although modifying the cell, do not necessarily lead to neoplasia. The modified cell has to come under the influence of promoters which selectively stimulate the cell to divide at the expense of surrounding cells. In this way, the initiated cell population is greatly amplified. Even at this stage the enlarged population of initiated cells may undergo regression or maturation to normal-appearing tissue. The alternative, however, is for persistence and eventual transformation to a self-generating population of cells no longer dependent upon exogenous stimuli and these constitute cancer cells. In embryonal tumours the number of events required may be as little as two whereas in adult tumours multiple episodes of damage are required, in some instances as many as seven have been suggested. This probably explains why tumours predominantly affect the elderly. Once the neoplasm has been formed it then becomes invasive and subsequently undergoes progression. Tumour cells with different biochemical characteristics evolve. Those most suited to the local environment survive and proliferate whereas those not so well adapted decline in number or die. Metastatic variants and cells unresponsive to therapeutic modalities may develop.

B. Physical

1. Solar radiation. Ultraviolet light causes DNA damage by dimerising pyrimidines
 - (i) Squamous and basal cell carcinomas of the skin
 - (ii) Melanomas
2. X-irradiation
 - (i) Skin cancer
 - (ii) Leukaemia
3. Radio-active substances - alpha and beta particles, protons and neutrons cause damage by removing electrons from atoms with which they interact forming highly charged radicals which bind to and damage DNA
 - (i) Lung cancer due to radon (Schneeberg miners)
 - (ii) Osteogenic sarcoma following ingestion of radium, strontium, mesothorium (luminous paint)
 - (iii) Liver tumours following 'thorotrast' (thorium dioxide) administration for radiological purposes
4. Heat - this is dubious but it could act by promotion of the effects of a carcinogen possibly present in the fuel, e.g. in Changri cancer of the abdominal wall (charcoal braziers tied around the

abdomen in Kashmir)

C. Viruses

Different types of virus induce tumours through different mechanisms.

Retroviruses

These are RNA viruses with a simple RNA genome. Two different types exist, the rapidly transforming retroviruses (RTRV) and the slowly transforming retroviruses (STRV). The former can induce tumours in animals within weeks of infection whereas the STRV take much longer.

Mechanism of action

A RTRV may either infect a cell itself or more usually in association with an STRV. RTRVs have an extra gene over the STRVs called an oncogene. This gene varies between different viruses but it has the same effect in that if it is removed or inactivated the RTRV can no longer rapidly induce tumours. If this gene is isolated and transfected into cells in vitro then the cells will transform and behave as tumour cells. This gene is therefore capable of causing tumours - an oncogene.

It was subsequently discovered that all organisms have a range of these genes and that they are highly conserved at all levels of the animal kingdom. Study of the structure of RTRV oncogenes and the equivalent genes in animals showed that the animal genes had introns (non coding regions) inserted between exons (coding regions) whereas the viral genes did not. It is now known that RTRV oncogenes were obtained by 'hijacking' an animal cellular oncogene mRNA and incorporating it into their genome. This gave the RTRV an advantage over the STRVs as they could control the cell regulatory processes more easily. Thus retroviral induced transformation can come about by two mechanisms:

1. The introduction of 'new' viral oncogenes into cells which following integration bring about the synthesis of virally coded proteins controlling cell growth and division
2. The activation of pre-existing genetic sequences (protooncogenes) and inappropriate production of host proteins controlling cell growth and division. Such activation can also be produced by carcinogens and irradiation.

Possible RNA virus candidates as human tumour viruses:

1. Human T-cell leukaemia/lymphoma virus (HTLV-1)
2. HTLV-2 and HTLV-5
3. Human immunodeficiency virus and Kaposi's sarcoma

DNA viruses

DNA viruses act either by inserting close to a proto-oncogene and causing inappropriate expression (? hepatitis B), or by producing viral proteins, e.g. E6 (human papilloma virus) and E1b (adenovirus) which inactivate the product of p53, and E7 (human papilloma virus) and E1a (adenovirus) which bind to the retinoblastoma gene product.

DNA viruses implicated in human neoplasia

1. Human papilloma virus (HPV)
 - (i) HPV 1 - plantar warts

- (ii) HPV 5 - squamous carcinoma in epidermodysplasia verruciformis (v. rare)
- (iii) HPV 6 and HPV 11 - condyloma acuminatum and genital verrucous carcinoma
- (iv) HPV 16,18, 31, 33, 35, 51 - cancer of the cervix
- 2. Epstein Barr virus in
 - (i) Burkitt's lymphoma
 - (ii) Nasopharyngeal carcinoma
 - (iii) Hodgkin's disease
- 3. Hepatitis B virus - hepatocellular carcinoma

Ways of establishing human viral oncogenesis:

1. Isolation of virus from the tumour
2. Isolation of virus-specific products from the tumour
3. Demonstration of cell transformation by virus in culture
4. Cells transformed by the virus in tissue culture are able to produce tumours in animals
5. Infection with the virus precedes the development of cancer
6. Sero-epidemiological studies
7. Vaccination against the virus lowers the incidence of cancer

D. Genetic basis of neoplasia

A variety of types of gene have been implicated in neoplasia:

1. Proto-oncogenes activated to oncogenes
2. Tumour suppressor genes: inactivated or deleted
3. Metastasis genes: decreased expression or deletion
4. Senescence genes: deleted

Proto-oncogenes fall into four groups each class being activated by a variety of methods

Alterations in oncogenes

1. Growth factors (GF)
 - (i) Increased production of growth factor(s)
 - (ii) Inappropriate production of growth factor(s)
 - (iii) Loss of production of inhibitory growth factor(s), e.g. TGF- β
2. Growth factor receptors (GF-r)
 - (i) Increased numbers of receptors caused by overexpression or by amplification of the GF-r gene, e.g. erb-B, erb-B-2 in breast cancer
 - (ii) Abnormal receptors which do not require GF stimulation, e.g. erb-B in gliomas
3. Signal transduction

- (i) Point mutations in GTPase binding proteins increasing the level of signal transmission, e.g. ras family in colorectal cancer, gsp in pituitary adenoma
- (ii) Over-expression of GTPase binding proteins or tyrosine kinases increasing the level of signal transduction, e.g. ras, src, yes
- (iii) Translocation of a tyrosine kinase to form a new protein product with increased activity, e.g. abl-bcr in chronic myeloid leukaemia
- 4. Nuclear factors
 - (i) Gene amplification of cell cycle control proteins, e.g. nmyc in neuroblastoma
 - (ii) Translocation of inactive gene to an area under the influence of an active promoter, e.g. myc in Burkitt's lymphoma
 - (iii) Point mutations increasing the stability of a protein, e.g. p53 in a wide range of tumours
 - (iv) Increased expression of a range of nuclear factors, e.g. myb, fos

Tumour suppressor genes

In vitro evidence

This class of genes was discovered from fusion experiments between normal and tumour cells. The resultant hybridoma cells showed a non malignant phenotype. These experiments proved that malignancy could be suppressed given the influence of the genes from a normal cell.

Dominantly inherited cancer

Tumour suppressor genes have frequently been identified by the analysis of familial cancers. Retinoblastoma - a tumour of the retinoblasts of the retina - can occur sporadically or within a family as a dominantly inherited disease where it is associated with deletions of chromosome 13q14. By restriction fragment length polymorphism analysis, gene probing and DNA sequencing the retinoblastoma gene *rb* was identified. The retinoblastoma gene product is a nuclear transcription factor. The development of inherited and sporadic retinoblastoma is shown on page 203.

The function of the retinoblastoma gene as a tumour suppressor gene has been confirmed by the reintroduction of *rb* into retinoblastoma cells in vitro. The cells reverted towards a normal phenotype.

Other tumour suppressor genes:

- (i) Wilms'tumour genes WT-1 and WT-2 on chromosome 11. Two loci have been identified.
- (ii) Familial adenomatous polyposis (FAP). The APC gene on chromosome 5q21 is mutated or deleted in FAP. An adjacent gene called the MCC gene (mutated in colorectal cancer) also plays a role in sporadic colorectal cancer.
- (iii) Neurofibromatosis. NF-1 on chromosome 17q11. NF-2 is implicated in schwannomas and resides on chromosome 22q.
- (iv) Multiple endocrine neoplasia-1 (MEN-1). The MEN-1 gene is located at 11q12 and MEN-2A between 10p12-q11. Other abnormalities may be seen on 1p and 22q.
- (v) p53. This gene on 17p is one of the most frequent targets for DNA damage yet known. If it sustains a point mutation in one of several areas it stabilises the protein extending its usually very

short half life. This activating point mutation makes p53 act as an activated oncogene. Mutant p53 binds with wild type p53 to create an inactive complex. Thus p53 acts by a dominant negative effect. Loss of the remaining normal (wild type) allele causes complete loss of the tumour suppressor function of p53 leaving the abnormal p53 protein complexes only. p53 can also be bound by viral proteins such as adenovirus E1b and human papilloma virus protein E6. These proteins neutralise its tumour suppressor function

(vi) 3p. Consistent loss of heterozygosity of 3p in small cell lung cancers and other tumours.

Metastasis genes

Fusion of metastatic cells with non-metastatic cells can lead to a temporary cessation of the metastatic phenotype. nm23 is a putative metastasis gene that is involved in colorectal and breast cancer. It is down-regulated or deleted in cancers which have metastasised. The gene has homology to the family of nucleoside diphosphate kinases which are involved in microtubule function and interact with G proteins.

Senescence genes

A group of genes on a number of different chromosomes are involved in genetically programming senescence. Cell fusion experiments between a normal cell and an immortal cell indicate that these genes can 'remember' the Hayflick number of the normal cell. Deletion of these genes allows the cell to become immortal but not transformed.

Molecular pathology of colorectal cancer

The best characterised tumour system with regard to molecular events is the adenoma-carcinoma sequence of the colorectal cancer. The earliest lesion occurs in the APC or MCC genes on chromosome 5. Initially this is thought to be a point mutation with possible subsequent loss of the remaining normal allele. This leads to a hyperplastic mucosa. A variety of genes subsequently become hypomethylated and early adenomas are formed. Kirsten ras mutations at codon 12, 13 or 61 may then occur. At the adenoma-carcinoma interface point mutations of p53 with subsequent loss of the wild type allele occurs. Deletions of the deleted in colorectal cancer gene (DCC), a cell adhesion gene, may then be seen. Abnormalities of nm23, rb and chromosomes 1, 3, 12 and 22 may also occur.

The complete dissection of these multiple events requires further research but it is a good example of the multistep pathway of neoplasia.

BIOLOGY OF NEOPLASTIC CELLS

Morphological changes

Morphological observations on cancer cells have revealed a number of differences from normal cells but these are non-specific:

1. Increase in nuclear and cytoplasmic volume with an increase in the nuclear-cytoplasmic ratio
2. Irregular nuclear shape and multiple nucleoli
3. Numerous misshapen protrusions from the cell surface
4. Disorganised cytoskeleton
5. Simplification of cytoplasmic organelles

6. Formation of tumour giant cells

7. Abnormal mitotic figures

Biochemical alterations

1. Composition of the cell surface

(i) Loss of glycoprotein molecules

(ii) Deletion of saccharide residues from glycolipids

(iii) Loss of fibronectin

2. Cell surface properties

(i) Enhanced mobility of receptor resulting from loss of cytoskeletal attachment to integral glycoproteins

(ii) Increase in number of cell surface receptors, abnormal structure of receptor or loss of receptors

(iii) Expression of fetal, viral, or neo-antigens

(iv) Shedding of antigens (and other glycoproteins)

(v) Increase in the net negative charge on the plasma membrane

3. Changes in nuclear DNA

(i) Hypomethylation

(ii) Increased DNA content expressed as DNA aneuploidy

4. Enzyme production and release

(i) Increased protease activity (including collagenases and plasminogen activator)

(ii) Increased release of alkaline phosphatase and glycosyl transferase

5. Transport

Increased uptake of sugars and amino acids

6. Cyclic nucleotides Increased cyclic GMP

Behavioural characteristics in vitro

1. Loss of senescence

Whilst normal somatic cells can only undergo a finite number of divisions (Hayflick number), neoplastic cells will proliferate ad infinitum under ideal culture conditions

2. Loss of contact inhibition

When normal cells which are proliferating and spreading come into contact, a 'cut-out' mechanism operates and mitosis and movement ceases. Malignant cells show a loss of such 'contact inhibition' and proliferation persists

3. Increased motility

Compared with normal cells, it is claimed that neoplastic cells migrate more rapidly, probably as a

consequence of altered cytoskeletal function

4. Decreased cell-to-cell adhesion

The presence of specific topographic patterns of macromolecules at the cell surface may serve as a mechanism for cellular recognition and adhesion. Disturbances in the arrangement of macromolecules on tumour cells may explain the breakdown in cell-to-cell signals that underlie such phenomena as contact inhibition and mutual adhesiveness

5. Loss of substrate dependency

Most normal cells require attachment to a suitable substrate before proliferation can occur; this attachment being mediated by binding proteins such as fibronectin and laminin . Neoplastic cells show a greatly diminished dependence on substrate attachment for proliferation.

HORMONAL FACTORS IN NEOPLASIA

Whilst it is well known that hormones can greatly modify the production and growth of tumours, their role in the causation of tumours is less clear. It is probable that hormones act as promoters of malignant change already initiated by some other factor such as a virus or chemicals.

Examples

1. Oestrogens

(i) In mice oestrogens promote the development of mammary cancer which has been initiated by the Bittner virus

(ii) Administration of artificial oestrogens to trans-sexual men has resulted in a few cases of mammary carcinoma

(iii) Breast carcinoma in women may undergo regression after adrenalectomy and oophorectomy

(iv) Hyperoestrogenism, for example due to a granulosa cell tumour of the ovary, may give rise to endometrial carcinoma

(v) Adenocarcinoma of the vagina in the daughters of women given stilboestrol in pregnancy

(vi) Oral contraceptives giving rise to liver cell adenomas and a few cases of hepatocellular carcinoma

2. Trophic hormones

(i) Gonadotrophins will bring about proliferation and in some cases malignant change in the ovaries of experimental animals which have been transplanted into the spleen. In this site the oestrogens released by the ovary are inactivated by the liver and there is reduced feed-back to the pituitary which responds by excessive production of gonadotrophins (feed-back deletion)

(ii) Excess TSH and ACTH levels may bring about tumour formation in the corresponding target organs in experimental animals

(iii) A possible increase in tumours in patients with growth hormone overproduction (acromegaly)



SCIO

CE
measures treats

Volts and Oscillations (EMG, EEG)

Amps and Oscillations (ECG)

Resistance (GSR)

Hydration

Oxidation (Redox potential)

Ph acid vs alkalinity

Reactivity evoked potential to voltammetric fields of substances (TVEP) over 228,000 measures a second of these energetic factors

Brain wave and emotions with (MCES)

Pain with (MENS) (TENS)

Trauma or wounds (EWH)

Electro Weakness Ph, Redox disorder (VARHOPE Correction)

Trickle charge the body electric

If you need more information on the SCIO and purchase details please get in touch with us

Maitreya Kft.

tel: +3613036043

web: www.qxsubspace.com

e-mail: info@qxsubspace.com



All designed to detect + reduce Electro-stress and Balanace the Body Electric Automatically

IMMUNOLOGICAL FACTORS IN NEOPLASIA

The immunological theories of oncogenesis depend upon some breakdown of the normal capacity to recognise neoplastic cells as 'foreign' and to react against them. This ability to recognise mutant cells is termed 'immunological surveillance'. The existence of immunological surveillance presumes that there are antigenic differences between normal and neoplastic cells. Evidence for the development of tumour antigens and immune reactions to them has been drawn from animals and humans.

Evidence in animals

1. Syngeneic animals can reject transplanted tumour if previously immunised against it (e.g. with irradiated tumour cells)
2. The presence of circulating antibodies cytotoxic to tumour cells in vitro has been demonstrated in viral-induced animal leukaemias
3. Immune lymphocytes produced in one animal will cause regression of chemically-induced tumours when injected into syngeneic animals
4. After a primary solid tumour has been removed from an animal, it is more difficult to re-establish the tumour and a large inoculum must be given
5. Animals rendered immunodeficient by neonatal thymectomy or made tolerant to tumour antigens are more susceptible to oncogenesis
6. Vaccination against an animal oncogenic virus (turkey herpes virus) can prevent tumour development in chickens

Evidence in man

1. Circulating antibodies to tumour antigens have been demonstrated in malignant melanoma, neuroblastoma, Burkitt's lymphoma and nasopharyngeal carcinoma (which cross-react with EB virus), osteogenic sarcoma, etc.
2. Cell-mediated immunity can be demonstrated to tumour specific antigens by macrophage migration inhibition, etc.
3. Histological evidence; With certain tumours, those that have a prominent lymphocytic stromal infiltrate ('host reaction') have a better prognosis
4. Correlation between prognosis and the number and reactivity of circulating lymphocytes
5. Immunodeficiency or immunosuppression is associated with an increased incidence of non-Hodgkin lymphomas, squamous and basal carcinomas and melanomas
6. Tumour cells which have been inadvertently transplanted into the recipients of renal homografts taken from cancer patients have grown successfully because of immunosuppression of the host
7. Spontaneous full or partial regression of tumours, e.g. melanomas
8. Dramatic response after small doses of chemotherapy, e.g. in Burkitt's lymphoma and choriocarcinoma
9. Removal of a primary tumour may be followed by regression of secondaries

10. Long-standing relapses after presumed 'dormancy' of cancer cells. In some cases relapse has followed an alteration in immune status resulting from immunosuppressive treatment, irradiation, etc.

Development of tumour antigens

Alteration of the genome by an oncogenic agent may lead to the formation of new antigens at the cell surface. These might not respond to cytokines and contact stimuli appropriately and react by excessive proliferation or tissue invasion.

1. Virus alterations result in a new surface antigen which is characteristic of the infecting virus and common to all tumours produced by that virus
2. Chemical carcinogens also induce new surface antigens but these differ from tumour to tumour (idiotypic)
3. Some tumours develop fetal antigens not normally expressed in adult tissues, e.g. CEA, (a-fetoprotein)

Effector mechanisms in tumour-cell killing

1. Sensitised killer T-lymphocytes
2. Natural killer lymphocytes
3. Antibody-dependent cell-mediated cytotoxicity
4. Complement-mediated cytolysis
5. Macrophage killing following:
 - (i) Antibody attachment (Fc)
 - (ii) Cytokine activation

Failure of the immune response

Immune surveillance may fail if the

1. Tumour is non-antigenic
2. Immune system is inefficient because of
 - (i) Increasing age
 - (ii) Human immunodeficiency virus infection
 - (iii) Immune suppression in transplant recipients
3. Cancer cells evade the immune mechanisms
 - (i) Tolerance
 - a. Oncogenic virus transmitted vertically or present from birth, e.g. hepatitis B
 - b. Activation of T-suppressor cells
 - c. High dose suppression by antigens shed from tumour cells
 - (ii) Blocking of cytotoxic effects on tumour cells by

- a. Formation of soluble Ag/Ab complexes (shedding of tumour antigens leads to production of immune complexes in Ag excess)
- b. Shedding of cell-bound Ag/Ab complexes
- c. Increased endocytosis of cell-bound Ag/Ab complexes
- (iii) Escape from complement-mediated cell lysis
 - a. Localised concentration of surface antigens (antigen 'capping') leads to aggregation of Ag/Ab complexes so that steric hindrance prevents complement binding
 - b. Changes in the lateral mobility of surface antigens may hinder the critical alignment of Ag/Ab complexes necessary for complement activation

Other factors in tumour formation

Tumour formation is also influenced by:

1. Age

Carcinoma of the bronchus, colorectum, stomach and pancreas all increase with age whereas carcinoma of the breast and cervix occur earlier with only a small increase with age. Hodgkin's disease and osteogenic sarcoma occur with a bimodal distribution, in young adults and the elderly. Germ cell tumours tend to occur in 30's and 40's and blastomas in children.

2. Sex

Variability in incidence between sexes for most major types of cancer

3. Genetic background

Family history of tumours strongly affects predisposition to specific types of tumour

4. Race

5. Geographical location

6. Hormonal status

7. Immune function

8. Diet

9. Chronic inflammation

COMMONEST MALIGNANT TUMOURS IN ADULTS

1. Carcinoma of the bronchus (squamous, small cell and adenocarcinoma)
2. Squamous and basal cell carcinomas of the skin
3. Adenocarcinoma of the colon and rectum
4. Adenocarcinoma of the breast
5. Adenocarcinoma of the stomach
6. Adenocarcinoma of the prostate
7. Transitional cell carcinoma of the bladder

8. Lymphoma and leukaemia
9. Carcinoma of the oesophagus
10. Adenocarcinoma of the ovary

COMMONEST MALIGNANT TUMOURS OF CHILDHOOD

1. Leukaemia (32% of total) of which about 80% are acute lymphocytic leukaemia
2. Lymphoma (10%)
 - (i) Non-Hodgkin's lymphoma including Burkitt's lymphoma (5%)
 - (ii) Hodgkin's disease (5%)
3. Brain tumours (25%) including
 - (i) Medulloblastoma (cerebellum) (5%)
 - (ii) Astrocytoma, frequently sub-tentorial (9%)
 - (iii) Ependymoma (5%)
4. Neuroblastoma (6%)
From sympathetic ganglia and adrenal medulla Some mature into ganglioneuroma
5. Nephroblastoma (Wilm's tumour) (5%)
Composed of tubules and immature glomeruli in a mesenchymal stroma which may contain striated muscle, fat, cartilage and bone
6. Retinoblastoma (3%)
7. Hepatoblastoma (1%)
8. Germ cell tumours (yolk sac tumour, teratoma) (4%)
9. Rhabdomyosarcoma and other soft tissue sarcomas (5%)
10. Osteogenic sarcoma (3%)
Most commonly at the lower end of the femur, then the upper part of the tibia
11. Ewing's tumour (2%)

NON-METASTATIC EFFECTS OF TUMOURS

A. Skin markers of malignancy

1. Acanthosis nigricans
almost always associated with carcinoma - 75%
adenocarcinoma
Dermatomyositis
about 15% of cases associated with malignancy
Necrolytic migratory erythema with glucagonoma

4. Exfoliative dermatitis
with lymphomas and leukaemias
 5. Erythema gyratum repens
with carcinoma of the bronchus
 6. Pigmentation
in carcinomatosis
 7. Pruritus
in lymphomas and some carcinomas
 8. Herpes zoster
in Hodgkin's lymphomas
 9. Bullous pemphigoid (?)
 10. Acquired ichthyosis in lymphomas
 11. Fixed LE-like eruptions
 12. Hypertrichosis
- B. Neuromuscular effects**
1. Myopathy
with various carcinomas and lymphomas
 2. Myasthenic syndrome
with intrathoracic tumours usually oat-cell carcinoma of bronchus and thymoma
 3. Mixed neuropathy (sensory and motor)
with many types of carcinoma, e.g. bronchus, stomach, breast, together with lymphomas and myeloma
 4. Sensory neuropathy
a rare complication of carcinoma of the bronchus
 5. Autonomic neuropathy
 6. Dementia or psychosis
 7. Cerebellar degeneration
with carcinoma of bronchus, breast, ovary and lymphomas
 8. Brain stem degeneration
may accompany some other neuromuscular lesion
 9. Progressive multifocal leucoencephalopathy caused by papova virus
very rare; association with lymphoma

- C. Haematological effects**
1. Thrombotic disorders
 - (i) Venous thrombosis
especially carcinoma of the pancreas and mucinproducing carcinomas
 - (ii) Non-bacterial thrombotic endocarditis
 - (iii) Disseminated intravascular coagulation - prostate, bronchus, stomach, pancreas
 - (iv) Microangiopathic haemolytic anaemia, usually advanced carcinoma of stomach, pancreas, colon, lung and breast
 2. Miscellaneous
 - (i) Normocytic normochromic anaemia
 - (ii) Autoimmune haemolytic anaemia Hodgkin's disease, lymphomas, thymoma
 - (iii) Sideroblastic anaemia
 - (iv) Thrombocytopenia
 - (v) Red cell aplasia associated with thymoma
 - (vi) Polycythaemia with renal carcinoma, etc.
- D. Hormonal effects - due to inappropriate production by tumour cells**
1. Cushing's syndrome (ACTH production)
associated with oat-cell carcinoma of the bronchus, thymoma, carcinoid tumours, medullary carcinoma of the thyroid
 2. Hyponatraemia (ADH-like substance) oat-cell carcinoma
 3. Hypoglycaemia (insulin-like substance)
mesothelioma, liver cell carcinoma, adrenal cortical carcinoma
 4. Hypercalcaemia (parathyroid hormone related peptide) carcinoma of the bronchus and cervix, renal carcinoma, lymphomas, small cell carcinoma of the ovary and breast carcinoma
 5. Polycythaemia (erythropoietin production)
renal adenocarcinoma and occasional cases of uterine leiomyoma, hepatocellular carcinoma, cerebellar haemangioblastoma, nephroblastoma
 6. Carcinoid syndrome (5-H-T)
oat-cell carcinoma, medullary carcinoma of the thyroid
 7. Gynaecomastia (HCG or human placental lactogen)
with anaplastic or squamous carcinomas of bronchus, testicular tumours, hepatocellular carcinoma
 8. Hypertension (excess renin production) from nephroblastoma
 9. Hyperthyroidism (TSH-like substance)

- (i) Hydatidiform mole and choriocarcinoma
 - (ii) Malignant teratoma trophoblastic of testis
10. Pigmentation (melanocyte stimulating hormone - MSH) oat-cell carcinoma of bronchus

TUMOUR MARKERS

A tumour marker is a substance, usually detected in the serum, whose concentration can be related to the presence of a tumour. The substance need not necessarily be tumour-specific but can be used as a marker because it is secreted in much greater quantities by tumour cells.

Clinically useful serum markers include:

1. Human chorionic gonadotrophin - HCG
2. Alpha foeto-protein - AFP
3. Carcino-embryonic antigen - CEA
4. Pregnancy associated beta1 globulin - PAb1 G
5. Placental alkaline phosphatase
6. Prostatic acid phosphatase and prostate specific antigen
7. Paraproteins (monoclonal immunoglobulins)

These markers are of value in the diagnosis and/or follow-up of the following tumours:

- | | |
|-----------------------|---|
| 1. Choriocarcinoma | HCG |
| 2. 'Yolk sac tumour | AFP |
| 3. Malignant teratoma | HCG, AFP, PAb1 G |
| 4. Dysgerminoma | HCG, placental alkaline phosphatase |
| 5. Prostatic cancer | prostatic acid phosphatase, prostate specific antigen |
| 6. Colorectal cancer | CEA (in follow-up) |
| 7. Myeloma | Paraproteins |
| 8. Hepatoma | AFP |

CANCER THERAPY

Treatment of cancer is by surgery, irradiation, chemotherapy or by manipulation of hormonal or immune function.

Chemotherapy

Factors affecting chemotherapy:

1. Efficiency of absorption/delivery
2. Drug concentration
3. Duration of exposure

4. Rate of metabolic breakdown
5. Rate of excretion
6. Development of resistance to agent

Major groups of chemotherapeutic agents

1. Alkylating agents - electron deficient side chains which interact with DNA
 - (i) Nitrogen mustards - cyclophosphamide, melphalan and chlorambucil
 - (ii) Nitrosoureas - BCNU, CCNU and methyl-CCNU
 - (iii) Others - busulphan, thio-TEPA and procarbazine
2. Antimetabolites - inhibit nucleic acid synthesis directly or indirectly
 - (i) Methotrexate - analogue of folic acid causes cessation of DNA synthesis
 - (ii) 5-fluorouracil - analogue of pyrimidine bases uracil and thymidine interferes with RNA processing and DNA synthesis
 - (iii) cytosine arabinoside - competitive inhibition of DNA polymerase
 - (iv) purine antimetabolites - mercaptopurine and thioguanine interferes with DNA synthesis
3. Natural products
 - (i) anthracyclines - planar multi ring structures that intercalate into DNA - inhibits DNA and RNA synthesis
 - a. Doxorubicin
 - b. Actinomycin
 - c. Bleomycin
 - (ii) vinca alkaloids - bind to tubulin and disrupt the mitotic spindle
 - a. Vinblastine
 - b. Vincristine
4. Miscellaneous
 - (i) Cisplatin - cross links DNA-DNA and DNA-protein
 - (ii) Hydroxyurea - inhibits ribonucleotide reductase enzymes that convert ribose nucleotides to deoxyribose nucleotides
 - (iii) L-asparaginase - degradation of L-asparagine

Systemic effects of chemotherapy

1. Bone marrow suppression - loss of rapidly proliferating lineages. Granulocytes > platelets > red blood cells
2. Intestinal ulceration - inhibition of production of epithelial cells leading to loss of function and ulceration
3. Partial or complete loss of hair

4. Inhibition of germ cell development - spermatozoa and oocytes
5. Cessation of ovarian function
6. Nausea and vomiting
7. Mutation of DNA and chromosomal damage - can lead to second malignancies especially leukaemias

Types of radiation

1. X-rays are machine-generated electromagnetic radiations of zero mass and charge
2. γ -rays are similar to X-rays but are generated by the spontaneous decay of radio-active isotopes
3. α -Particles have a mass of 4 and a positive charge of 2 equivalent to a helium nucleus. They are produced by the nuclear reactions of high-energy electromagnetic radiation and the decay of radio-active elements, such as radium and uranium
4. β -Particles are electrons having negligible mass and one negative charge, which in medical usage are produced by decay of certain isotopes

Mechanisms of action

1. Direct action

One mode of action may be a direct ionisation of part of a molecule by the absorbed energy

2. Indirect action

A more likely explanation is that highly reactive free radicals, such as uncharged hydrogen atoms or OH^\bullet radicals, are formed which subsequently attack intracellular macromolecules causing cell injury

Cellular effects

1. Very high dosage leads to rapid cell death
2. Lower doses by affecting DNA synthesis reduce mitotic activity
3. Chromosome abnormalities may appear after cell division

Tissue effects

1. Skin, with increasing dosage
 - (i) Erythema
 - (ii) Abnormalities in pigmentation
 - (iii) Hyperkeratosis
 - (iv) Loss of skin appendages
 - (v) Epidermal atrophy
 - (vi) Dermal fibrosis
 - (vii) Ulceration
2. Haemopoietic system

- (i) Transient pancytopenia
- (ii) Aplastic anaemia
- (iii) Leukaemic change
3. Testis
 - (i) Tubular atrophy and hyalinisation
 - (ii) Loss of spermatogonia
4. Ovary
 - (i) Destruction of follicles
 - (ii) Cessation of menstruation
5. Lungs
 - (i) Pulmonary congestion and oedema
 - (ii) 'Hyaline membrane' reaction
 - (iii) Interstitial fibrosis
 - (iv) Bronchial carcinoma following inhalation of radio-active substances, e.g. miners of Schneeberg (pitchblende)
6. Kidneys
 - (i) Glomerular fibrosis
 - (ii) Vascular sclerosis

These changes may produce malignant hypertension
7. Gastrointestinal tract
 - (i) Mucosal oedema and ulceration
 - (ii) Vascular hyalinisation
 - (iii) Submucosal fibrosis
 - (iv) Glandular atrophy
 - (v) Fibrosis of the muscularis propria
 - (vi) Stricture formation
8. Salivary glands - decreased function leads to
 - (i) Xerostomia
 - (ii) Infections of the mouth
 - (iii) Dental caries
9. Liver
 - (i) Diffuse fibrosis
 - (ii) Venocclusive disease

10. Bone
 - (i) 'Radionecrosis'
 - (ii) Osteogenic sarcoma from radium and mesothorium
11. Nervous system
 - (i) White matter oedema
 - (ii) Astrocyte hypertrophy and hyperplasia
 - (iii) Vascular hyalinisation
 - (iv) Microcalcification
 - (v) Necrosis probably mediated by small vessel fibrosis

Whole body irradiation

With increasing dosage the effects can be grouped into three main syndromes:

1. Haemopoietic syndrome (4-10 Gy)
 - (i) Lymphopenia
 - (ii) Granulocytopenia
 - (iii) Thrombocytopenia

Death may result from infection or haemorrhage
2. Gastrointestinal syndrome (10-15 Gy)
 - (i) Villous atrophy
 - (ii) Mucous depletion

Death is due to fluid and electrolyte imbalance, infection, or nutritional impairment
3. Cerebral syndrome (>100 Gy)

Nerve cells are destroyed by either direct radiation injury or secondary to increased vascular permeability with oedema and pressure damage. Nausea and vomiting are followed by tremors and convulsions with death 1-2 days after exposure.

If the patient survives the acute phase then there are a number of possible late effects:

 1. Marrow aplasia
 2. Cataracts
 3. Developmental abnormalities in the fetus
 4. Leukaemia, skin cancer, or cancer in other organs such as thyroid, bone, larynx, etc.
 5. General effects - premature ageing
 6. Pneumonitis; nephritis; myocarditis and pericarditis

Sensitivity of tumours to irradiation

The following facts are important:

1. Tissue of origin
2. Degree of differentiation, usually inversely proportional to the sensitivity
3. Mitotic activity, directly proportional to the sensitivity
4. Vascularity of the stroma and general blood supply, which is related to 5
5. Hypoxia reduces the sensitivity of tumours to radiation, conversely hyperbaric oxygen has been used to enhance radiotherapy
6. Recurrent tumours are insensitive as they are probably derived from the most radioresistant cells of the primary neoplasm.

Other therapeutic agents

1. Modulation of oestrogens
 - (i) Tamoxifen - competes with oestradiol for the high affinity oestrogen receptor
 - (ii) Progestational agents - medroxyprogesterone
 - (iii) Aminoglutethimide - inhibits synthesis of oestrogen
2. Modulation of androgens - cyproterone acetate, flutamide and synthetic gonadotro-releasing agonists
3. Biological response modifiers (cf. cytokines) - therapeutic agents which help the host's defence mechanisms to act against cancer cells
 - (i) Interferons
 - (ii) Interleukins-1 and 2
 - (iii) Tumour necrosis factors
4. Immunotherapy (mainly experimental)
 - (i) Active immunotherapy
 - a. Administration of inactivated tumour cells
 - b. Administration of immune stimulants such as BCG or Corynebacterium parvum vaccine or levamisole
 - (ii) Passive immunotherapy
 - a. Administration of monoclonal antibodies or fragments of antibodies
 - b. Injection of cloned cytotoxic T-cells or natural killer cells

18. Iatrogenic disease

Although logically the concept of iatrogenic disease should include the adverse effects of investigation and other medical or surgical procedures, the major problem centres around the adverse effects of pharmaceutical agents, biological agents such as vaccines and blood products, and the 'side-effects' of chemotherapy and irradiation. The latter are covered under cancer therapy.

DRUG-INDUCED DISEASE

Adverse reactions to drugs result from either a predictable toxic effect usually related to the dosage level, or an unexpected effect which may have an immunological mechanism or be described as 'idiosyncratic'. Under special circumstances drugs may be teratogenic (i.e. producing maldevelopment in the fetus) or mutagenic.

A. Predictable toxicity is the manifestation of secondary pharmacological actions.

Drugs injure cells either by:

1. Direct toxicity, e.g.
 - (i) Tetracycline producing fatty liver
 - (ii) Oxygen in high concentration giving rise to hyaline membranes in the lung and retrolental fibroplasia in the eye
 - (iii) Aspirin injury to the gastric mucosa
2. Metabolic products
e.g. Paracetamol metabolism following an overdose results in liver necrosis
Certain groups of patients are at increased risk from the predictable toxic or side-effects of drugs:
 1. Age - the very old and the very young are less tolerant of drugs
 2. Genetically determined defects of metabolism:
 - (i) Slow acetylation leads to persistence of drugs
 - (ii) Pseudocholinesterase deficiency prolongs the effects of neuromuscular blockers
 - (iii) Glucose-6-phosphatase deficiency can give rise to haemolytic anaemia during treatment with sulphonamides, anti-malarials
 3. Impaired drug metabolism
 - (i) Liver disease
 - (ii) Immaturity, i.e. in the neonate
 4. Reduced drug excretion
 - (i) Renal failure
 - (ii) In neonates

B. Immunological mechanisms

1. Hypersensitivity reactions - drugs may function as allergens but most only act as antigens after combining with a host macromolecule, usually protein, i.e. they act as haptens. All the classical hypersensitivity reactions can be provoked by drugs:
 - (i) Type I
 - a. Anaphylactic reactions - e.g. sudden death after parenteral injection of penicillin
 - b. Atopic reactions - e.g. urticaria and bronchospasm
 - (ii) Type II - most commonly seen as haemolytic reactions following attachment of the drug or a metabolite to the red cell membrane
 - (iii) Type III - immune complex formation leading to serum sickness'-type reactions
 - (iv) Type IV - cell-mediated reactions are frequently seen in the skin where a drug-protein complex is antigenic to T-cells, so-called 'contact dermatitis'
2. Immunosuppression - drugs which have actions on immune mediators, for example corticosteroids, azathioprine, cyclophosphamide, etc., may increase susceptibility to secondary infection and, in rare instances, predispose to neoplasia

C. Idiosyncrasy

This is an inherent qualitatively abnormal reaction to a drug. Most instances are inexplicable, but some patients are genetically predisposed to such reactions:

1. Mepacrine induced haemolytic anaemia in patients with glucose-6-phosphatase deficiency
2. Drug induced porphyria in genetically susceptible individuals

D. Teratogenesis

Congenital malformations induced by drugs taken during pregnancy, e.g. thalidomide use resulting in absence of limbs

E. Mutagenesis and carcinogenesis

As would be expected with adequate animal testing of drugs, these potential hazards are rarely encountered although it is possible for recessive point mutations to occur without these becoming clinically apparent. The role of drugs in carcinogenesis is difficult to establish. Neoplasms should develop at the sites of maximum drug concentration, e.g. transitional cell carcinomas in the renal pelvis and bladder in patients taking excessive quantities of phenacetin-containing analgesics, liver neoplasms occurring when carcinogens are generated following hepatic metabolism. Of historical interest neoplasms have occurred at the sites of deposition of drugs or other agents, e.g. skin cancers resulting from arsenical administration, liver sarcomas resulting from thorotrast deposition (a radio-active substance used in radiology).

ADVERSE EFFECTS OF BIOLOGICAL AGENTS

Many reactions provoked by animal and human products are being eliminated by the use of biologically engineered compounds, e.g. interferon, insulin, growth hormone. Complications arising from the use of serum and vaccines include:

1. Human sera and blood products
 - (i) Infection - HIV, viral hepatitis, cytomegalovirus
 - (ii) Hypersensitivity reactions
2. Animal sera
 - (i) Hypersensitivity reactions - Arthus reactions, serum sickness, anaphylaxis
 - (ii) Neurological effects - encephalitis, Guillain-Barré polyneuritis
3. Live vaccines
 - (i) Local or systemic spread, e.g. BCG infection, progressive or generalised vaccinia
 - (ii) Neurological effects, e.g. post-vaccinial encephalitis
4. Toxoids and dead vaccines
 - (i) Hypersensitivity reactions - mainly local immediate and cell-mediated types
 - (ii) Neurological effects - possible role of pertussis vaccine in encephalitis

19. Alimentary system

SALIVARY GLANDS

A. Congenital

1. Agenesis of one or more glands
2. Atresia of a duct

B. Acute inflammation

1. Acute suppurative sialadenitis
2. Mumps
3. Cytomegalic inclusion disease

C. Chronic inflammation

1. Non-specific, usually in association with calculi
2. Sjögren's syndrome
 - (i) Keratoconjunctivitis sicca
 - (ii) Xerostomia
 - (iii) Rheumatoid arthritis
 - (iv) Enlargement of salivary glands
3. Sarcoidosis
4. Tuberculosis
5. Actinomycosis
6. Syphilis

7. Mikulicz's disease (benign lymphoepithelial lesion)

D. Mechanical disorders

1. Mucocoele resulting from rupture of a duct
2. Ranula result from obstruction of a sublingual gland
3. Obstruction by calculus - sialolithiasis

E. Benign tumours

1. Pleomorphic adenoma (mixed parotid tumour)
2. Warthin's tumour
3. Monomorphic adenoma

F. Malignant tumours

1. Mucoepidermoid carcinoma
2. Adenoid cystic carcinoma
3. Carcinoma arising from a pleomorphic adenoma
4. Adenocarcinoma
5. Lymphoma

MOUTH AND PHARYNX

A. Congenital

1. Cleft lip and palate
2. Microstomia and macrostomia
3. Microglossia and macroglossia
4. Median rhomboid glossitis
5. 'Bifid' and 'scrotal' tongue

B. Acute inflammation

1. Non-specific gingivitis
2. Vincent's infection (acute necrotising ulcerative gingivitis)
3. Aphthous stomatitis
4. Herpetic gingivo-stomatitis
5. Moniliasis (thrush)
6. Cancrum oris (noma)

C. Chronic inflammation

1. Chronic desquamative gingivitis
2. Tuberculosis

3. Actinomycosis
4. Syphilis

D. Benign tumours and tumour-like conditions

1. 'Congenital epulis'
2. Giant-cell epulis (probably reactive)
3. Angiomatous 'tumour' of pregnancy (reactive)
4. Fibroma
5. Haemangioma
6. Squamous papilloma
7. Lymphangioma
8. Granular-cell myoblastoma

E. Leucoplakia

1. Aetiology

- (i) Poor dental hygiene
- (ii) Smoking
- (iii) Trauma from rough teeth
- (iv) Syphilis

2. Microscopic appearances

- (i) Hyperplasia of squamous epithelium
- (ii) Hyperkeratosis
- (iii) Chronic inflammatory reaction
- (iv) Dysplasia (may be absent)

F. Malignant tumours

1. Squamous carcinoma
2. Adenocarcinoma (mucous/salivary glands)
3. Intermediate or 'transitional-cell' carcinoma (pharynx)
4. Undifferentiated carcinoma with lymphoid stroma 'lymphoepithelioma' (nasopharynx)
5. Malignant melanoma
6. Fibrosarcoma
7. Lymphoma (tonsils)

OESOPHAGUS

A. Congenital

1. Agenesis (extremely rare)
2. Atresia, usually associated with a fistula into the trachea
3. Stenosis
4. Gastric heterotopia

B. Inflammation

1. Reflux oesophagitis

Rare causes

2. Viral oesophagitis, e.g. herpes simplex and CMV
3. Fungal oesophagitis
 - (i) Candidiasis
 - (ii) Aspergillosis
4. Uraemic oesophagitis
5. Corrosive chemical ingestion
6. Plummer-Vinson syndrome - resulting from long-standing iron deficiency
- 7 Tuberculosis
8. Crohn's disease
9. Chagas' disease

C. Vascular disorders

Oesophageal varices - dilatation of submucosal veins resulting from portal hypertension

D. Mechanical disorders

1. Diverticula
 - (i) Traction
 - (ii) Pulsion
2. Obstruction resulting from:
 - (i) Stricture - chronic peptic ulceration or corrosive ingestion
 - (ii) Carcinoma
 - (iii) Achalasia (cardiospasm)
 - (iv) Progressive systemic sclerosis
 - (v) Mucosal webs
 - (vi) Congenital stenosis

SCIO

CE measures treats

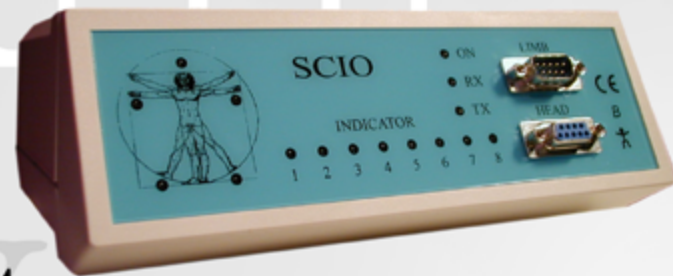

The SCIO Universal Electrophysiological Biofeedback System can safely measure over the skin (transcutaneous) skin electro-potential down to the micro-volt range. Virtual and mathematical calculations of the attained data can provide CNS (Central Nervous System) biofeedback data, so as to include (simple EEG [electroencephalography], 3-pole ECG [simple stress electrocardiography], global transcutaneous EMG [electromyography]).

The system can measure the transcutaneous skin resistance by application of a medical safe micro-current voltametric pulse, so as to measure GSR [galvanic skin response] and TVEP [transcutaneous voltametric evoked potential].

The system is designed for the detection of stress and reduction of stress through CNS biofeedback data or stress lifestyle questionnaires. The stress and lifestyle questionnaires provide educational feedback through library referenced functions. And the device can be used for the treatment of muscular re-education from injury, muscle weakness, sport muscular enhancement or various dystonia. The applied voltametric pulse can be used to detect and affect in established modalities such as pain (TENS [transcutaneous electro nerval stimulation]), trauma/wound healing, charge stability imbalance, redox potential and electrophysiological reactivity.

The device after 20 years of use is quality tested, clinically evaluated and scientifically validated as safe and effective.

If you need more information on the SCIO and purchase details please get in touch with us

Maitreya Kft.
 tel: +3613036043
 web: www.qxsubspace.com
 e-mail: info@qxsubspace.com



3. Rupture
 - (i) Mucosal (Mallory-Weiss syndrome)
 - (ii) Full thickness - oesophageal perforation
4. Hiatus hernia
 - (i) Sliding type
 - (ii) Para-oesophageal perforation

E. Benign tumours

1. Leiomyoma
2. Fibroma
3. Lipoma
4. Granular cell myoblastoma

F. Malignant tumours

1. Carcinoma of the oesophagus

Predisposing factors, many of which are speculative

- (i) Tobacco and alcohol
- (ii) Barrett's metaplasia
- (iii) Anatomical abnormalities, e.g. hiatus hernia, achalasia
- (iv) Plummer-Vinson syndrome (post cricoid)
- (v) Following corrosive injury

Types

- (i) Squamous cell, including polypoid or spindle cell variants
- (ii) Adenocarcinoma, arising from-
 - a. Metaplastic columnar epithelium in the lower oesophagus (Barrett's oesophagus)
 - b. Gastric type epithelium in lower 2 cm
- (iii) Oat-cell carcinoma (rare)
- (iv) Adenosquamous carcinoma (rare)

Spread

- (i) Direct to:
 - a. Mediastinum
 - b. Trachea or main bronchi
 - c. Lung
 - d. Aorta or heart (uncommon)

- (ii) Metastasis to:
 - a. Regional lymph nodes
 - b. Liver
 - c. Lungs
 - d. Adrenal

Prognosis

5 year survival is below 10%

The remaining tumours are all very rare:

2. Sarcoma
 - (i) Leiomyosarcoma
 - (ii) Fibrosarcoma
3. Malignant melanoma
4. Carcino-sarcoma

STOMACH

A. Congenital

1. Diaphragmatic hernia
2. Congenital Pyloric stenosis

B. Inflammations

Acute haemorrhagic gastritis

Causes

- (i) Alcohol excess
 - (ii) Salicylates and other drugs
 - (iii) Bile reflux
 - (iv) Staphylococcal exotoxin in contaminated food
 - (v) Irritant chemicals/corrosives
 - (vi) After major surgery or trauma
2. Acute neutrophilic gastritis - the acute phase of Helicobacter pylori infection of the stomach
 3. Chronic gastritis
 - (i) Autoimmune gastritis
 - a. Anti-parietal cell and anti-intrinsic factor antibodies
 - b. Sensitised T-cell attack on corpus glands
 - c. Glandular atrophy restricted to the corpus

- d. Intestinal metaplasia
 - (ii) H. pylori-associated chronic gastritis, pan-gastritis type
 - a. Involves entire stomach
 - b. Surface epithelial degeneration
 - c. Active chronic inflammation
 - d. Depending on the duration of infection and the presence of other factors such as bile reflux and dietary irritants, atrophy and intestinal metaplasia are seen in the later stages.
 - e. Increased risk of gastric ulcer and gastric cancer
 - (iii) H. pylori-associated chronic gastritis, antrum predominant type
 - a. Active chronic inflammation in the antrum
 - b. Corpus is normal or shows only minor involvement
 - c. occurs in people with acid-induced gastric metaplasia in the duodenum
 - d. Strong association with duodenal ulceration
 - (iv) Reflux or chemical type

Causes

- a. Entero-gastric bile reflux
- b. NSAID usage
- c. Alcohol (possible)

Features

- a. Foveolar hyperplasia
 - b. Lamina propria oedema
 - c. Vasodilatation/congestion
 - d. Paucity of inflammatory cells
4. Lymphocytic gastritis
 - (i) Large numbers of intra-epithelial lymphocytes
 - (ii) Maximal in the corpus
 - (iii) Enlarged mucosal folds
 - (iv) Aphthoid ulcers
 5. Hypertrophic gastritis (Ménétrier's disease)
 - (i) Rugal hypertrophy
 - (ii) Cystic dilatation of glands
 - (iii) Strands of muscularis mucosae in lamina propria
 6. Eosinophilic gastritis

7. Granulomatous gastritis

- (i) Crohn's disease
- (ii) Sarcoidosis
- (iii) Reaction to H. pylori
- (iv) Foreign material, e.g. food particles in the mucosa
- (v) Isolated (i.e. idiopathic)

C. Acute ulceration and erosions

1. Related to acute gastritis

- (i) Aspirin
- (ii) Alcohol excess
- (iii) Bile reflux

2. Related to shock

- (i) Severe burns, major trauma (Curling's ulcers)
- (ii) Cerebrovascular accidents
- (iii) Septicaemia
- (iv) ACTH or corticosteroid therapy

D. Chronic peptic ulcers

1. Sites

- (i) Lesser curve of stomach
- (ii) First part of duodenum
- (iii) Lower oesophagus
- (iv) Gastroenterostomy margins
- (v) Meckel's diverticulum
- (vi) Remainder of duodenum and jejunum in Zollinger-Ellison syndrome

2. Predisposing factors Gastric ulceration

- (i) Chronic H. pylori-associated pan-gastritis
- (ii) NSAID use
- (iii) Alcohol abuse
- (iv) Bile reflux

Duodenal ulceration

- (i) Helicobacter-associated chronic gastritis - antral predominant
- (ii) Gastric metaplasia in the duodenum

3. Pathogenesis

Chronic peptic ulcers occur when the digestive action of acid and pepsin overcome the natural defences of the mucosa. Duodenal ulcers develop when:

- (i) Gastric metaplasia appears in the duodenum as a consequence of excessive acid output
- (ii) Subsequent H. pylori infection causes active chronic inflammation in the metaplastic mucosa
- (iii) Active chronic inflammation reduces mucosal resistance and erosions and ulceration ensue

Gastric ulcers are multifactorial

- (i) Long-standing chronic gastritis (H. pylori-associated) reduces mucosal resistance to acid/pepsin
- (ii) In some cases NSAIDs act synergistically with H. pylori-associated mucosal damage to produce ulcers
- (iii) Mucosa which has undergone intestinal metaplasia may be more susceptible to acid attack

4. Complications

- (i) Perforation
- (ii) Haemorrhage
- (iii) Stenosis

a. Pyloric

b. Hour-glass deformity

- (iv) Malignant change (rare)

E. Benign tumours and polyps

1. Hyperplastic (regenerative) polyps

2. True neoplasms

- (i) Adenoma

- (ii) Stromal tumours (difficult to predict behaviour)

3. Hamartomas and heterotopias

- (i) 'Cystic hamartomatous polyps'- simple fundic polyps

- (ii) Heterotopic pancreas

- (iii) Adenomyoma (myo-epithelial hamartoma)

- (iv) Peutz-Jeghers' polyps

- (v) Cronkhite-Canada syndrome

a. Polyposis of the stomach and intestines

b. Abnormal skin pigmentation

Nail dystrophy

d. Baldness

F. Malignant tumours

1. Carcinoma

Precancerous conditions

a. H. pylori-associated chronic gastritis with atrophy and intestinal metaplasia

b. Adenomatous polyps (rare outside Japan)

(Chronic peptic ulcer rarely give rise to gastric carcinomas, <1%)

Gross types

(i) Nodular

(ii) Ulcerative

(iii) Polypoid or fungating

(iv) Linitis plastica

Microscopic appearances

(i) Intra-mucosal 'tubular' or 'signet-ring cell' types

(ii) Adenocarcinoma

a. Intestinal type

b. Diffuse type

c. Mixed showing well, moderate or poor differentiation

(iii) Anaplastic carcinoma

Spread

(i) Direct

a. Confined to mucosa or submucosa = early gastric cancer (even if lymph nodes involved)

b. Spread into muscularis propria and beyond advanced gastric cancer

(ii) Lymphatic to nodes along lesser and greater curve

(iii) Blood spread to liver

(iv) Transcoelomic to omentum, peritoneum and ovaries (Krukenberg spread)

2. Carcinoid tumour - increased prevalence in pernicious anaemia

3. Lymphoma - usually maltoma (B-cell lymphoma)

4. Stromal tumours of smooth muscle or neural origin

SMALL INTESTINE

A. Congenital

1. Duodenal diverticula

2. Diverticulosis of jejunum and ileum

3. Meckel's diverticulum

4. Atresia

5. Failures of rotation

B. Inflammation/ulceration

1. Crohn's disease

A chronic granulomatous disease mainly affecting the small intestine but can involve any part from mouth to anus. The aetiology is unknown but there is increasing evidence pointing towards infection by Mycobacterium paratuberculosis.

Gross features

(i) 'Hosepipe' thickening of wall

(ii) Ulcers - aphthoid or linear

(iii) Deep fissures

(iv) 'Cobblestone' mucosa

(v) 'Skip' lesions (i.e. segmental involvement)

(vi) Enlarged lymph nodes

Microscopic appearances

(i) Granulomas (sarcoid-type)

(ii) Transmural inflammation

(iii) Aggregated pattern of inflammatory cells

(iv) Submucosal oedema, lymphangiectasia, and fibrosis

(v) Fissure ulcers

(vi) Neuromatoid hyperplasia

Complications

(i) Malabsorption

(ii) Obstruction

(iii) Fistula formation

(iv) Perforation

(v) Haemorrhage

(vi) Liver disease - peri-biliary fibrosis

- (vii) Skin lesions
- (viii) Ocular inflammation
- (ix) Malignancy
- 2. Infections
 - (i) Cholera
 - (ii) E. coli infections in infants
 - (iii) Typhoid/paratyphoid
 - (iv) Staphylococcal enterocolitis
 - (v) Tuberculosis
 - (vi) Actinomycosis
 - (vii) Yersinia pseudotuberculosis (acute terminal ileitis)
 - (viii) Viral diseases parvoviruses and reoviruses
 - (ix) Whipple's disease
 - (x) Giardiasis - found more commonly in:
 - a. Childhood
 - b. Malnutrition
 - c. Following gastrectomy
 - d. Pancreatic disease
 - e. Hypogammaglobulinaemia
 - f. Nodular lymphoid hyperplasia
 - g. Dysgammaglobulinaemia
 - h. Travellers (Leningrad, Indian subcontinent, etc)

C. Malabsorption

Due to abnormal small intestinal function

- 1. Villous atrophy

Terminology

- (i) Villous architecture
 - a. Mild, moderate or severe partial villous atrophy
 - b. Total villous atrophy
- (ii) Crypt cellularity and mitotic activity
 - a. Crypt hyperplasia
 - b. Crypt hypoplasia

Major causes of crypt hyperplastic villous atrophy

- (i) Coeliac disease caused by an abnormal response of the small intestinal mucosa to an unknown peptide found in the wheat protein, gluten. This is likely to be immunologically mediated.

Immunological findings

- a. Mucosal plasma cells show diminished IgA, and increased IgM secretion
- b. IgM is decreased in the serum whilst IgA is increased
- c. Features of immune dysfunction such as splenic atrophy and impaired lymphocyte transformation
- d. The serum may contain IgM antibodies to certain fractions of gluten
- e. IgA deposited on basement membrane following gluten challenge. IgG deposits found in untreated coeliacs

Increased proportion of g/b T-cells in the epithelium

Microscopic features

- a. Total or severe partial villous atrophy
- b. Cuboidal surface epithelium with palisading of nuclei and indistinct brush border
- c. Heavy infiltration of epithelium by lymphocytes
- d. Increase in lymphocytes and plasma cells in lamina propria

Complications

- a. Enteropathy-associated T-cell lymphoma
- b. Ulcerative jejunitis
- c. Adenocarcinoma of the small intestine
- d. Extra-intestinal malignancy, e.g. carcinoma of the oesophagus
- (ii) Tropical sprue
- (iii) Stasis syndrome with bacterial overgrowth
- (iv) Post-infective malabsorption syndrome
- (v) Kwashiorkor
- (vi) Severe chronic duodenitis

Causes of crypt hypoplastic villous atrophy

- (i) Pernicious anaemia
- (ii) Folic acid deficiency
- (iii) Carcinomatosis
- (iv) Hypopituitarism
- (v) Irradiation

2. Biochemical disorders giving rise to malabsorption
 - (i) Sucrase-isomaltase deficiency
 - (ii) Lactase deficiency
 - (iii) Monosaccharide malabsorption
 - (iv) Hartnup disease
 - (v) Cystinuria
 - (vi) Congenital chlorodiarrhoea
 - (vii) Abeta-lipoproteinaemia
 3. Disease of the intestinal wall
 - (i) Amyloidosis
 - (ii) Radiation injury
 - (iii) Collagen disease
 - (iv) Crohn's disease
 4. Altered bacterial flora
 - (i) Stagnant loop syndrome
 - (ii) Jejunal diverticulosis
 - (iii) Multiple strictures as in Crohn's disease
 - (iv) Fistulae
 5. Miscellaneous causes
 - (i) Whipple's disease
 - (ii) Lymphangiectasia
- D. Vascular disorders**
1. Mucosal vessels
 - (i) Hereditary haemorrhagic telangiectasia (Osler-Rendu-Weber syndrome)
 2. Mesenteric arteries
 - (i) Thrombosis/embolus
 - (ii) Atherosclerosis
 - (iii) Fibro-muscular hyperplasia
 - (iv) Polyarteritis nodosa
 3. Mesenteric veins
 - (i) Thrombosis
 - (ii) Strangulation (in later stages leads to arterial occlusion)

- Arterial and venous occlusion results in haemorrhagic infarction
4. Non-occlusive ischaemia resulting from
 - (i) Cardiac failure
 - (ii) Shock
 - (iii) Drug-induced vasoconstriction

E. Mechanical disorders

Obstruction of the small intestine

Causes

1. Hernias
2. Adhesions
3. Neoplasms
4. Intussusception
5. Volvulus
6. Strictures, congenital or acquired
7. Atresia
8. Gall stones or foreign body (including food bolus)
9. Meconium plug (mucoviscidosis)

Obstruction may also result from mesenteric thrombosis and neurogenic paralytic ileus

F. Benign tumours - these are all rare

1. Adenoma - mainly peri-ampullary
2. Lipoma
3. Haemangioma (may be part of the Osler-Rendu-Weber syndrome)
4. Lymphangioma
5. Peutz-Jeghers' polyps (hamartomas)
6. Stromal tumour

G. Malignant tumours

1. Carcinoid tumour
2. Lymphoma Predisposed to by:
 - (i) Coeliac disease
 - (ii) Alpha-chain disease
 - (iii) Selective IgA deficiency
 - (iv) Common variable hypogammaglobulinaemia

- (v) Crohn's disease
- 3. Malignant stromal tumour
- 4. Adenocarcinoma (rare) Predisposed to by:
 - (i) Crohn's disease
 - (ii) Coeliac disease
 - (iii) Familial adenomatous polyposis

APPENDIX

A. Inflammation

1. Acute non-specific

Predisposing factors (act mainly by causing obstruction)

- (i) Lymphoid hyperplasia
 - a. Physiological
 - b. Measles and other viral diseases
- (ii) Faecalith/foreign bodies/food residues
- (iii) Mucosal oedema
- (iv) Diverticulosis of the appendix
- (v) Carcinoid tumour
- (vi) Threadworms

Complications

- (i) Perforation leading to:
 - a. Generalised peritonitis
 - b. Appendicular abscess
 - c. Fistula formation
- (ii) Suppurative pylephlebitis and liver abscess
- (iii) Septicaemia
- (iv) Chronic appendicitis
- (v) Mucocoele which may rupture and produce pseudomyxoma peritonei
- 2. Specific bacterial infections
 - (i) Yersinia pseudotuberculosis appendicitis
 - (ii) Typhoid
 - (iii) Tuberculosis
 - (iv) Actinomycosis

- 3. Crohn's disease
- 4. Starch-grain granulomatosis
- 5. Polyarteritis nodosa
- 6. Eosinophil granuloma

B. Neoplasms

- 1. Carcinoid tumour
- 2. Adenoma
- 3. Adenocarcinoma
- 4. Lymphoma

LARGE INTESTINE

A. Congenital

- 1. Atresia including imperforate anus
- 2. Stenosis
- 3. Duplication
- 4. Hirschsprung's disease - aganglionosis

B. Inflammation

- 1. Infective colitis Features
 - (i) Crypt pattern preserved
 - (ii) Predominantly neutrophil Polymorph infiltrate
 - (iii) Poorly formed 'mucoid' crypt abscesses
 - (iv) Marked surface epithelial degeneration and crypt hyperplasia

Causes

- (i) Bacterial
 - a. Campylobacter jejuni
 - b. Bacillary dysentery (shigellosis)
 - c. Salmonella food-poisoning
 - d. Tuberculosis
 - e. Staphylococcal enterocolitis
 - f. Gonorrhoea
 - g. Enterotoxigenic E coli
- (ii) Viral / Chlamydial
 - a. CMV

- b. Lymphogranuloma venereum
- (iii) Others
 - a. Amoebic dysentery
 - b. Schistosomiasis
 - c. Balantidiasis
 - d. Rectal syphilis

2. Ulcerative colitis

A chronic inflammatory process of unknown aetiology characterised by relapses and remissions leading to persistent diarrhoea and debility.

Sites

Usually starts in rectum and spreads proximally to involve a variable length of colon. Frequently the entire colon is involved.

Gross features

- (i) Continuity of involvement
- (ii) Confluent irregular mucosal ulceration
- (iii) Pseudopolyps¹- residual inflamed mucosa
- (iii) Intense vascularity

Microscopic features

- (i) Continuous inflammation maximal in the mucosa
- (ii) Congestion and vasodilatation
- (iii) Crypt abscesses
- (iv) Undermining ulcers and inflammatory polyps
- (v) Crypt atrophy and distortion
- (vi) Mucin depletion
- (vii) Paneth-cell metaplasia
- (viii) Pre-malignant dysplasia may be present in long-standing cases

Complications

- (i) Haemorrhage
- (ii) Anaemia
- (iii) Electrolyte disturbance
- (iv) Perforation
- (v) Toxic dilatation
- (vi) Malignant change - adenocarcinoma, rarely a malignant carcinoid or small cell carcinoma

- (vii) Extra-intestinal disease
 - a. Skin lesions - pyoderma gangrenosum, erythema nodosum
 - b. Arthritis/ankylosing spondylitis
 - c. Liver disease - chronic pericholangitis
 - d. Eye disease - iritis, uveitis, episcleritis
 - e. Biliary tract - sclerosing cholangitis, carcinoma
- 3. Crohn's colitis
- 4. Irradiation colitis
- 5. Antibiotic-associated (including pseudomembranous colitis)
- 6. Mucosal prolapse syndrome - including solitary ulcer
- 7. Microscopic or lymphocytic colitis
- 8. Collagenous colitis
- 9. Diversion colitis

C. Vascular disorders

- 1. Ischaemia

The causes of ischaemia are the same as those in the small intestine.

Ischaemia results in:

- (i) Infarction
- (ii) Ischaemic colitis
- (iii) Stricture

- 2. Haemorrhoids.

Varicosities of the superior and inferior rectal veins.

Causes

- (i) Chronic constipation
- (ii) Heavy physical work
- (iii) Pregnancy
- (iv) Pelvic tumours
- (v) Portal hypertension
- (vi) Rectal carcinoma
- 3. Angiodysplasia - usually in the caecum

D. Mechanical disorders

1. Diverticular disease

Outpouchings of the large bowel mucosa through the muscle coat develop in response to prolonged increases in intraluminal pressure. These diverticulae form at the sites of lympho-glandular complexes in the mucosa which overlie defects in the muscularis mucosae. The usual segment to be affected is the sigmoid colon, but infrequently they can be found in the proximal colon. The diverticulae become secondarily infected, probably following minor trauma, and the ensuing diverticulitis can lead to abscess formation and generalised peritonitis.

2. Volvulus

3. Herniation

4. Intussusception

E. Tumour-like conditions

(i) Peutz-Jeghers' polyps

(ii) Juvenile polyposis

F. Benign tumours and polyps

1. Epithelial

(i) Tubular adenoma (adenomatous polyp)

(ii) Tubulo-villous adenoma

(iii) Villous adenoma

(iv) Metaplastic polyps

2. Lymphoid

(i) Benign lymphoid polyp

3. Connective tissues

(i) Lipoma

(ii) Stromal tumours

(iii) Ganglioneuroma

(iv) Haemangioma

G. Malignant tumours

1. Carcinoma

Pre-malignant conditions

(i) Adenomas - adenoma-carcinoma sequence

a. Familial adenomatous polyposis

b. Hereditary non-polyposis colorectal cancer syndrome

(ii) Ulcerative colitis - dysplasia-carcinoma sequence

Aetiology

(i) Genetic - familial tendency

(ii) Dietary factors

a. ? Bile salts and anaerobic organisms

b. ? Low residue food

Gross features

(i) Annular ulcerated

(ii) Polypoid/fungating

Microscopic appearances

(i) Adenocarcinoma

(ii) Muroid (colloid) carcinoma

(iii) Small-cell undifferentiated carcinoma and in the lower rectum and anal canal

(iv) Squamous carcinoma (including basaloid variety)

Spread

Direct and lymphatic: Dukes' classification

- Stage A - does not penetrate through the muscle layer of the colon/rectum
- Stage B - extends into surrounding fat but there is no involvement of regional lymph nodes
- Stage C1 - secondary deposits present in the regional lymph nodes
- Stage C2 - involvement of the highest resected lymph node
- Stage D - distant metastases

Blood spread is mainly to the liver

Complications

(i) Obstruction

(ii) Perforation

(iii) Fistula formation

(iv) Haemorrhoids (with rectal carcinoma)

(v) Anaemia

(vi) Diarrhoea

2. Carcinoid tumour

3. Lymphoma, including malignant lymphoid polyposis

4. Sarcoma

(i) Malignant stromal tumour

- (ii) Liposarcoma
- 5. Malignant melanoma (anal region)

20. Liver, gall-bladder and pancreas

DISEASES OF THE LIVER

A. Congenital

1. Accessory lobes - Riedel's lobe
2. Congenital cystic disease (found in association with polycystic kidneys)
3. Congenital hepatic fibrosis (some cases are associated with renal cysts)
4. (a-I-antitrypsin deficiency)

B. Infections

Viral hepatitis

Types

- (i) Hepatitis A - caused by an RNA enterovirus, 2-6 weeks incubation, epidemic, faecal-oral spread
- (ii) Hepatitis B - DNA hepadna Virus, 2-6 months incubation, parenteral, placental or venereal spread Dane particle - complete virion consisting of a core containing circular DNA formed in liver cell nuclei and a coat which is formed in the cytoplasm and is often found detached from the core. The core antigen is termed HBCAG and the surface antigen, HBsAg. A third antigen e antigen, has three variants and e3 is associated with hepatitis-B-specific DNA polymerase.
- (iii) Hepatitis C - RNA virus related to flaviviridae, long incubation, parenteral spread
- (iv) Hepatitis D - defective RNA virus, infection only occurs if patient has hepatitis B, parenteral spread
- (v) Hepatitis E - RNA virus, short incubation, faecal-oral spread
- (vi) Other hepatitis viruses - unexplained outbreaks of hepatitis and sporadic cases
- (vii) Miscellaneous viral diseases involving the liver include
 - a. Infectious mononucleosis
 - b. Cytomegalovirus
 - c. Herpes hominis
 - d. Yellow fever

Microscopic features

- (i) Necrosis of hepatocytes, usually single-cell but may be zonal
- (ii) Other degenerative changes - 'ballooning'
- (iii) Inflammatory cell infiltration of portal tracts and parenchyma, mainly lymphocytes and macrophages with small numbers of polymorphs

- (iv) Kupffer cell proliferation
- (v) Variable cholestasis
- (vi) Features of regeneration

Variants of acute viral hepatitis

- (i) With bridging necrosis (subacute hepatic necrosis)
- (ii) With massive necrosis
- (iii) 'Cholestatic' hepatitis

Fate of acute viral hepatitis

- (i) Resolution
 - (ii) Massive necrosis and death
 - (iii) Recurrence of acute hepatitis
 - (iv) Chronic persistent hepatitis
 - (v) Chronic active hepatitis (hepatitis B, C and D)
 - (vi) Cirrhosis
2. Bacteria[infection
 - (i) Tuberculosis especially in miliary spread
 - (ii) Brucellosis
 3. Spirochaetes
 - (i) Syphilis
 - a. Congenital pericellular fibrosis
 - b. Gummata - hepar lobatum
 - (ii) Borrelia recurrentis infection
 - (iii) Leptospirosis (Weil's disease)
 4. Protozoa
 - (i) Amoebiasis
 - a. Amoebic hepatitis
 - b. Amoebic abscess
 - (ii) Toxoplasmosis
 5. Rickettsia
 - (i) Q fever
 6. Fungi
 - (i) Histoplasmosis



€ Corpus

The Energy Band

Callosum

Regulator of the Body

The SCIO device can use the Trivector and Cybernetic Loop to rectify aberrant and disharmonious energy patterns in the body. This has profound effects on all body functions but affects the corpus callosum most intensely.

This means that the ability of the conscious verbal mind to relate to the subconscious is increased with the rectification process. The patient will probably not feel the effect. There will always be a positive effect. If there is a negative effect, it is because there is shielded or covert feelings or memories in the subconscious. These will cause disease if left untreated. A simple release may solve the problem.

The changes include:

1. Activate the innate intelligence to balance the body energies. This is the basic principle of chiropractic, acupuncture, and osteopathy medicine.

2. There is an easier exchange of energy and information from right brain to left brain via the corpus callosum. The corpus callosum is the largest energy form in the body and the rectification process has profound effects on stabilizing it, so it dramatically reduces switching phenomena.

3. The SCIO thereby increases the ability of the conscious to interface with the unconscious. This allows greater knowledge of self and of the higher self.

4. There is a greater memory access, a more true access of memory without emotional clouding.

5. There is a greater flexibility of connective tissue, allowing for more resilience.

6. There is a greater oxygenation and hydration ability of the body.

7. There is a smoother muscle control.

8. There is a general increase in well being that the conscious mind is so often unable to perceive. And thus there are thousands of subtle improvements to be found.

7. Parasites
 - (i) Hydatid cysts - Echinococcus granulosus
 - (ii) Opisthorchiasis (Clonorchis)
 - (iii) Fasciola hepatica
 - (iv) Schistosoma mansoni.
 - (v) Ascaris lumbricoides
8. Non-specific inflammation
 - (i) Abscess (pyaemic)
 - (ii) Cholangitis

C. Chronic hepatitis

A diffuse inflammatory condition of the liver in which there are clinical and/or biochemical disturbances for longer than 6 months.

1. Chronic persistent hepatitis

The liver contains excessive numbers of chronic inflammatory cells but these are confined to the portal tracts.

Causes

- (i) Prolonged viral hepatitis
- (ii) Non-specific reaction to systemic disease
- (iii) Inflammatory bowel disease
- (iv) Alpha-I-antitrypsin deficiency

Prognosis

1. Good, the disease usually resolves (unless it is secondary to some untreatable condition), but it may progress to chronic active hepatitis
2. Chronic active hepatitis (CAH)

Excessive numbers of chronic inflammatory cells in portal and peri-portal areas with destruction of liver cells at the interface between connective tissue and parenchyma - piecemeal necrosis.

There might also be:

- (i) Bridging necrosis linking portal tracts
- (ii) Lobular hepatitis - inflammatory infiltration and degenerative changes throughout the parenchyma

Causes

- (i) Primary - ? an auto-immune disease with systemic features
- (ii) Secondary
 - a. Viral

- Hepatitis B
- Hepatitis C
- Hepatitis D
- Neonatal hepatitis
- b. Drugs (see below)
- c. Alcohol (rare)
- d. Wilson's disease
- e. Alpha-1-antitrypsin deficiency

Prognosis

Poor, there is almost invariably progression to cirrhosis but deterioration is delayed by steroid or interferon therapy.

D. Drugs and the liver

Drugs may injure the liver by a direct toxic effect or because of an idiosyncratic reaction where the drug is acting as an allergen. Four major categories of liver damage are produced:

- 1. Direct hepatic necrosis**
- 2. Hepatitis-like reactions**
- 3. Cholestasis and hepatitis**
- 4. Cholestasis alone**

1. Direct hepatic necrosis.

This is usually a predictable injury resulting in zonal or massive necrosis.

Causes include

- (i) Paracetamol (acetaminophen) in acute overdose
- (ii) Ferrous sulphate in acute overdose
- (iii) Carbon tetrachloride and benzene derivatives
- (iv) Methotrexate and 6-mercaptopurine (non-zonal)
- (v) Aflatoxin
- (vi) Tannic acid

2. Hepatitis-like reactions. These are hypersensitivity reactions and may produce a histological picture indistinguishable from acute viral hepatitis or a chronic active hepatitis.

Causes include

- (i) Halothane
- (ii) Monoamine oxidase inhibitors

- (iii) (a-Methyldopa
- (iv) Isoniazid
- (v) Oxyphenisatin
- (vi) Nitrofurantoin
- (vii) Sulphonamides

3. Cholestasis and hepatitis. This also represents a hypersensitivity reaction in which cholestasis is the major feature but some histological evidence of hepatitis is usually present.

Causes include

- (i) Phenothiazines especially chlorpromazine
- (ii) Tricyclic antidepressants
- (iii) Anxiolytic drugs (chlordiazepoxide, diazepam)
- (iv) Anti-inflammatory drugs (phenylbutazone, indomethacin)
- (v) Anti-tuberculous drugs (PAS, rifampicin)
- (vi) Antibiotics (erythromycin, sulphamethoxazole)
4. Cholestasis alone

This injury is not related to hypersensitivity but genetic factors may alter susceptibility:

Causes

- (i) Anabolic steroids (methyltestosterone/norethandrolone)
- (ii) Contraceptive steroids
5. Miscellaneous drug injuries
 - (i) Diffuse fatty liver - tetracycline
 - (ii) Increase in liver cell lipofuscins - phenacetin
 - (iii) Fatty change, fibrosis, and cirrhosis - long-term methotrexate therapy for psoriasis
 - (iv) Central vein occlusion - Senecio alkaloids, urethane
 - (v) Peliosis hepatitis (haemorrhagic cysts) - anabolic steroids
 - (vi) Granulomata - phenylbutazone
6. Alcohol and the liver
 - (i) Fatty liver - may be associated with:
 - a. Jaundice
 - b. Portal hypertension
 - c. Encephalopathy
 - d. Fat embolism (very rare)
 - (ii) Alcoholic hepatitis

Features

- a. Centrilobular single-cell necrosis
- b. Mallory's hyaline bodies
- c. Fatty change
- d. Polymorph infiltration
- e. Pericellular collagenisation
- f. Perivenular fibrosis
- g. Giant mitochondria
- (iii) Cirrhosis
- (iv) Portal fibrosis
- (v) Chronic active hepatitis
- (vi) Cholestasis (unusual)
- E. Degenerative/metabolic disorders**
- 1. Brown atrophy - lipofuscinosis
- 2. Fatty change
 - (i) Diabetes mellitus
 - (ii) Starvation
 - (iii) Alcoholic
 - (iv) Obesity
 - (v) Kwashiorkor
 - (vi) Drugs - methotrexate, corticosteroids
 - (vii) Reye's syndrome (? viral aetiology, usually preceded by influenza or varicella infection, associated with salicylates)
 - a. Fever/vomiting
 - b. Hypoglycaemia
 - c. Respiratory acidosis
 - d. Encephalopathy
 - e. Liver shows microvesicular fatty change
- 3. Amyloidosis - usually secondary type
- 4. Glycogen deposition
 - (i) Diabetes mellitus (with nuclear vacuolation)
 - (ii) Von Gierke's disease
- 5. Lipid storage

- (i) Hand-Schüller-Christian disease
- (ii) Gaucher's disease
- (iii) Niemann-Pick
- 6. Haemosiderosis/haemochromatosis
- 7. Wilson's disease
- F. Vascular disorders**
- 1. Portal hypertension follows obstruction to the portal blood flow somewhere along its course
 - (i) Extrahepatic portal vein
 - a. Thrombosis possibly secondary to pancreatitis or pylephlebitis
 - b. Pressure from glands in porta hepatis
 - c. Invasion by carcinoma of pancreas or biliary tract
 - d. Stricture or ligature following surgery
 - (ii) Intrahepatic portal veins
 - a. Schistosomiasis
 - b. Infiltration of portal tracts by lymphoma, myeloproliferative disease, or sarcoidosis
 - c. Congenital hepatic fibrosis
 - d. Obliterative portal venopathy
 - (iii) Sinusoids or small hepatic veins
 - a. Cirrhosis
 - b. Veno-occlusive disease resulting from ingestion of Senecio alkaloids, administration of cytotoxic drugs and liver irradiation
 - (iv) Hepatic veins (Budd-Chiari syndrome)
 - a. Thrombosis
 - b. Tumour involvement
 - (v) Chronic venous congestion of liver (CVC)
 - a. Congestive cardiac failure
 - b. Constrictive pericarditis
 - c. Tricuspid incompetence
- 2. Infarcts resulting from occlusion of the hepatic arteries are uncommon and usually result from a severe arteritis or when the additional supply from the portal vein is diminished. Occlusion of intrahepatic branches of the portal vein results in haemorrhagic lesions - 'Zahn's infarcts'.
- 3. Hypoxic centrilobular necrosis is seen in shock.

4. Cardiac 'cirrhosis'

Prolonged and severe CVC leads to centrilobular necrosis, distortion of reticulin framework and scarring. In the most severe cases this scarring may link up adjacent central veins to produce 'reverse lobulation'. The intervening parenchyma rarely shows sufficient evidence of regeneration to justify the term cirrhosis.

G. Bile duct diseases

1. Primary biliary cirrhosis

- (i) Granulomatous inflammation around medium sized bile ducts
- (ii) Destruction and disappearance of ducts
- (iii) Aggregated lymphocytic infiltration
- (iv) Lipid-laden macrophages in portal tracts
- (v) Anti-mitochondrial antibodies in serum

2. Sclerosing cholangitis

- (i) Loss of bile ducts in liver
- (ii) Fibrous obliteration of extra-hepatic biliary system
- (iii) Association with ulcerative colitis
- (iv) Proceeds to biliary cirrhosis (secondary)

H. Cirrhosis

A combination of widespread fibrosis and regenerative nodule formation following necrosis of liver cells.

Aetiological classification

1. Cryptogenic or idiopathic
2. Toxic or drug-induced
 - (i) Alcohol
 - (ii) Methotrexate
 - (iii) Aflatoxins
3. Viral hepatitis (including neonatal hepatitis)
4. Immunologically mediated
 - (i) Chronic active hepatitis
 - (ii) Primary biliary cirrhosis
5. Secondary biliary cirrhosis, resulting from long standing obstruction
6. Metabolic and inherited disorders
 - (i) Haemochromatosis
 - (ii) Wilson's disease

- (iii) α_1 -antitrypsin deficiency
 - (iv) Cystic fibrosis
 - (v) Hereditary haemorrhagic telangiectasia
 - (vi) Galactosaemia
 - (vii) Hereditary fructose intolerance
7. Intestinal by-pass
 8. Indian childhood cirrhosis

Incidence

1. Alcoholic (about 60%)
2. Viral (10%)
3. Biliary (10%)
4. Disordered iron metabolism (5%)
5. Other metabolic disorders (1%)
6. Idiopathic (15%)

Complications of cirrhosis

1. Hepatocellular failure
 - (i) Increasing jaundice
 - (ii) Coagulopathy - decreased synthesis of factors V, VII, IX and X
 - (iii) Encephalopathy
 - (iv) Hyperoestrogenism
2. Portal hypertension
 - (i) Splenomegaly
 - (ii) Enlargement of porto-systemic anastomoses
 - (iii) Ascites
3. Intercurrent infection, e.g. suppurative peritonitis
4. Development of liver-cell carcinoma

I. Tumour-like lesions

1. Cavernous haemangioma
2. Mesenchymal hamartoma
3. Focal nodular hyperplasia
4. Diffuse nodular hyperplasia
5. Partial nodular transformation

J. Benign tumours

1. Adenoma
 - (i) Bile duct adenoma
 - (ii) Liver cell adenoma (associated with contraceptive steroids)
2. Infantile haemangioendothelioma

K. Malignant tumours

1. Liver cell carcinoma predisposing factors
 - (i) Cirrhosis, especially haemochromatosis
 - (ii) Aflatoxins?
 - (iii) Hepatitis B infection
2. Bile duct carcinoma Predisposing factors
 - (i) Clonorchis sinensis infestation
 - (ii) Arsenic
 - (iii) Ulcerative colitis
3. Haemangiosarcoma Predisposing factors
 - (i) Polyvinyl chloride manufacture
 - (ii) Thorotrast
4. Hepatoblastoma
5. Lymphoma
6. Fibrosarcoma/neurogenic sarcoma (very rare)
7. Metastatic carcinoma is very common. The main sources are:
 - (i) Gastrointestinal tract
 - (ii) Breast
 - (iii) Bronchus

Likewise involvement by leukaemias and lymphomas arising elsewhere is common

L. Hyperbilirubinaemia (jaundice)

Causes of jaundice:

1. Excessive bilirubin production capacity of the liver
 - (i) Haemolysis due to
 - a. Hereditary spherocytosis
 - b. Hereditary red-cell enzyme defects
 - c. Thalassaemia

- d. Sickle-cell disease
- e. Auto-immune haemolytic anaemia
- f. Secondary to Hodgkin's disease, leukaemias, etc.
 - (ii) Increased production by the bone marrow – primary 'shunt' hyperbilirubinaemia
2. Decreased uptake of bilirubin into liver cells and transport to the smooth endoplasmic reticulum
 - (i) Gilbert's disease. A familial condition resulting in mild intermittent jaundice
 - (ii) Viral hepatitis
3. Defective conjugation of bilirubin
 - (i) Glucuronyl transferase deficiency
 - a. Neonatal jaundice ('physiological')
 - b. Crigler-Najjar disease. A very rare condition giving rise to severe persistent jaundice and deposition of bilirubin in the brain - kernicterus
 - (ii) Glucuronyl transferase inhibitor in the maternal serum familial neonatal hyperbilirubinaemia (Lucey-Driscoll syndrome)
4. Disturbances of bilirubin excretion

Intrahepatic:

- (i) Impaired cellular excretion into canaliculi
 - a. Viral hepatitis (cholestatic type)
 - b. Alcoholic hepatitis
 - c. Dubin-Johnson syndrome, associated with marked lipofuscin deposition in liver cells
 - d. Rotor syndrome, without such pigment
- (ii) Canalicular or ductular obstruction
 - a. Drug hypersensitivity, e.g. chlorpromazine
 - b. C-17 substituted steroids such as methyl testosterone
 - c. Cholestatic jaundice of pregnancy and the pill
 - d. Breast-milk jaundice of neonates
 - e. Associated with Hodgkin's disease and other lymphomas
 - f. Severe infections
 - g. Idiopathic recurrent cholestasis
- (iii) Bile duct obstruction
 - a. Primary biliary cirrhosis
 - b. Sclerosing cholangitis

- c. Intrahepatic biliary atresia
- d. Cholangiocarcinoma

Extrahepatic bile duct obstruction

- (i) Gall stones
 - (ii) Carcinoma of the pancreas/ampulla
 - (iii) Pressure by tumour involved lymph glands at the porta hepatis
 - (iv) Sclerosis of the extrahepatic ducts
 - (v) Postoperative stricture
 - (vi) Extrahepatic atresia
5. Hepatic failure

The jaundice of hepatic failure may result from several disturbances but the principal defect is that there are insufficient functioning liver cells to conjugate the normal bilirubin load. The major causes are:

- (i) Terminal cirrhosis
- (ii) Massive necrosis
 - a. Fulminant viral hepatitis
 - b. Drug hepatotoxicity, e.g. paracetamol (acetaminophen) overdose, halothane hepatitis

DISEASES OF THE GALL-BLADDER AND EXTRA-HEPATIC BILE DUCTS

A. Congenital

- 1. Atresia of the gall-bladder or of any part of the hepatic or common bile ducts
- 2. Folded gall-bladder
- 3. Complete or incomplete septum across the lumen
- 4. 'Floating' gall-bladder
- 5. Anomalies of the Cystic duct and artery
- 6. Choledocal cyst

B. Inflammation

- 1. Acute cholecystitis Results
 - (i) Resolution
 - (ii) Empyema
 - (iii) Gangrene which may perforate and produce
 - a. Generalised peritonitis
 - b. Local abscess
 - (iv) Ascending cholangitis

- 2. Chronic cholecystitis Features
 - (i) Fibrosis
 - (ii) Mucosal herniations (Aschoff-Rokitansky sinuses)
 - (iii) Chronic inflammatory cell infiltrate
 - (iv) Muscular hypertrophy

C. Cholelithiasis

Factors involved

- (i) Production of abnormal bile
 - a. Excess bile pigment
 - b. Excess of cholesterol relative to bile salts and lecithin
- (ii) Infection and inflammation
- (iii) Stasis

Composition

- (i) Mixed stones (about 90%)
- (ii) Pure stones
 - a. Cholesterol
 - b. Calcium bilirubinate
 - c. Calcium carbonate

Effects

- (i) Clinically 'silent'
- (ii) Inflammation - provoke acute and chronic cholecystitis
- (iii) Obstruction
 - a. Cystic duct; leading to empyema and mucocoele
 - b. Common bile duct; producing obstructive jaundice
 - c. Ampulla of Vater; jaundice and in some cases acute pancreatitis
- (iv) Erosion and perforation
 - a. Biliary peritonitis
 - b. Gall-stone ileus
- (v) Malignant change

Gall-stones are present in about 90% of cases of carcinoma of the gall-bladder

Risk factors

- (i) Obesity

- (ii) Diet
- (iii) Race
- (iv) Sex
- (v) Reduced entero-hepatic circulation

D. Mechanical disorders

1. Diverticulosis of the gall-bladder

- (i) Fundal, usually in relation to a congenital septum (socalled 'adenomyoma')
- (ii) Generalised - 'cholecystitis glandularis proliferans'

2. Obstruction to the extra-hepatic bile ducts

- (i) Gall stones
- (ii) Benign stricture
 - a. Following surgery
 - b. Traumatic
 - c. Fibrosis around a peptic ulcer
 - d. Chronic pancreatitis
 - e. Benign bile duct tumours
 - f. Sclerosing cholangitis
- (iii) External pressure
 - a. Carcinoma of the pancreas
 - b. Enlarged lymph glands at the porta hepatis
 - c. Duodenal diverticulum
- (iv) Malignant stricture/occlusion
 - a. Carcinoma of the Ampulla
 - b. Carcinoma of the bile ducts
 - c. Invasion by neighbouring carcinoma
- (v) Atresia

E. Benign tumours

- 1. Papilloma
- 2. Adenoma
- 3. Papillary adenomatosis (widespread)

F. Malignant tumours

Carcinoma

- (i) Gall-bladder
 - a. Papillary
 - b. Diffuse infiltration

Microscopic appearances

- a. Adenocarcinoma
- b. Squamous carcinoma (metaplasia)
- c. Anaplastic
- (ii) Extra-hepatic ducts Gross features
 - a. Papillary nodule
 - b. Thickening of the wall

Microscopical appearances

- a. Papillary adenocarcinoma
- b. Scirrhous, mucus-secreting adenocarcinoma

G. Stricture of the bile ducts

- 1. Congenital biliary atresia
- 2. Surgery and post-traumatic
- 3. Post-inflammatory
 - (i) Gall-stones
 - (ii) Local inflammation - duodenal ulcer or pancreatitis
 - (iii) Parasites
- 4. Tumours
 - (i) Adenoma
 - (ii) Adenocarcinoma
 - (iii) Extrinsic lymph node involvement

DISEASES OF THE PANCREAS

A. Congenital

- 1. Aplasia and hypoplasia
- 2. Ectopic pancreas in
 - (i) Stomach and duodenum
 - (ii) Jejunum

- (iii) Meckel's diverticulum
- (iv) Ileum
- 3. Anomalies of the ducts
- 4. Annular pancreas
- 5. Mucoviscidosis (cystic fibrosis)

Lesions mainly due to exocrine gland obstruction by secretions. Pathogenesis unknown.

Autosomal recessive inheritance

Lesions

- (i) Meconium ileus
- (ii) Pancreas - fibrocystic changes
- (iii) Lungs - recurrent bronchopneumonia usually staphylococcal
- (iv) Liver - biliary cirrhosis
- (v) Salivary glands - acinar atrophy and fibrosis
- 6. Congenital cysts

B. Inflammations

1. Acute haemorrhagic pancreatitis Aetiological factors

- (i) Alcohol excess-causes hypersecretion and protein-plugging
- (ii) Bile reflux - biliary tract disease and gall-stones
- (iii) Ischaemia
- (iv) Reflux of duodenal juice

A small proportion of cases are associated with:

- (i) Hypothermia in the aged
- (ii) Mumps
- (iii) Primary hyperparathyroidism
- (iv) Hyperlipoproteinaemia
- (v) Pregnancy and gall-stones
- (vi) Trauma
- (vii) Carcinoma of the pancreas
- (viii) Corticosteroid and azathioprine therapy

Effects (in severe cases)

- (i) Hypovolaemic shock
- (ii) Paralytic ileus

- (iii) Hypocalcaemia (tetany)
- (iv) Hypomagnesaemia

Results

- (i) Resolution, usually incomplete
- (ii) Abscess
- (iii) Pseudocyst formation in lesser-sac
- (iv) Recurrent acute pancreatitis
- (v) Chronic pancreatitis
- 2. Chronic pancreatitis

Aetiology

- (i) Idiopathic
- (ii) Alcohol excess
- (iii) Following acute pancreatitis
- (iv) Biliary tract disease
- (v) Haemochromatosis

Effects

- (i) Exocrine insufficiency – steatorrhoea
- (ii) Diabetes mellitus
- (iii) Obstructive jaundice
- (iv) Haematemesis and melaena

C. Degenerative disorders

- 1. Fatty infiltration (adiposity)
- 2. Atrophy
 - (i) Atherosclerotic
 - (ii) Obstruction of major ducts resulting from
 - a. Atresia or congenital stenosis
 - b. Pancreatic calculi
 - c. Squamous metaplasia
 - d. Carcinoma involving ducts
 - e. Ligature
 - f. Inflammatory stenosis
- 3. Acinar ectasia in uraemia

D. Benign tumours

1. Cystadenoma - microglandular, glycogen-rich type
2. Fibroma
3. Lipoma
4. Haemangioma

E. Carcinoma of the pancreas

Microscopic types

1. Adenocarcinoma
 - (i) Mucus-secreting (mucinous cystadenocarcinoma)
 - (ii) Acinar, non-mucus secreting
2. Anaplastic (uncommon)
3. Solid and cystic tumour

Complications

1. Biliary obstruction
 - (i) Obstructive jaundice
 - (ii) Cholangitis
 - (iii) Biliary cirrhosis
2. Invasion of duodenum - bleeding
3. Diabetes mellitus
4. Venous thrombosis
 - (i) Portal vein
 - (ii) Thrombophlebitis migrans
5. Acute and chronic pancreatitis
6. Excessive lipase secretion by widespread tumour may give
 - (i) Polyarthrititis
 - (ii) Panniculitis (fat necrosis)
 - (iii) Eosinophilia
7. Myopathy/peripheral neuropathy
8. Thrombotic endocarditis
9. Fibrinolysis and haemorrhage

Islet cell tumours

1. Insulinoma (B-cell tumour)

Usually solitary but in about 10% of cases are multiple. 10-15% are malignant

2. Gastrinoma (delta-cell tumour) associated with the Zollinger-Ellison syndrome

About 60% are malignant

3. Glucagonoma

21. Cardiovascular system

PERICARDIUM

A. Inflammation

1. Acute pericarditis

- (i) Secondary to myocardial infarction
- (ii) Uraemia
- (iii) Rheumatic fever
- (iv) Infectious causes
 - a. Bacterial - staphylococcal, pneumococcal
 - b. Viral - especially Coxsackie B
- (v) Drug reactions
- (vi) Postmyocardial infarction/postcardiotomy syndromes
- (vii) Idiopathic

2. Chronic pericarditis

- (i) Tuberculosis
- (ii) Rheumatoid disease
- (iii) SLE
- (iv) Systemic sclerosis
- (v) Idiopathic constrictive pericarditis
- (vi) Actinomycosis
- (vii) Amoebiasis

B. Tumours of the pericardium

1. Secondary involvement by:

- (i) Carcinoma
 - a. Bronchus
 - b. Oesophagus
 - c. Breast
- (ii) Lymphoma/leukaemia

- (iii) Thymoma
- 2. Mesothelioma

HEART

A. Congenital

1. Disorders of the entire heart

- (i) Dextrocardia - with or without Situs inversus
- (ii) Laevocardia
- (iii) Cardiomegaly Causes
 - a. Shunts
 - b. Anomalies of the coronary arteries
 - c. Myocarditis
 - d. Infantile endocardial fibroelastosis
 - e. Hereditary diseases - Friedreich's ataxia, Refsum's syndrome
 - f. Storage disorders - Glycogen storage (Pompe's disease)
- (iv) Congenital 'rhabdomyomas', as in tuberous sclerosis

2. Acyanotic shunts (left-right)

- (i) Ventricular septal defect (VSD)
- (ii) Atrial septal defect (ASD)
- (iii) Patent ductus arteriosus

3. Cyanotic shunts (right-left)

- (i) Tetralogy of Fallot
 - a. Pulmonary stenosis
 - b. Ventricular septal defect
 - c. Dextraposition and over-riding of the aorta
 - d. Right ventricular hypertrophy
 - (ii) Eisenmenger complex
VSD with reversal of shunt resulting from pulmonary hypertension
 - (iii) Transposition of the great vessels
- #### 4. Valvular abnormalities
- (i) Additional cusps
 - a. Aortic
 - b. Pulmonary

- (ii) Missing cusps
 - a. Bicuspid aortic
 - b. Bicuspid pulmonary
- (iii) Malpositioning
 - a. Ebstein's anomaly - malformation of the tricuspid with downward displacement
- (iv) Atresia
 - a. Aortic
 - b. Pulmonary (+VSD)
 - c. Tricuspid (+ASD)
 - d. Mitral (+ASD)
- (v) Stenosis
 - a. Aortic
 - b. Pulmonary - isolated or associated with other defects in Fallot's tetralogy
- (vi) 'Floppy' valve - deposition of proteoglycans in the mitral valve sometimes associated with Marfan's syndrome

Effects of congenital heart disease

1. Shunting - initially left to right but with the development of pulmonary hypertension the shunt is reversed and cyanosis appears
2. Overloading of the right ventricle leading to hypertrophy and failure
3. Pulmonary hypertension
4. Infective endocarditis
5. Secondary polycythaemia
6. Conduction disturbances
7. General predisposition to infection

B. Myocarditis

Inflammation of the myocardium caused by:

1. Rheumatic fever
2. Viral diseases

Coxsackie B

- (ii) Echo virus
- (iii) Poliomyelitis
- (iv) Mumps
- (v) Measles

SPORT history

**pictures on China, AC Milan,
San Antonio spurs, Dennis Johnson**

The first sport study with the Quantum Xrroid technology was on members of the Cleveland Browns football team in 1988. The results were amazing and all of the participants went all Pro over the next five years. Having worked with the power lifting team of Hungary in 1991 they went from moderate to gold medal performance.

AC Milan bought some systems and their injury level dropped 91%. This was because the system can stimulate and accelerate healing of injured tissue. They asked for us to develop the device to sharpen the athletic skills of the clients. With this in mind we developed a way to sharpen coordination endurance and strength. AC Milan won the European championship the next two years. We worked with Dennis Johnson ex twice NBA MVP in the San Antonio Spurs system. The results were amazing.

The Chinese Olympic team had us do a study. Out of their 487 athletes in the 2008 Olympic Games, they assigned 150 of the sick, old, weak, and tired to us. The study was to see if we could repair injured tissue and get an athlete back onto the field. The results were astounding. Out of the hundred medals won by the Chinese our 30% of the injured performers won 33 % of the medals. Our athletes were not supposed to win. And because of this 'Desire' was awarded an honorary Gold medal.

Sports medicine has entered the energetic arena. There are those who want to win and they differ from those who want to conform.

**Some of the best cyclists in the world
have used the SCIO to win championships**



First Sport Study was with the Cleveland Browns 1988



The AC Milan team thanked Prof Nelson for helping them win the Italian and European Championship



- (vi) Infectious mononucleosis
- (vii) Variola

3. Bacterial infections
 - (i) Diphtheria
 - (ii) Typhoid
 - (iii) Spread from pericarditis, infective endocarditis
 - (iv) Pyaemic spread, staphylococci, streptococci, etc.
4. Parasitic diseases
 - (i) Toxoplasmosis
 - (ii) Trichinosis
 - (iii) Trypanosomiasis (Chagas' disease)
5. Acute idiopathic myocarditis (Fiedler's)
 - (i) Diffuse interstitial form
 - (ii) Giant-cell (tuberculoid) form

6. Sarcoidosis
7. Syphilis

C. Cardiomyopathy

Definition
'Diffuse myocardial disease not attributable to ischaemia, or pressure or volume overload'

- Types
1. Dilated
 2. Hypertrophic
 3. Restrictive, including obliterative

- Causes
1. Dilated
 - (i) Systemic disorders Some cases of:
 - a. Amyloidosis
 - b. Sarcoidosis
 - c. Haemochromatosis
 - (ii) Toxicity
 - a. Alcohol
 - b. Cobalt



- c. Lithium
- d. Nickel
- e. Anthracyclins
 - Adriamycin
 - Daunorubicin
 - Cyclophosphamide
- (iii) Nutritional deficiencies
 - a. Beri-beri
 - b. Chronic alcoholism
 - c. ? Post-partum
- (iv) Post-infection
 - a. Viral myocarditis Coxsackie Herpes simplex
 - b. Chagas' disease
- (v) Idiopathic
- 2. Hypertrophic
 - (i) Inherited - as an autosomal dominant
 - (ii) Idiopathic
- 3. Restrictive
 - (i) Idiopathic diffuse myocardial fibrosis
 - (ii) Endocardial fibro-elastosis
 - (iii) Endomyocardial fibrosis (obliterative)
 - (iv) Some cases of:
 - a. Amyloidosis
 - b. Sarcoidosis
 - c. Haemochromatosis

D. Rheumatic fever

Aetiology

An allergic reaction to streptococcal antigens

1. ? Antibodies to these antigens cross-react with myocardial fibres, arterial smooth muscle cells, and connective tissue proteoglycans
2. ?? Immune complexes are formed which are deposited at the site of the lesions.

The Aschoff nodule

1. Fibrinoid degeneration of collagen

2. Mixed inflammatory cells
3. Large mesenchymal cells (Anitschkow myocytes) which are probably altered fibroblasts
4. Occasional Aschoff giant-cells

Lesions

1. Heart
 - (i) Pericarditis - 'bread and butter' type
 - (ii) Myocarditis
 - (iii) Endocarditis

Valvulitis with vegetations

- a. Mitral
- b. Aortic
- c. Pulmonary (uncommon)
- d. Tricuspid (rare)
- (iv) Chronic deformity
 - a. Mitral stenosis/incompetence
 - b. Aortic stenosis/incompetence

- (v) Atrial fibrillation
2. Joints
 - Synovitis and inflammation of the capsule
3. Brain
 - (i) Sydenham's chorea
 - (ii) Acute meningo-encephalitis
4. Skin
 - (i) Subcutaneous nodules
 - (ii) Erythema nodosum
 - (iii) Erythema marginatum
 - (iv) Erythema multiforme
 - (v) Petechiae
 - (vi) Urticaria
 - (vii) Livedo reticularis
5. Lungs
 - Acute pneumonitis

6. Arteries
Acute fibrinoid arteritis affecting coronary, cerebral, renal and mesenteric vessels

E. Infective endocarditis

Causes

1. Streptococcus viridans
2. Staphylococci
3. Enterococci (Streptococcus faceless)
4. Brucelia
5. Haemophilus group
6. Coxiella burneti
7. Candida albicans
8. Histoplasma capsulatum
9. Aspergillus fumigatus
10. Cryptococcus neoformans

Predisposing lesions

1. Valves previously damaged by rheumatic fever
2. Congenital valvular abnormalities, e.g. bicuspid aortic valve
3. Interstitial valvulitis due to stress, hypersensitivity reactions, exposure to cold or high altitudes
4. Valvular endocarditis resulting from virus infections

Mechanism

1. Development of bland, fibrin-platelet thrombi on distorted or inflamed myocardium
2. Seeding of these small vegetations by organisms from the blood stream
3. Further fibrin deposition and proliferation of organisms give rise to larger, friable vegetations characteristic of infective endocarditis

Lesions of infective endocarditis

1. Features of infection and toxæmia
 - (i) Weight loss
 - (ii) Anaemia
 - (iii) Cafe au lait skin pigmentation
 - (iv) Splenomegaly
2. Embolic features
 - (i) Infarcts - brain, kidney, spleen

- (ii) Splinter haemorrhages
 - (iii) Metastatic abscesses
 - (iv) Mycotic aneurysms
3. Immune-complex deposition
 - (i) Kidney lesions
 - a. Focal glomerulonephritis ('embolic nephritis')
 - b. Diffuse proliferative glomerulonephritis
 - (ii) Brain
 - a. Focal encephalitis
 - b. Cerebral arteritis
 - (iii) 'Microembolic lesions'
 - a. Petechial rash
 - b. Osier's nodes
 - c. Roth's spots in the retina
 - d. Retinal haemorrhage
 - e. Nodular haemorrhagic lesions on palms and soles

Causes of death

1. Acute valve perforation
2. Embolism
3. Ruptured mycotic aneurysm
4. Renal failure - diffuse glomerulonephritis

F Ischaemic heart disease

Aetiology

1. Coronary atherosclerosis alone or complicated by
 - (i) Thrombosis
 - (ii) Haemorrhage into a plaque
 - (iii) Rupture of a plaque
2. Narrowing of the coronary ostia due to
 - (i) Atherosclerosis of the aorta or rarely,
 - (ii) Syphilitic aortitis
 - (iii) Dissecting aneurysms
3. Coronary arteritis

4. Embolism
5. Trauma
6. Thrombotic haematological diseases
7. Congenital abnormalities of the arteries
8. Irradiation

Types

1. Chronic ischaemic fibrosis
2. Infarction
 - (i) Subendocardial
 - (ii) Transmural

Sequence of events

- | | |
|----------------------|--|
| 6-12 h | fibres show degenerative changes |
| (i) | Increased eosinophilia |
| (ii) | Swelling |
| 12 h | polymorphs appear |
| 18-24 h | area paler than normal |
| 48 h | area outlined by a hyperaemic border, fibres become coagulated, and nuclear pyknosis increases |
| 4-10 days increasing | muscle becomes yellow and necrotic (myomalacia cordis) and there is granulation tissue formation |
| 12 days | collagen appears |
| 3 weeks | infarct totally replaced by granulation tissue |
| 3 months | shrunken scar |

Complications

1. Conduction defects and rhythm disturbances
2. Fibrinous or haemorrhagic pericarditis
3. Mural thrombosis and embolism
4. Rupture giving rise to:
 - (i) Massive haemorrhage into the pericardium (cardiac tamponade)
 - (ii) Breach in the septum resulting in acute cardiac failure
5. Cardiac aneurysm

6. Cardiac failure

H. Tumours

1. Benign (rare)
 - (i) Atrial myxoma
 - (ii) Congenital rhabdomyoma (hamartoma)
2. Malignant (all very rare)
 - (i) Undifferentiated spindle-cell sarcoma
 - (ii) Rhabdomyosarcoma
 - (iii) Fibrosarcoma
 - (iv) Secondary tumours

BLOOD VESSELS

A. Arteriosclerosis and atherosclerosis

B. Vasculitis

Features

1. Swelling, separation or necrosis of endothelial cells
2. Intimal thickening
3. Leucocyte infiltration of the wall
 - (i) Acute
 - a. Neutrophilic vasculitis
 - b. Eosinophilic (allergic) vasculitis
 - (ii) Chronic
 - a. Lymphocytic
 - b. Granulomatous
4. Destruction of the elastica and media
5. Superimposed thrombosis

Causes

1. Immune mechanisms
 - (i) immune complex deposition
 - (ii) Cell-mediated damage
2. Infections
 - (i) Acute pyogenic infections by
 - a. Direct extension

- b. Infected thromboemboli
- (ii) Chronic
 - a. Syphilis
 - b. Tuberculosis
- 3. Chemical agents
 - (i) Endogenous
 - a. Gastric acid
 - b. Bile
 - (ii) Exogenous
 - a. Sclerosing agents
 - b. Caustic or irritant chemicals
- 4. Physical agents
 - (i) Trauma
 - a. Vibrating tools
 - b. Intravascular catheters
 - c. Pacemaker leads
 - Ionizing radiation

Vasculitis syndromes

- 1. Connective tissue diseases
 - (i) Rheumatic fever
 - (ii) Rheumatoid disease
 - (iii) Ankylosing spondylitis
 - (iv) SLE
 - (v) Polyarteritis nodosa
- 2. Wegener's granulomatosis Features
 - (i) Ischaemic necrosis in
 - (ii) Facial ulceration
 - (iii) Glomerulonephritis
- 3. Thromboangiitis obliterans Features
 - (i) Segmental involvement of medium and small arteries often involving the adjacent vein
 - (ii) Superimposed thrombosis with recanalisation and fibrosis
 - (iii) Leads to progressive ischaemia of the extremities and ultimately to gangrene

- 4. Takayasu's disease (syn. pulseless disease) Features
 - (i) Fibrous thickening of the intima
 - (ii) Chronic inflammation of the media
 - (iii) Adventitial fibrosis

Primarily affects the arch of the aorta and the proximal branches
- 5. Giant-cell arteritis Features
 - (i) Systemic arteritis dominated by temporal artery involvement upper and lower respiratory tract
 - (ii) Disruption of the elastica with giant cell formation
 - (iii) Association with polymyalgia rheumatica
- 6. 'Allergic' vasculitis
 - (i) Visceral
 - a. Appendix
 - b. Gall-bladder
 - c. Breast
 - d. Urinary bladder
 - (ii) Skin
 - a. Erythema nodosum
 - b. Erythema induratum
 - c. Drug reactions
 - d. Weber-Christian disease
 - e. Nodular vasculitis
 - (iii) Allergic granulomatosis
 - a. Asthma and pulmonary vasculitis
 - b. Blood eosinophilia
 - c. Elevated IgE levels
- 7. Serum or drug-induced vasculitis
- 8. Post-infection vasculitis Causes
 - (i) Infective endocarditis
 - (ii) Infected shunts
 - (iii) Leprosy
 - (iv) Malaria

Features

- (i) Fever and skin rash
- (ii) Arthritis
- (iii) Focal segmental glomerulonephritis
- 9. Kawasaki's disease syndrome (syn. mucocutaneous lymph node)

Features

- (i) Fever and erythematous rash
- (ii) Oedema and congestion of conjunctivae and mucous membranes
- (iii) Non-suppurative cervical lymphadenopathy

22. Respiratory system

NOSE AND NASAL SINUSES

A. Congenital

- 1. Choanal stenosis or atresia
- 2. Involvement in cleft palate
- 3. Saddle nose in hypertelorism

B. Inflammation

- 1. Acute rhinitis
 - (i) Common cold
 - (ii) Allergic
 - (iii) Measles
 - (iv) Irritant fumes
 - (v) Diphtheria
- 2. Acute sinusitis - non-specific, bacterial
- 3. Chronic hypertrophic rhinitis
- 4. Chronic atrophic rhinitis
 - (i) Simple atrophy
 - (ii) Ozaena caused by Klebsiella infection
- 5. Chronic specific infections of the nose
 - (i) Tuberculosis
 - (ii) Leprosy
 - (iii) Syphilis
 - (iv) Rhinoscleroma

- (v) Fungal infections
 - a. Candidacies
 - b. Aspergillosis
 - c. Phycomycosis
 - d. Rhinosporidiosis
 - e. S. American blastomycosis
- (vi) Leishmaniasis

6. Wegener's granulomatosis

C. Nasal polyps

- 1. Allergic
 - (i) Allergic rhinitis
 - (ii) Vasomotor rhinitis
- 2. Non-allergic including antro-choanal polyps

D. Tumours of the nose and naso-pharynx

- 1. Epithelial
 - (i) Squamous papilloma
 - (ii) Transitional-type ('inverted') papilloma
 - (iii) Keratoacanthoma
 - (iv) Adenoma arising from mucous glands
 - (v) Carcinoma
 - a. Squamous
 - b. Transitional-type
 - c. Adenocarcinoma
 - d. Anaplastic including 'lymphoepithelioma'
 - (vi) Malignant melanoma
- 2. Vascular
 - (i) Capillary haemangioma
 - (ii) Juvenile angiofibroma
 - (iii) Haemangiopericytoma
 - (iv) Haemangioendothelioma (angiosarcoma)
- 3. Lymphoid tissue
 - (i) Lymphoma

- (ii) Malignant histiocytosis
- (iii) Myeloma
- 4. Neurogenic
 - (i) Neurilemmoma
 - (ii) Neurofibroma
 - (iii) Nasal 'glioma' (ectopic glial tissue)
 - (iv) Olfactory neuroblastoma
- 5. Bone and connective tissues
 - (i) Osteoma
 - (ii) Chondroma
 - (iii) Ossifying fibroma
 - (iv) Fibrosarcoma
 - (v) Chondrosarcoma
 - (vi) Osteogenic sarcoma
 - (vii) Chordoma

LARYNX

A. Congenital

1. Laryngeal web
2. Stenosis
3. Laryngocele

B. Inflammation

1. Acute laryngitis (bacterial and viral)
2. Acute epiglottitis (Haemophilus influenzae type B)
3. Chronic laryngitis
 - (i) Non-specific
 - (ii) Tuberculosis
 - (iii) Syphilis
 - (iv) Fungal infections
 - (v) Scleroma
 - (vi) Leprosy

C. Polyps, cysts and benign tumours

1. Vocal cord polyps and nodules (Singer's nodes)

2. Cysts

- (i) Mucus retention cysts
 - (ii) Epidermoid cysts
 - (iii) Branchial cysts
- ## 3. Benign tumours
- (i) Juvenile papillomatosis
 - (ii) Adult papilloma
 - (iii) Adenoma of sero-mucinous glands
 - (iv) Papillary cystadenoma
 - (v) Chondroma
 - (vi) Neurogenic tumours
 - (vii) Lipoma
 - (viii) Granular cell myoblastoma
 - (ix) Amyloid 'tumour'

D. Pre-malignant and malignant lesions

1. 'Keratinosis'

Keratinisation and epithelial hyperplasia with or without dysplasia (laryngeal intra-epithelial neoplasia I and II)

2. Carcinoma-in-situ / LIN III
3. Invasive carcinoma

Sites

- (i) Supraglottic

Glottic - vocal cords and the commissures. This is the most frequent site and carries the best prognosis

- (iii) Subglottic
- (iv) Transglottic - extensive tumours with a poor prognosis

Microscopic appearances

- (i) Squamous
 - (ii) Spindle squamous cell
 - (iii) Verrucous squamous cell
 - (iv) Anaplastic
 - (v) Adenocarcinoma (from mucous glands)
4. Sarcoma

- (i) Fibrosarcoma
- (ii) Chondrosarcoma

TRACHEA, BRONCHI AND LUNGS

A. Congenital

1. Agenesis of one lung
2. Hypoplasia of one or both lungs
3. Bronchogenic cystic disease of the lung

(i) Multiple

- (ii) Single - pneumatocele

4. Cystic adenomatoid malformation

5. Accessory lobes

(i) Azygos

(ii) Cardiac

6. Absence of bronchial connections - sequestration

7. Abnormalities of the pulmonary arteries

8. Tracheo-oesophageal fistula

B. Inflammation of trachea and bronchi

1. Acute laryngo/tracheo-bronchitis

(i) Bacterial/viral

(ii) Atmospheric pollution or irritant gases

(iii) Allergic

2. Chronic bronchitis

A chronic inflammatory condition resulting in the 'Expectoration of sputum on most days for three months or more, for at least two years.'

Types

(i) Simple - only hypersecretion of Mucus

(ii) Obstructive - where the hypersecretion is combined with airways obstruction

Aetiology

(i) Smoking

(ii) Atmospheric pollution

(iii) Persistent or recurrent infection, especially Haemophilus influenzae

(iv) Familial predisposition

Gross features

(i) Muco-purulent secretion

(ii) Symmetrical mild dilatation of bronchi

(iii) Prominent mucous glands which elevate the mucosa

(iv) Frequently associated with emphysema

Microscopic appearances

(i) Bronchial epithelium

a. Goblet-cell hyperplasia

Variable squamous metaplasia

(ii) Bronchial sero-mucinous glands

a. Hypertrophy

b. Increased proportion Of mucous to serous acini

c. Gland to wall-thickness ratio (Reid index) increased

(iii) Submucosa

Chronic inflammatory cell infiltration

Effects

(i) Progressive dyspnoea

(ii) Cor pulmonale

(iii) Cardiac failure

(iv) Respiratory failure

a. Hypercapnia

b. Hypoxaemia

3. Bronchiectasis

Irreversible dilatation of the bronchi, usually associated with inflammation

Aetiology

(i) Inflammatory disease of bronchial walls

a. Unresolved pneumonia

b. Pneumococcal bronchopneumonia

c. Whooping cough

d. Influenza

e. Complicating chronic sinusitis

(ii) Extrinsic pressure on bronchi

a. Lymph node enlargement, e.g. primary tuberculosis, measles

Tumours

- (iii) Intra-luminal obstruction
 - a. Pus and/or fibrinous exudates
 - b. Foreign bodies
 - c. Adenoma/carcinoma
 - d. Tenacious mucus in mucoviscidosis
- (iv) impaired pulmonary defence mechanisms
 - a. Kartagener's syndrome
 - b. Primary ciliary dyskinesia
 - c. Congenital immunodeficiency

Complications

- (i) Lung abscess
- (ii) Empyema thoraces
- (iii) Pyaemia - metastatic abscesses
- (iv) Pulmonary fibrosis
- (v) Cor pulmonale and cardiac failure
- (vi) Secondary to amyloidosis

Bronchial asthma

Types

- (i) Extrinsic
 - a. Atopic asthma, Type I hypersensitivity to exogenous allergens
 - b. Non-atopic, Type III hypersensitivity mediated by circulating precipitins
- (ii) Intrinsic - attacks provoked by a wide variety of stimuli such as anxiety, infection, exercise, smoke, etc.
- (iii) Mixed type

Gross features

- (i) Tenacious mucus plugs
- (ii) Over-distension of lungs
- (iii) Desquamation of epithelium
- (iv) Sputum findings
 - a. Curschmann's spirals
 - b. Charcot-Leyden crystals

Microscopic features in the bronchi

- (i) Lumen filled with basophilic secretion
- (ii) Eosinophils and desquamated epithelium in these plugs
- (iii) Submucosal oedema
- (iv) Infiltration by lymphocytes and eosinophils
- (v) Serous acini increased relative to mucous acini
- (vi) Muscular hypertrophy
- (vii) Thickened basement membrane

Complications

- (i) Status asthmaticus
- (ii) Sudden death
- (iii) Mucus plugging and pulmonary collapse
- (iv) Allergic broncho-pulmonary aspergillosis
- (v) Pneumothorax
- (vi) Mucus hypersecretion

C. Acute pulmonary infections

1. Acute bacterial pneumonia

- (i) Lobar pneumonia - acute diffuse inflammation involving an entire lobe of lung and limited only by the pleura Causes
 - a. Pneumococci; Types 1,2,3 and 5 account for 90-95% of cases
 - b. Klebsiella
 - c. Staphylococci
 - d. Streptococci
 - e. H. influenzae?
 - f. Legionella

Stages

- a. Congestion
- b. Red hepatisation
- c. Grey hepatisation

Complications

- a. Carnification if resolution is incomplete
- b. Empyema
- c. Suppurative pericarditis
- d. Metastatic abscesses, e.g. in brain, kidney

- e. Acute endocarditis
- f. Meningitis
- g. Arthritis
- h. Peritonitis
- (ii) Bronchopneumonia (lobular) - patchy, often multifocal inflammatory consolidation of lung tissue centred around small airways

Causes

- a. Pneumococci
- b. H. influenzae
- c. Staphylococci
- d. Streptococci
- e. Pseudomonas
- f. Klebsiella
- g. Yersinia pestis (plague)
- h. Anthrax ('wool-sorter's disease')

Complications

- a. 'Carnification' - organisation of exudate
- b. Pulmonary fibrosis - scarring in areas destroyed by suppuration
- c. Bronchiectasis
- d. Lung abscess
- e. Empyema
- f. Pericarditis
- g. Metastatic abscesses

Lung abscess

Causes

- (i) Inhalation of infected material, e.g. food, blood clot, teeth, etc.
- (ii) Complicating pneumonia/bronchiectasis
- (iii) Following bronchial obstruction especially due to carcinoma
- (iv) Pyaemic (secondary) abscesses
- (v) Infected thrombo-emboli (especially in drug addicts)
- (vi) Penetrating injuries

Complications

- (i) Scarring and deformity of the lung

- (ii) Empyema
- (iii) Broncho-pleural fistula
- (iv) Pyaemia
- 3. Viral pneumonia Causes
 - a. Influenza
 - b. Adenovirus
 - c. Measles
 - d. Herpes virus (H. simplex and chickenpox)
 - e. Cytomegalovirus
 - f. Respiratory syncytial virus
- 4. Chlamydiae (Bedsonia)
 - a. Psittacosis
 - b. Ornithosis
- 5. Mycoplasmal pneumonia - M. Pneumoniae
- 6. Rickettsial pneumonia - Coxiella burneti

D. Chronic Pulmonary infections

- 1. Tuberculosis
- 2. Actinomycosis
- 3. Nocardiosis
- 4. Fungal infections
 - (i) Aspergillosis
 - (ii) Candidiasis
 - (iii) Phycomycosis
 - (iv) Cryptococcosis
 - (v) Blastomycosis
 - (vi) Histoplasmosis
 - (vii) Torulopsis glabrata
 - (viii) Coccidioidomycosis
- 5. Protozoan infections
 - (i) Pneumocystis carinii
 - (ii) Amoebiasis
- 6. Metazoan infections

SCIO
super learning...

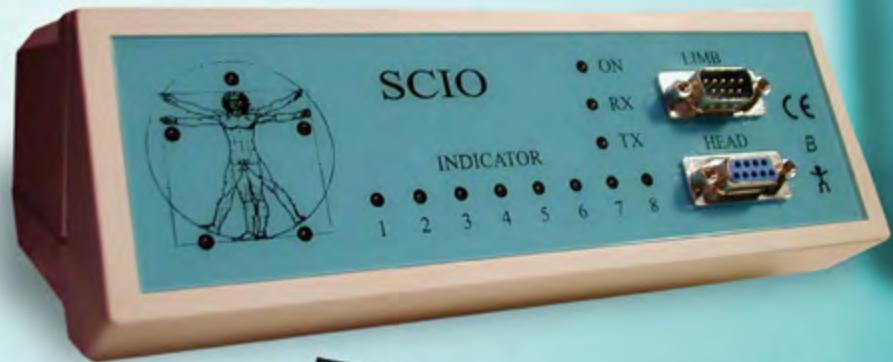

It is scientific fact that when a low level voltage and micro-current pulse is applied to the body osmosis, enzyme activity, and healing are increased. The SCIO will let the patient's body electric autofocus a harmonic pulse to maximize this effect. This current applied to the cranium has been shown to stimulate the learning process and increase memory retention, and learning. There is published research on these therapies. The new world of energetic medicine can help you to learn twice as much in half the time comfortably and easily.



If you need more information on the SCIO and purchase details please get in touch with us

Maitreya Kft.

tel: +3613036043 | web: www.qxsubspace.com | e-mail: info@qxsubspace.com



- (i) Schistosomiasis
- (ii) Paragonimiasis
- (iii) Ascariasis
- (iv) Hydatid disease

E. The Lung in AIDS

1. Opportunistic infections

- (i) Mycobacteria - tuberculosis and atypical species (e.g. *M. avium intracellulare*)
- (ii) Fungi - *Candida*, *aspergillus*, *cryptococcus*
- (iii) Virus - cytomegalovirus, herpes virus
- (iv) Protozoan -

- a. *Pneumocystis carinii*
- b. Toxoplasmosis

2. Lymphoproliferative disorders

- (i) Pulmonary lymphoid hyperplasia
- (ii) Lymphoid interstitial pneumonia
- (iii) Lymphoma

3. Tumours

- (i) Kaposi's sarcoma

F. Diffuse infiltrative lung diseases

Diseases characterised by diffuse inflammation and fibrosis of the connective tissue of the alveolar walls (interstitial fibrosis).

1. Pneumoconioses - diseases caused by the inhalation of dust

- (i) Coal workers'
 - a. Simple pneumoconiosis
 - b. Progressive massive fibrosis
 - c. Caplan's type (with rheumatoid arthritis)
- (ii) Silicosis
- (iii) Asbestosis - also gives rise to:

- a. Pleural fibrosis
- b. Bronchial carcinoma (especially in cigarette smokers)
- c. Mesothelioma

- (iv) Berylliosis
- (v) Siderosis (iron oxide)

- (vi) Stannosis (tin ore particles)
- 2. Physical and chemical agents
 - (i) Cytotoxic drugs - busulphan, bleomycin, cyclophosphamide
 - (ii) Hypersensitivity to drugs - nitrofurantoin, salazopyrine, amiodorone, hexamethonium,
 - (iii) Toxic substances - paraquat poisoning (herbicide)
 - (iv) Radiation
- 3. Immunological diseases
 - (i) Extrinsic allergic alveolitis
 - a. Farmer's lung - Micropolyspora faeni in mouldy hay
 - b. Maltworker's lung - Aspergillus clavatus in malting barley
 - c. Bagassosis - mouldy sugar cane fibres
 - d. Maple bark stripper's disease - Coniosporium corticale in the bark of maple trees
 - e. Bird fancier's lung - avian proteins in bird droppings
 - (ii) Interstitial pneumonias (fibrosing alveolitis)

Types

- a. Usual interstitial pneumonia
- b. Desquamative interstitial pneumonia
- c. Lymphocytic interstitial pneumonia
- (iii) Connective tissue disorders
 - a. Rheumatoid disease
 - b. Systemic lupus erythematosus
 - c. Progressive systemic sclerosis
- (iv) Goodpasture's syndrome - pulmonary fibrosis and glomerulonephritis
- (v) Idiopathic
 - a. Sarcoidosis
 - b. Alveolar proteinosis

G. Pulmonary emphysema

Classification

1. Interstitial emphysema - the presence of air in the interstitial tissue of the lung

Causes

- (i) Tearing of alveolar walls by excessive pressure
 - a. Severe asthma

- b. Whooping cough
- c. Blast injury
- d. Intermittent positive-pressure ventilation
- (ii) Tearing of alveolar walls by direct trauma
 - a. Fractured ribs
 - b. Needle biopsy
- 2. Vesicular emphysema - an increase in size beyond the normal in air spaces distal to terminal bronchioles, that is the pulmonary acini. An acinus contains the respiratory bronchioles, alveolar ducts, and alveoli arising from one terminal bronchiole.
 - (i) Centriacinar (centrilobular) emphysema Distensive type found in
 - a. Urban dwellers
 - b. Coal-miners

Destructive types -more severe form in

- a. Chronic bronchitis
- b. Smoking (inhibition of anti-proteases)

Panacinar (panlobular) emphysema

Distensive type

- a. Lobar emphysema of infancy and childhood
- b. Compensatory emphysema following collapse, agenesis, surgical removal of a lobe(s)

Destructive type

- a. Chronic bronchitis and recurrent bronchopneumonia
- b. a-1-antitrypsin deficiency
- c. Inhalation of cadmium fumes (? in cigarette smoke)

- (iii) Paraseptal (periacinar) emphysema
 - results from inflammation

- (iv) Irregular emphysema

This does not affect the acini in a uniform manner.

Occurrence

- a. relation to scars
- b. giant bullous emphysema
- c. acute tension cysts in infancy

H. Effects of cigarette smoke

1. Mucus hypersecretion

- (i) Epithelial goblet cells increase and extend into bronchioles
- (ii) Hyperplasia of mucus cells in sero-mucinous glands
- (iii) Composition of mucus changes - hyperviscous and tenacious
- 2. Infection resulting from
 - (i) inefficient muco-ciliary escalator
 - (ii) Loss of protective proteins from serous cells of glands and clara cells
 - (iii) Loss of ciliary action in squamous metaplasia
- 3. Emphysema
 - (i) Proteases increase - from inflammatory cells
 - (ii) Anti-proteases decrease - reduced clara cells
 - (iii) Anti-proteases inhibited - direct action of smoke

I. Mechanical disorders

1. Pulmonary atelectasis

A failure of full expansion of the lungs after birth

Causes

- (i) Bronchial obstruction
 - a. Viscid mucus
 - b. Liquor amnii
- (ii) In association with hyaline membrane disease
- (iii) Brain damage involving the respiratory centre
- 2. Lung collapse (after full aeration) Causes
 - (i) Obstruction of the bronchial lumen
 - a. Mucus in asthma mucoviscidosis
 - b. Aspirated material
 - c. After anaesthesia/operations
 - d. Foreign bodies
 - (ii) Extreme narrowing of a bronchus
 - a. Carcinoma
 - b. Inflammatory fibrosis
 - (iii) External pressure on a bronchus
 - a. Enlarged lymph gland
 - b. Aortic aneurysm

- c. Tumour
- (iv) Pressure on the lung
 - a. Pneumothorax
 - b. Pleural effusion
 - c. G-forces in aircrew

J. Tumours

Benign

- 1. Epithelial
 - (i) Papilloma
 - a. Squamous
 - b. Transitional

Both types are exceedingly rare in the bronchi

- (ii) Adenoma These can arise from MUCOUS glands and are either:

- a. Pleomorphic
- b. Monomorphic
- 2. Connective tissue
 - (i) Angioma and sclerosing angioma
 - (ii) Chondroma
 - (iii) Lipoma
 - (iv) Fibroma
 - (v) Neurofibroma

3. Mixed 'tumour'- chondroadenoma (? hamartoma)

Malignant

- 1. Carcinomas Aetiology
 - (i) Cigarette smoking
 - (ii) Atmospheric pollution (?)
 - (iii) Asbestosis
 - (iv) Exposure to arsenic, nickel, haematite, and chromates
 - (v) Exposure to radio-active materials

Varieties

- (i) Squamous carcinoma (via squamous metaplasia)
- (ii) Small cell carcinoma

- (iii) Adenocarcinoma
 - a. Acinar or tubular
 - b. Papillary
 - c. Bronchiolo-alveolar
- (iv) Large cell carcinoma

Rare varieties

- (v) Giant cell carcinoma
- (vi) Clear cell
- (vii) Adeno-squamous
- (viii) Adenoid cystic
- (ix) Muco-epidermoid

Spread

- (i) Local - to pleura, diaphragm, and pericardium
- (ii) Lymphatic - to ipsilateral and contralateral lymph nodes and then to mediastinal, and cervical nodes
- (iii) Blood stream - to:
 - a. Liver
 - b. Adrenals
 - c. Brain
 - d. Bone marrow
 - e. Kidneys
- 2. Carcinoid tumours

Tumours of low-grade malignancy arising from bronchial APUD cells. Part of the spectrum of neuro-endocrine tumours ranging from classical carcinoid tumours through atypical carcinoids to small cell carcinoma.

- 3. Carcino-sarcoma
- 4. Sarcomas
- 5. Pulmonary blastoma
- 6. Malignant lymphoma

PLEURA

A. Inflammation

Acute

- 1. Pleurisy

- (i) Primary viral infections, e.g. Coxsackie B
- (ii) Traumatic injury
- (iii) Secondary to underlying lung disease
 - a. Pneumonia
 - b. Lung abscess
- 2. Empyema - a collection of pus in the pleural space resulting from the introduction of pyogenic organisms through trauma to the chest wall or by spread of infection from:
 - (i) Bacterial pneumonia
 - (ii) Lung abscess
 - (iii) Broncho-pleural fistula
 - (iv) An infected neoplasm
 - (v) Abdominal sepsis

Chronic

- 1. Non-specific, following acute infections
- 2. Tuberculosis
- 3. Asbestosis
- 4. SLE
- 5. Rheumatoid disease
- 6. Actinomycosis
- 7. Fungal infections

Pneumothorax

Causes

- 1. Rupture of sub-pleural bulla
- 2. Trauma (including injection sites)
- 3. Broncho-pleural fistula
- 4. Perforation of the oesophagus with rupture of pleura

C. Tumours

Primary

- (i) Fibrous tumour of pleura - rare and usually benign
- (ii) Mesothelioma - related to previous exposure to asbestos.

The tumours are associated with:

- a. Fibrous or calcified pleural plaques in about 2/3 cases
- b. Pulmonary asbestosis in 12-45%

They show heterogeneous histological patterns:

- a. 'Epithelial' type - acinar or papillary formations resembling adenocarcinoma
- b. Sarcomatous type resembling fibrosarcoma
- c. Mixed types

Secondary

Involvement of the pleura by metastatic tumour is relatively common and frequently presents as a pleural effusion. The major causes of a malignant pleural effusion are:

1. Breast carcinoma
2. Carcinomas of the lung
3. Malignant lymphomas
4. Ovarian carcinomas

23. Urinary system

KIDNEY

A. Renal cystic and dysplastic lesions

1. Developmental lesions
 - (i) Agenesis
 - (ii) Hypoplasia
 - (iii) Heterotopia, e.g. in the pelvis
 - (iv) Fusion - horseshoe kidney
 - (v) Renal dysplasia
 - a. Multicystic (unilateral or bilateral)
 - b. Segmental
 - c. With lower urinary tract obstruction (e.g. posterior urethral valves)
2. Hereditary lesions
 - (i) Polycystic disease
 - a. Infantile
 - b. Adult
 - (ii) Renal medullary cystic disease
 - a. Medullary cystic disease/familial juvenile nephronophthisis
 - b. Medullary sponge kidney
 - (iii) Renal cysts in hereditary syndromes, tuberous sclerosis, etc.
3. Acquired renal cortical cysts

- (i) Simple
- (ii) Multilocular
- (iii) End stage disease of patients receiving maintenance dialysis

B. Inflammatory disorders (mainly affecting the interstitium)

1. Acute pyelonephritis

Acute bacterial infection of the kidney and renal pelvis, usually resulting from ascending infection of the urinary tract, but some cases may result from haematogenous or lymphatic spread.

Pathogenesis

Ascending infection usually follows bacterial contamination of the urine in the bladder with or without true infection of the bladder wall - cystitis

Predisposing factors

- (i) Obstruction, of which the major causes are
 - a. Malformations of the GU tract in childhood
 - b. Pregnancy
 - c. Prostatic hyperplasia and uterine prolapse in the elderly
- (ii) Ureteric reflux
- (iii) Catheterisation
- (iv) Diabetes mellitus

Pathological features

- (i) Kidney is swollen and hyperaemic
- (ii) Surface studded with small abscesses
- (iii) Scattered, rounded or linear abscesses in the cortex and medulla
- (iv) Polymorphs in tubules and interstitium

Complications

- (i) Renal carbuncle
- (ii) Peri-nephric abscess
- (iii) Renal papillary necrosis
- (iv) Acute renal failure
- (v) Pyonephrosis
- (vi) Chronic pyelonephritis
- (vii) Septicaemia
- (viii) Metastatic abscesses

2. Chronic pyelonephritis

Chronic inflammation and fibrosis associated with persistent infection or initiated by infection but becoming self-perpetuating

Pathological features

- (i) Granular, shrunken kidneys
- (ii) Cortical scarring
- (iii) Deformity of the pelvi-calyceal system

Microscopic

- (iv) Tubular atrophy
- (v) Interstitial fibrosis
- (vi) Periglomerular fibrosis
- (vii) Glomerular hyalinisation
- (viii) Chronic inflammatory cell infiltration

Complications

- (i) Hypertension
 - (ii) Chronic renal failure
3. Tuberculosis
- (i) Miliary
 - (ii) Fibro-caseous, nodular tuberculosis
 - (iii) Tuberculous 'pyonephrosis'

C. Glomerular disorders

Definitions

Patterns of involvement by disease are designated:

- (i) Diffuse - all the glomeruli are affected
- (ii) Focal - occasional glomeruli are affected
- (iii) Segmental - only parts of glomeruli are affected

Classification is based on the presence or absence of:

- (i) Mesangial cell and matrix increase if present: proliferative glomerulonephritis (GN)
- (ii) Glomerular basement membrane thickening if present with proliferation: membranoproliferative GN if present alone: membranous GN
- (iii) Crescents
 - >Cr50% of glomeruli: crescentic GN

1. Proliferative glomerulonephritis (GN)

(i) Diffuse endocapillary (exudative) GN

Mesangial cell and matrix increase with swollen endothelial cells and an excess of polymorphs Subepithelial and mesangial deposits containing Ig and complement, i.e. immune complexes

The antigens responsible for these reactions are ill-defined. The classical form of acute diffuse proliferative GN is provoked by streptococcal infection elsewhere in the body, but most cases do not fall into this category.

Other antigens include:

- a. Bacterial endotoxins
- b. Schistosomes
- c. Trypanosomes
- d. Plasmodia
- e. Viral antigens, e.g. hepatitis B, mumps, chicken pox measles
- f. Endogenous DNA

(ii) Diffuse or focal segmental mesangial proliferative GN This pattern of proliferation is a variant also resulting from immune complex deposition. A special form is deposition of IgA in the mesangium seen in Berger's. disease (recurrent haematuria syndrome). Affected patients show an elevated serum IgA and have increased titres to respiratory pathogens including Mycoplasma pneumoniae and influenza virus. The disease may be initiated by respiratory infection.

(iii) Crescentic (extracapillary or rapidly progressive GN)

Pathological features

Segmental necrosis and fibrin deposition in Bowman's space lead to epithelial crescent formation with exudation of inflammatory cells. Superimposed on underlying disease.

This condition has a poor prognosis.

Aetiology

Crescentic GN can supervene on 'acute' proliferative GN, most cases of which are idiopathic, but is also regularly encountered in multisystem diseases:

- a. Malignant hypertension
- b. Infective endocarditis
- c. SLE
- d. Polyarteritis nodosa
- e. Wegener's granulomatosis
- f. Goodpasture's syndrome
- g. Rheumatoid vasculitis

- h. Henoch-Schönlein syndrome
Immunostaining helps to determine the diagnostic category
- a. Linear staining along GBM for IgG, associated with anti-GBM antibody (Goodpasture's)
 - b. Granular staining for immune complex
 - c. Negative in vasculitis such as polyarteritis nodosa or Wegener's
- (iv) Membranoproliferative GN. Often persistent hypocomplementaemia
- Type I (mesangiocapillary GN)

Mesangial interposition and 'double contour' GBM Mesangial and subendothelial deposit of Ig and complement
 - Type II (dense deposit disease)

Intramembranous ribbon-like deposit of extremely electron dense material, also in Bowman's capsule and tubular basement membrane - C3 often, usually no Ig
 - Type III

As type I and numerous subepithelial and intramembranous deposits
Aetiology- idiopathic (rarely associated with immunisation)

Prognosis: usually slowly progressive

2. Minimal change GN

This is the most common cause of the nephrotic syndrome in childhood.

Aetiology

A reaction to lymphokines produced as a hypersensitivity response to toxins, insect stings, pollens, foodstuffs, etc.

Pathological features

- (i) Fusion of epithelial foot processes (EM)
- (ii) Fat droplets in the tubular epithelium

Prognosis

Excellent when treated with corticosteroids or cyclophosphamide

3. Focal glomerulosclerosis

Hyaline thickening of mesangial regions and capillary loops of focal and segmental distribution, usually presenting in childhood as the nephrotic syndrome. The response to treatment is poor. An identical picture can be seen in adults with a wide variety of renal disorders.

4. Membranous GN

Aetiology

In-situ formation of immune complexes within the GBM which activate complement. The increased GBM permeability may be a consequence of membrane attack by the final sequence (C5-9) of

complement. Most cases are idiopathic but known causes include:

- (i) Drug hypersensitivity, particularly to gold and penicillamine
- (ii) Quartan malaria
- (iii) Tumour antigens - e.g. colonic, gastric, and renal adenocarcinoma
- (iv) Hepatitis B
- (v) SLE and rheumatoid disease

Pathological features

- (i) Diffuse thickening of the GBM with 'spike' formation
- (ii) Deposits of immunoglobulin (mainly IgG) and complement C3 beneath the epithelium which later becomes incorporated into the BM
- (iii) Loss of foot processes from the epithelial cells
- (iv) Progressive sclerosis of glomeruli

Prognosis

Usually presents with the nephrotic syndrome and deteriorates slowly to renal failure in 5-10 years

5. Glomerulosclerosis (advanced GN)

The end result of a variety of progressive destructive lesions.

Aetiology

The main causes are:

- (i) Progressive GN
- (ii) Hypertensive nephrosclerosis
Diabetes mellitus
- (iv) Amyloidosis

Pathological features

- (i) Contracted kidneys
- (ii) Hyaline fibrosis of glomeruli
- (iii) Secondary tubular atrophy
- (iv) Interstitial fibrosis
- (v) Associated hypertensive changes

Prognosis

Deterioration to chronic renal failure and death

Pathological basis of the clinical syndromes

- (i) Acute nephritis syndrome
 - a. Diffuse proliferative GN
 - b. Crescentic (rapidly progressive) GN
 - c. Membrano-proliferative GN
 - d. SLE
 - e. Polyarteritis nodosa
 - f. Henoch-Schönlein syndrome
 - g. IgA nephropathy
 - h. Hereditary nephritis
- (ii) Nephrotic syndrome
 - a. Minimal change GN
 - b. Membranous GN
 - c. Proliferative GN
 - d. Focal glomerulosclerosis
 - e. Amyloidosis
 - f. Diabetes mellitus
 - g. SLE
 - h. Renal vein thrombosis
 - i. Congenital nephrotic syndrome
- (iii) Acute renal failure
 - a. Acute tubular necrosis
 - b. Crescentic
 - c. Diffuse proliferative GN
 - d. Severe acute pyelonephritis
 - e. Malignant hypertension
 - f. Polyarteritis nodosa
 - g. SLE
 - h. Eclampsia
 - i. Hypercalcaemia
 - j. Haemolytic-uraemic syndrome
- (iv) Chronic renal failure

- a. Glomerulosclerosis (advanced GN)
- b. Chronic pyelonephritis
- c. Hypertensive nephrosclerosis
- d. Diabetes mellitus
- (v) Painless haematuria
 - a. Berger's (IgA) nephropathy
 - b. Mesangial proliferative GN
 - c. Progressive proliferative GN
 - d. Chronic pyelonephritis
 - e. Hydronephrosis
 - f. Calculus
 - g. Tumours
 - h. Benign recurrent haematuria

D. Tubular disorders

- 1. Acute tubular necrosis
 - (i) Nephrotoxic
 - a. Heavy metals
 - b. Organic solvents
 - c. Ethylene glycol
 - d. Mushroom poisoning
 - (ii) Ischaemic

The causes are those of 'shock'

Pathological features

- (i) Kidneys are swollen and pale
- (ii) Tubular epithelial necrosis, with desquamation of cells forming casts
- (iii) Calcium oxalate crystals in the lumen in some cases
- (iv) Rupture of the tubular basement membrane tubulorrhesis
- (v) Regeneration of epithelium in later stages
- 2. Myeloma kidney
- 3. Bile nephrosis
- 4. Glycogen accumulation
 - (i) Diabetes mellitus

- (ii) Glycogenoses
- 5. Tubular vacuolation
 - (i) Hypokalaemia
 - (ii) Administration of hypertonic solutions
- 6. Disorders of tubular function
 - (i) Defects in transport mechanisms
 - a. Renal glycosuria
 - b. . Phosphaturia
 - c. Renal tubular acidosis
 - d. Familial phospho-gluco-aminoaciduria
 - e. Cystinuria
 - f. Hartnup disease
 - g. Glycine-iminoaciduria
 - h. Glycinuria
 - (ii) Abnormal tubular response to hormones
 - a. Nephrogenic diabetes insipidus
 - b. Pseudohypoparathyroidism
 - c. Pseudohypoaldosteronism
 - d. Pseudohyperaldosteronism

E. Urinary calculi and nephrocalcinosis

Calculi

Calculi are composed of amorphous urinary crystalloids bound by a mucoprotein matrix. They may be found anywhere in the urinary tract but most are formed in the calyces and renal pelvis. The major crystalloids are:

1. Uric acid
2. U rates
3. Oxalates
4. Calcium or magnesium phosphate

Pathogenesis

1. Increased concentration of crystalloids in the urine resulting from:
 - (i) Reduced urine volume as in dehydration
 - (ii) Increased excretion of crystalloids
 - a. Hypercalciuria

- b. Cystinuria
- c. Gout - (uric acid excess)
- 2. Factors favouring the precipitation of crystalloids from 'normal' urine
 - (i) Stasis
 - (ii) Infection. Organisms may split urea and produce alkalinity of the urine which favours the formation of magnesium-ammonium phosphate
 - (iii) Foreign bodies, clumps of bacteria, desquamated epithelial cells, these may act as 'a nidus for crystallisation
 - (iv) Deficiency of stabilising factors such as citrate, colloids, amino acids

Effects

1. Obstruction - hydronephrosis
2. Chronic infection - pyelonephritis
3. Squamous metaplasia
Nephrocalcinosis

Aetiology

1. Hyperparathyroidism
2. Malignancy
 - (i) Hypercalcaemia due to osteolytic deposits
 - (ii) Secretion of parathormone-like hormone by tumour cells
3. Paget's disease of bone particularly during immobilisation
4. Sarcoidosis
5. Vitamin D excess
6. Milk-alkali syndrome
7. Renal tubular acidosis
8. Idiopathic hypercalcaemia of infancy
9. Hyperoxaluria
10. Hyperthyroidism
11. Hypothyroidism in infants

F Vascular disorders

1. Benign nephrosclerosis in essential hypertension
2. Malignant nephrosclerosis
3. Senile arteriosclerotic disease
4. Infarction

- (i) Arterial embolism
 - a. Atrial or mural thrombosis in the heart
 - b. Thrombus from the aorta
 - c. Atherosclerotic debris from ruptured plaques in the upper aorta
 - d. Vegetations from the aortic or mitral valves
- (ii) Arterial thrombosis
 - a. Superimposed on atherosclerosis
 - b. Aortic thrombosis occluding the renal ostium
 - c. Polyarteritis nodosa
- (iii) Involvement of renal ostia by aneurysm
- (iv) Sudden venous occlusion - renal vein thrombosis
- 5. Acute cortical necrosis resulting from DIC in various forms of shock.

G. Tumours

1. Benign

- (i) Cortical adenoma
 - a. Clear cell
 - b. Papillary
 - c. Oxyphil cell
- (ii) Fibroma
 - Haemangioma
- (iv) Angiolipomyoma

2. Malignant

- (i) Adenocarcinoma (hypernephroma)
 - a. Solid-cell type often found in the same tumour
 - b. Clear-cell type
- (ii) Nephroblastoma (Wilms'tumour)
- (iii) Sarcomas (very rare)
- (iv) Transitional cell carcinoma of the renal pelvis
- (v) Squamous cell carcinoma of the renal pelvis (very rare)

BLADDER

A. Congenital

1. Diverticula
2. Ectopia vesicae
3. Persistent urachus

B. Inflammations

Types

1. Acute cystitis
2. Chronic cystitis
3. Special forms of cystitis
 - (i) Follicular
 - (ii) Encrusted - phosphates
 - (iii) Polypoid, including bullous
 - (iv) Interstitial
 - (v) Cystitis cystica
 - (vi) Tuberculous
 - (vii) Malakoplakia
 - (viii) Irradiation
 - (ix) Schistosomiasis (haematobium)

C. Miscellaneous conditions

1. Calculi
2. Diverticulae
3. Fistula
 - (i) Crohn's disease
 - (ii) Malignancy
4. Perforation, most commonly traumatic

D. Tumours

1. Benign or premalignant

- (i) Transitional cell papilloma. To be classified as a papilloma the tumour must:
 - a. Be strictly papillary in pattern
 - b. Show normal transitional cell differentiation throughout
 - c. At no point be more than four cells thick



The Scientific Results are in, the SCIO Works

Published in an ISSN Peer Reviewed Medical Journals

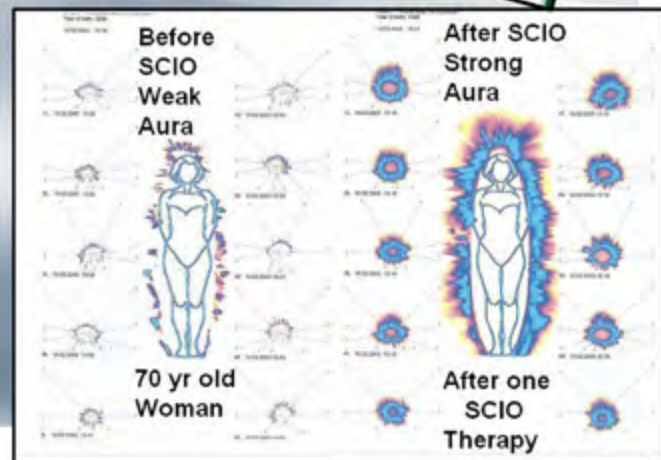
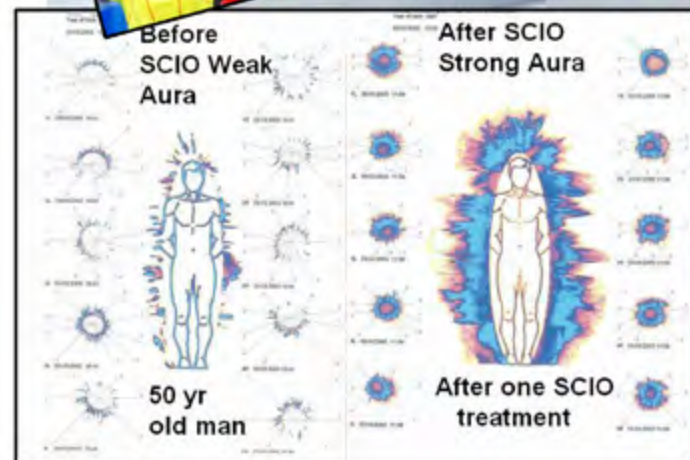
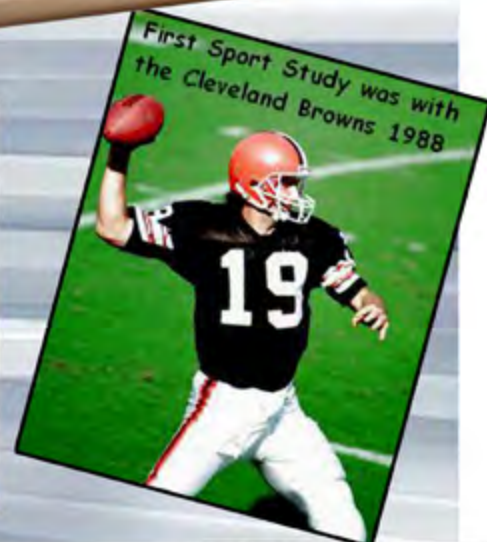

The SCIO will improve the body electric VARHOPE by five% as an average after just one session. The AutoFocusing Harmonic therapies of the Cybernetic Loop of measuring, stimulating, re-measuring, all guided at maximizing the body electric potential will improve your body electric by an average of five%. Improvements of Voltage, Amperage and thus power. Improvements of Resistance and Hydration that means improved enzyme and osmosis transfer of nutrients and detoxification. Improvements in Oxidation meaning more endurance. And improvement in Ph meaning more health. No wonder there are a mile long list of testimonials. Now we can understand why the sport athletes get such great results. A five% improvement is a great edge for a professional sportsman. The patented and proprietary process of the SCIO and QQC have been proven on the world scientific stage to work wonders of improving and stabilizing the body electric.

- d. Show no invasion
- (ii) Dysplasia - mild, moderate, severe or carcinoma-in-situ
- 2. Malignant
 - (i) Transitional cell carcinoma Growth pattern
 - a. Intra-epithelial (carcinoma-in-situ)
 - b. Papillary
 - c. Solid
 - d. Mixed papillary and solid

Cellular structure

Three grades showing progressive anaplasia have been described corresponding to well, moderately and poorly differentiated.

Pathological staging

- pTis - Pre-invasive carcinoma
- pT1 - Infiltration of subepithelial connective tissue
- pT2 - Infiltration of superficial muscle (<halfway)
- pT3 - Infiltration of deep muscle
- pT4 - Invasion of prostate or other extra-vesical structures
- (ii) Squamous carcinoma (arising via metaplasia)
- (iii) Adenocarcinoma
- (iv) Sarcomas, e.g. rhabdomyosarcoma
- (v) Phaeochromocytoma (very rare)

24. Reproductive system

MALE

PROSTATE

- A. Inflammations
 - 1. Non-specific prostatitis
 - (i) Acute
 - (ii) Chronic
 - (iii) Granulomatous
 - 2. Gonococcal
 - 3. Chlamydial
 - 4. Tuberculous prostatitis

5. Eosinophilic (allergic) prostatitis
6. Malakoplakia

B. Nodular hyperplasia

Types Of nodule

1. Mixed stroma and acini (fibromyo-adenomatous)
2. Fibrous or fibrovascular - possibly resulting from previous infarction or foci of inflammation
3. Muscular

Additional features

1. Focal inflammation - acute or chronic
2. Corpora amylacea
3. Calculi
4. Cystic degeneration
5. Infarcts
6. Squamous metaplasia/hyperplasia of the peri-urethral glands

C. Neoplasms

1. Carcinoma

Aetiological factors

- (i) Age - rare under 50
- (ii) Hormones
 - a. ? steroid imbalance
 - b. ? altered sensitivity of prostatic epithelium
- (iii) Race - low incidence in Orientals

Histological types

- (i) Adenocarcinoma
- (ii) Anaplastic
- (iii) Squamous carcinoma arising from metaplastic epithelium in ducts

Behavioural types

- (i) Clinical prostatic cancer - where the disease is producing symptoms
- (ii) Latent cancer - foci of carcinoma found incidentally:
 - at prostatectomy: if multifocal (even low grade), associated with a significant rate of progression if patient less than 60
 - at autopsy: incidence increases with age
- (iii) Occult cancer - the appearance of metastases whilst the primary remains covert

Stages

A = Occult carcinoma

B = Nodule of carcinoma confined within the prostatic capsule

C= Carcinoma has spread outside the capsule with extension into surrounding structures, or confined within the capsule but with elevated serum acid phosphatase

D = Demonstrable skeletal or extra-pelvic involvement

Spread

- (i) Direct: seminal vesicles, rectum, bladder
 - (ii) Lymphatic: iliac, para-aortic glands
 - (iii) Blood: bone, particularly the sacrum and vertebrae
2. Embryonal rhabdomyosarcoma
 3. Leiomyosarcoma
 4. Lymphoma

TESTIS AND EPIDIDYMIS

A. Congenital

1. Undescended testis (cryptorchidism)
2. Absence of one or both testes
3. Fusion
4. Simple cysts
5. Ectopic testes

B. Inflammatory disorders

1. Non-specific epididymo-orchitis
2. Gonococcal epididymo-orchitis
3. Mumps orchitis
4. Tuberculosis (starts in epididymis)
5. Syphilis (starts in testis)
6. Granulomatous orchitis

C. Degenerative disorders

Causes

- (i) Increasing age - ? ischaemic
- (ii) Following orchitis
- (iii) Administration of anabolic steroids
- (iv) Malnutrition

- (v) Post-vasectomy
- (vi) Hyperoestrogenic states
- (vii) Hypopituitarism

D. Vascular disorders

- 1. Torsion of the testis
- 2. Varicocele (varicosity of the pampiniform plexus)

Germ cell tumours

1. Seminoma

The most common testicular tumour - about 40%.

Highly radiosensitive, therefore a good prognosis.

Spread

- (i) Lymphatic: iliac and para-aortic nodes
- (ii) Blood: late spread to liver and lungs

2. Teratoma

Second most common tumour of testes. The prognosis is good with combination chemotherapy unless the disease is extremely advanced at presentation.

- (i) Malignant teratoma differentiated
- (ii) Malignant teratoma intermediate
- (iii) Malignant teratoma undifferentiated

No mature elements are present

This category includes tumours that can be entirely undifferentiated or show some areas of either trophoblastic or yolk sac differentiation. Trophoblastic (malignant teratoma trophoblastic) and yolk sac tumours can also exist as distinct neoplasms

- 3. Combined tumours Seminomas and any type of teratoma can coexist.

Miscellaneous tumours

- 1. Malignant lymphoma (These are more common in older men)
- 2. Spermatocytic seminoma
- 3. Sertoli cell tumour - rare
- 4. Leydig cell tumour - mainly benign tumours secreting androgenic hormones and presenting in childhood with sexual precocity, in adults as a testicular swelling
- 5. Carcinoma of the rete and appendix testis

FEMALE

CERVIX

A. Inflammation

- 1. Acute cervicitis
- 2. Chronic cervicitis - increased numbers of chronic inflammatory cells with, in a few cases, follicle formation. These may indicate chlamydial infection.

- 3. Viral infections

- (i) Herpes simplex
- (ii) Human papilloma virus infection which is manifest as:
 - a. Condyloma acuminata
 - b. Non-condylomatous wart virus infection – koilocytosis

B. Squamous metaplasia and 'erosion'

At puberty and during pregnancy the columnar epithelium of the endocervix extends downwards and occupies part of the ectocervix. This change, which is physiological, is clinically termed an 'erosion'. Subsequently this columnar epithelium undergoes metaplasia to squamous type. This labile area at the squamo-columnar junction is known as the 'transformation zone'

C. Tumour-like lesions

Cervical polyps

- (i) Endocervical or mucous polyp
- (ii) Inflammatory polyp (granulation tissue)

D. Tumours

Benign

Leiomyoma

Malignant

1. Carcinoma

Predisposing factors

- (i) Viral infection (HPV)
- (ii) Low social class
- (iii) Promiscuity, frequency of intercourse, early age of onset of sexual relations
- (iv) Cigarette smoking

Pre-invasive neoplasia (cervical intra-epithelial neoplasia)

- CIN I (mild dysplasia)
- CIN II (moderate dysplasia)

- CIN III (severe/carcinoma-in-situ)

Micro-invasive carcinoma

This is where invasion into sub-epithelial stroma is less than 3 mm. Such carcinomas carry a low risk of lymph node involvement

Histological types of invasive carcinoma

- (i) Squamous carcinoma (70%)
- (ii) Adenocarcinoma (5%)
- (iii) Adeno-squamous (25%)

Staging

Stage 0 = Carcinoma-in-situ (CIN III)

Stage I = Invasive carcinoma confined to the cervix

Stage II = Carcinoma extends beyond the cervix but not to the pelvic wall or lower 1/3 of vagina

Stage III = Carcinoma extends to pelvic wall and/or the lower 1/3 of vagina

Stage IV = Extension beyond the true pelvis or involvement of mucosa of bladder or rectum

Metastatic spread of cervical carcinoma is by Pelvic lymphatics to the para-aortic lymph nodes.

2. Sarcomas

- (i) Leiomyosarcoma
- (ii) Embryonal rhabdomyosarcoma (sarcoma botryoides)

UTERUS

Congenital

Abnormal fusion of the Mullerian ducts leads to:

- (i) Double uterus
- (ii) Septate
- (iii) Bicornuate
- (iv) Bicollis

B. Endometrial inflammation

- 1. Acute endometritis may result in pyometra
- 2. Chronic endometritis
 - (i) Post-partum
 - (ii) IUCD associated
 - (iii) Salpingitis associated
 - (iv) Tuberculous

C. Adenomyosis

Is the presence of endometrial elements in the myometrium. The aetiology is unknown but may represent herniation into the muscle

D. Hormone induced changes in the endometrium

- 1. Dysfunctional uterine bleeding
 - (i) Anovulation
 - (ii) Persistent corpus luteum (delayed shedding)
- 2. Arias-Stella phenomenon - nuclear enlargement and glandular hypersecretion usually found in pregnancy. In the absence of a uterine pregnancy the finding of an Arias-Stella change suggests an ectopic pregnancy.
- 3. Oral contraceptive pill effects
- 4. Senile cystic atrophy
- 5. Hyperplasia
 - (i) Simple hyperplasia - no risk of malignant change
 - (ii) Complex hyperplasia (architectural abnormalities) – low risk
 - (iii) Complex atypical hyperplasia (architectural and cytological abnormalities) - greatest risk of malignancy
- 6. Endometrial polyps

E. Tumours

- 1. Endometrium
 - (i) Adenoma (rare)
 - (ii) Carcinoma

Predisposing factors

Hyperplasia especially complex atypical hyperplasia which may be a consequence of

- a. Obesity
- b. Exogenous oestrogens
- c. Ovarian stromal hyperplasia
- d. Granulosa cell tumours of the ovary
- e. Polycystic ovary syndrome

Histological types

Hyperplasia related:

- a. Adenocarcinoma
 - Unrelated to hyperplasia:
- b. Adenosquamous, where there is a mixture of adenocarcinoma and malignant squamous

elements

- c. Papillary serous
- d. Clear cell

Spread

The prognosis is determined by the depth of myometrial invasion.

- a. Direct to cervix, vagina, vulva and parametrium
 - b. Direct to tubes and ovaries
 - c. Lymphatic to iliac and para-aortic glands
 - d. Blood spread is late - lungs, liver, adrenals and bone
- (ii) Endometrial stromal sarcoma - low-grade or high-grade
 - (iii) Mixed Mullerian tumours (carcino-sarcomas)
 - a. Homologous - derived from uterine components
 - b. Heterologous - from tissues not normally present in the uterus

2. Myometrium

- (i) Leiomyoma (fibroid)
- (ii) Smooth muscle tumour of uncertain malignant potential
- (iii) Leiomyosarcoma

OVARY

1. Endometriosis

Endometriosis is the presence of endometrial glands and stroma in sites other than the uterine corpus. Aetiological theories include retrograde menstruation and Mullerian metaplasia of the mesothelium.

Sites

- (i) Ovaries
- (ii) Fallopian tubes
- (iii) Rectovaginal septum - pouch of Douglas
- (iv) Peritoneum
- (v) Umbilicus
- (vi) Rare sites - vulva, vagina, appendix, intestinal wall

Effects

- (i) 'Chocolate' cyst formation
- (ii) Intra-pelvic haemorrhage
- (iii) Formation of adhesions

- (iv) Endometrioid adenocarcinoma of the ovary
- (v) Infertility

2. Neoplasms

- (i) Epithelial - benign, borderline or malignant
 - a. Serous
 - b. Mucinous
 - c. Brenner
 - d. Endometrioid
- (ii) Germ cell tumours
 - a. Teratoma
 - Mature cystic
 - Immature solid
 - b. Extra-embryonic
 - Yolk sac tumour
 - Choriocarcinoma
 - c. Dysgerminoma
 - d. Malignant mixed germ cell tumours
- (iii) Sex-cord stromal tumours
 - a. Thecoma
 - b. Granulosa cell tumour
 - c. Sertoli-Leydig cell tumour
 - d. Mixed germ cell / stromal tumour (gonadoblastoma)

PLACENTA

1. Hydatidiform mole

The placenta is composed of swollen chorionic villi showing trophoblastic hyperplasia. There is an associated high HCG level and the condition may be complicated by choriocarcinoma. Two types are recognised:

- (i) Complete mole - this has a 46XX karyotype with all the genetic material being paternal (2n). No fetus.
 - (ii) Partial mole - this has a triploid karyotype consisting of male (2n) and female (1n). A fetus may be present.
- ##### 2. Abnormalities of placentation
- (i) Extrachorial

- a. Circum-vallate
- b. Circum-marginate
- (ii) Accessory lobe
- (iii) Placenta accreta - penetration of the myometrium by chorionic villi
- 3. Inflammation

Inflammation (villitis) is associated with fetal growth retardation and death. Most cases are idiopathic but recognised causes include:

- (i) Listeriosis
- (ii) Cytomegalovirus
- (iii) Toxoplasmosis
- 4. Chorionic villous immaturity

Immaturity can give rise to hypoxia, low birth weight and perinatal death.

- 5. Vascular lesions
- (i) Infarcts - occlusion of maternal spiral arteries
- (ii) Thrombosis of fetal villous stem arteries
- (iii) Haemangioma

25. Breast

A. Congenital

- 1. Supernumerary nipples - polythelia
- 2. Supernumerary breasts - polymastia

B. Inflammation

- 1. Acute suppurative mastitis
- 2. Breast abscess
- 3. Mammary duct ectasia (plasma-cell mastitis)
- 4. Fat necrosis
- 5. Tuberculosis
- 6. Silicone mastitis following cosmetic surgery

C. Cystic disease

Fibrocystic disease, cystic mastopathy, mammary dysplasia Microscopic features (found in various combinations)

- 1. Cyst formation (macro- or microcysts)
- 2. Inter- and intralobular fibrosis

- 3. Apocrine metaplasia
- 4. Epithelial proliferation (epitheliosis)
- 5. Ductular proliferation (adenosis)
- 6. Papillomatosis
- 7. Lobular sclerosis (sclerosing adenosis)
- 8. Radial scar

Occasionally, sclerosing adenosis is found as a solitary lesion. In some young women fibrosis is the dominant feature and is associated with premature involution. This form has been designated fibrous disease of the breast.

D. Tumour-like lesions

- 1. Hamartoma
- 2. Microglandular adenosis

E. Tumours

Benign

- 1. Fibroadenoma
 - (i) Intracanalicular
 - (ii) Pericanalicular, including 'giant fibroadenoma'
- 2. Intraduct papilloma
- 3. Adenoma of the nipple
- 4. Tubular adenoma
- 5. Ductal adenoma
- 6. Lactating adenoma
- 7. Lipoma
- 8. Fibroma, haemangioma, etc.

Phyllodes tumour

These tumours (formerly included with giant fibroadenomas) have a structure resembling an intracanalicular fibroadenoma but have a cellular stroma showing varying degrees of atypia. They can be benign, borderline, or malignant.

Malignant

- 1. In-situ (non-invasive) carcinoma
 - (i) Ductal
 - (ii) Lobular
- 2. Infiltrating (invasive) carcinoma
 - (i) Ductal

Varieties

a. Classical

'Special' types

- b. Medullary
- c. Mucinous
- d. Tubular
- e. Papillary
- f. Apocrine
- g. Squamous (?tumour metaplasia)
- (ii) Lobular Varieties
 - a. Classical
 - b. Sparse (paucicellular)
 - c. Solid and pleomorphic - worse prognosis
 - d. Alveolar
 - e. Tubulo-alveolar
- (iii) Adenoid cystic carcinoma
- (iv) Carcinoid (very rare)
- 3. Paget's disease of the nipple

Spread of mammary carcinoma

- 1. Direct
 - (i) Skin - fungating growths
 - (ii) Deep fascia
 - (iii) Muscle
- 2. Lymphatic
 - (i) Axillary and internal mammary lymph nodes
 - (ii) Dermal lymphatics
 - (iii) Widespread dissemination - mediastinal, abdominal, pelvic and inguinal glands
- 3. Serous cavities with effusions
 - (i) Pleura
 - (ii) Pericardium
- 4. Blood stream
 - (i) Lungs

- (ii) Bone
- (iii) Adrenals
- (iv) Ovaries
- (v) Kidneys
- (vi) Brain, etc.

Other malignant tumours of the breast

All are rare

- 1. Fibrosarcoma
- 2. Liposarcoma
- 3. Haemangiosarcoma
- 4. Lymphoma

26. Endocrine system

ADRENAL GLANDS

A. Reactions to stress

- 1. Lipid depletion (compact-cell change)
 - (i) Focal
 - (ii) Diffuse
- 2. Degenerative changes in the zone fascicular cells
- 3. Hemorrhage

B. Hypercorticalism

- 1. Cushing's syndrome

Primary

- (i) Cortical hyperplasia
 - a. Diffuse
 - b. Nodular
- (ii) Adenoma
- (iii) Carcinoma

Secondary

- (i) ACTH and corticosteroid administration
- (ii) Pituitary adenoma (basophil or chromophobe)
- (iii) Non-endocrine tumours producing ACTH
 - a. Carcinoma of the bronchus (oat-cell type)

- b. Thymoma
- c. Medullary carcinoma of thyroid
- d. Islet cell tumours of pancreas

Effects

- (i) Obesity
 - (ii) Hypertension
 - (iii) Osteoporosis
 - (iv) Hyperglycaemia
 - (v) Myopathy
 - (vi) Atrophic change in skin
 - (vii) Polycythaemia
 - (viii) Pituitary changes - Crooke's hyaline degeneration in basophils
 - (ix) Susceptibility to infection
2. Conn's syndrome - (Primary aldosteronism)

Causes

- (i) Cortical adenoma
- (ii) Diffuse or nodular hyperplasia
- (iii) Carcinoma

Effects

- (i) Hypertension
- (ii) Muscle weakness (hypokalaemia)
- (iii) Polyuria and polydipsia
- (iv) Hypernatraemia

3. Adreno-genital syndrome Causes

- (i) Congenital adrenal hyperplasia resulting from a specific enzyme deficiency
- (ii) Cortical adenoma in older children and in adults
- (iii) Carcinoma

Effects

- (i) Congenital type
 - a. Male - enlargement of the penis, rapid growth, early fusion of epiphyses
 - b. Female - pseudohermaphrodite, hirsutism, rapid growth

In addition both may develop hypertension and salt-losing crises

- (ii) Adults
 - a. Female - amenorrhoea, hirsutism, atrophy of the breasts, enlarged clitoris, male musculature

- b. Male - no clinical effects

C. Hypocorticalism

1. Acute adrenal insufficiency resulting from

- (i) Haemorrhagic necrosis
 - a. Shock and stress reactions
 - b. Septicaemia (Waterhouse-Friderichsen syndrome)
 - c. Neonatal hypoxia/birth injury
 - d. Abdominal trauma
- (ii) Sudden deterioration of chronic insufficiency of the adrenal cortex

2. Chronic adrenal insufficiency resulting from:

- (i) Pituitary/hypothalamic disorders
 - a. Simmond's disease
 - b. Sheehan's syndrome
 - c. Iatrogenic
- (ii) Adrenal diseases
 - a. Atrophy (idiopathic)
 - b. Tuberculosis
 - c. Amyloidosis
- d. Fungal infections - histoplasmosis, torulosis, coccidioidomycosis, blastomycosis
- e. Metastatic carcinoma
- f. Haemochromatosis
- g. Following haemorrhagic necrosis
- h. Congenital disorders - hypoplasia with cytomegaly, adreno-genital syndrome
- (iii) Suppression of ACTH production by corticosteroid treatment

Effects

- a. Increased skin pigmentation
- b. Hypotension
- c. Muscle weakness
- d. Hypoglycaemia
- e. Normochromic anaemia

- f. Hyponatraemia
- g. Hyperkalaemia
- h. Reduced renal excretion of water, ammonium ions and urea

D. Tumours

Adrenal cortex

1. Adenoma (the majority are non-functional)
2. Carcinoma
3. Myelolipoma

Adrenal medulla

1. Pheochromocytoma

A tumour of the catecholamine-producing chromatin cells resulting in paroxysmal hypertension.

Associations

- (i) Multiple endocrine neoplasia syndrome (MEN-2, Sipple's syndrome)
- (ii) Neufibromatosis
- (iii) von Hippel-Lindau disease
- (iv) Medullary carcinoma of thyroid
- (v) Parathyroid adenomas

Behaviour

Most are benign, about 10% are malignant.

Metastases are found in lymph glands, lungs, liver and bone

2. Neuroblastoma

A highly malignant tumour of neuroblasts, cells which normally mature into sympathetic ganglion cells. It is a common tumour of childhood.

Sites

- (i) Adrenal medulla
- (ii) Sympathetic chain in posterior mediastinum and abdomen
- (iii) Rare sites, e.g. jaw, bladder

Spread

- (i) Direct local infiltration
- (ii) Lymph glands
- (iii) Blood spread
 - a. Skeletal metastases especially to skull and orbit (Hutchinson type)
 - b. Multiple deposits in the liver (Pepper type)

3. Ganglioneuroma

'Mature' form of neuroblastic tumour with plentiful ganglion cells. These have a much better prognosis.

Both tumours may be associated with catecholamine production.

DIABETES MELLITUS

A metabolic disorder characterised by impaired utilisation of carbohydrates and disturbances in lipid and protein metabolism resulting from an absolute or relative deficiency of insulin.

Aetiology

1. Primary (idiopathic)
 - (i) Juvenile
 - (ii) Maturity-onset
2. Secondary
 - (i) Pancreatic causes
 - a. Pancreatitis
 - b. Carcinoma of the pancreas
 - c. Haemochromatosis
 - d. Pancreatectomy
 - e. 'Glucagonoma'
 - (ii) Adrenal causes
 - a. Cushing's syndrome
 - b. Pheochromocytoma
 - (iii) Pituitary - acromegaly
 - (iv) Thyroid - thyrotoxicosis
 - (v) Drugs - thiazides

Pathological features

1. Islets of Langerhans
 - (i) Degranulation of b-cells
 - (ii) Hyaline deposits and amyloidosis
 - (iii) Fibrosis
 - (iv) Hydropic degeneration of b-cells
 - (v) Lymphocytic infiltration
2. Kidney
 - (i) Arteries and arterioles

- a. Atherosclerosis
- b. Arteriolosclerosis - afferent and efferent
- (ii) Glomeruli
 - a. Diffuse glomerulosclerosis
 - b. Nodular glomerulosclerosis (Kimmelstiel-Wilson lesion)
 - c. Exudative lesions - fibrin cap, capsular drops
- (iii) Tubules
 - a. Glycogen accumulation (Armanni-Ebstein lesion)
 - b. Fatty change
- (iv) Interstitium
 - a. Acute or chronic pyelonephritis
 - b. Fibrosis
- 3. Cardiovascular lesions
 - (i) Arteries
 - a. Atherosclerosis - gangrene, myocardial infarction
 - b. Monckeberg's sclerosis (more common in diabetics)
 - (ii) Arteriolosclerosis
 - (iii) Microangiopathy
- 4. Ocular lesions
 - (i) Capillary microaneurysms
 - (ii) Retinitis proliferans resulting from repeated haemorrhages
 - (iii) Thrombosis of the central retinal vein
 - (iv) Cataracts
- 5. Liver
 - (i) Fatty change
 - (ii) Glycogenic vacuolation of hepatocyte nuclei
- 6. Gall-bladder
 - (i) Cholesterosis increased incidence
 - (ii) Gall-stones
- 7. Neurological lesions
 - (i) Atherosclerotic neuropathy
 - (ii) Diabetic pseudotabes

- (iii) Motor neuropathy
- (iv) Autonomic neuropathy
 - a. Impotence
 - b. Diarrhoea
 - c. Atonic stomach
 - d. Disturbed oesophageal peristalsis
 - e. Bladder dysfunction
- 8. Skin
 - (i) Xanthomata
 - (ii) Necrobiosis lipoidica diabetorum
 - (iii) Infections
 - a. Pyogenic - boils, carbuncles
 - b. Fungal
- 9. Lungs
 - Increased risk of infection
 - a. Bronchopneumonia
 - b. Tuberculosis
- 10. Fetus
 - a. Infants of diabetic mothers show hyperplasia of b-cells (nesidioblastosis) which can cause hypoglycaemia
 - b. Increased birth weight

PITUITARY

Pituitary insufficiency

Aetiology

- (i) Ischaemic necrosis, especially postpartum (Sheehan's syndrome)
- (ii) Tumours
 - a. Chromophobe adenoma
 - b. Craniopharyngioma
 - c. Cholesteatoma
 - d. Metastatic
- (iii) Granulomata
 - a. Sarcoidosis
 - b. Tuberculosis

- c. Congenital syphilis
- d. Idiopathic giant-cell type
- (iv) Infiltrations
 - a. Amyloidosis
 - b. Hand-Schüller-Christian disease
- (v) Trauma

Anterior pituitary failure leads to

- (i) Simmond's disease
 - a. Loss of pigment
 - b. Loss of hair
 - c. Mental deterioration
 - d. Genital atrophy
 - e. Myxoedema
- (ii) Frohlich's syndrome - adipose-genital dystrophy
- (iii) Lorain-type dwarfism

Posterior pituitary failure leads to diabetes insipidus

- 2. Pituitary hyperfunction results from functioning adenomas
 - (i) ACTH - Cushing's syndrome
 - (ii) Somatotropin
 - a. Gigantism
 - b. Acromegaly
 - (iii) Prolactin
 - a. Galactorrhoea
 - b. Amenorrhoea
 - c. Impotence

THYROID

A. Congenital disorders

- 1. Aplasia
- 2. Hypoplasia
- 3. Thyroglossal duct/cyst/fistula
- 4. Lingual thyroid

Call for papers



Call for Papers
for the International Journal of the Medical Science of Homeopathy

The International Medical University of Natural Education
IMUNE who sponsors the International Journal of the
Medical Science of Homeopathy and Natural Medicine
wishes to announce a call for papers. Please send us studies,
letters, comments, articles, photos, testimonials, or stories for
us to consider for publication.

Please send us in acceptable form to:

taflan_andreea@imune.net

B. Thyroiditis

1. Infection

- (i) Acute non-specific
- (ii) Tuberculosis
- (iii) Sarcoidosis
- (iv) Actinomycosis

2. Immune mechanisms

- (i) Hashimoto's disease
- (ii) Focal lymphocytic thyroiditis

3. Physical agents

- (i) Irradiation
- (ii) Trauma

4. Unknown aetiology

- (i) Subacute (giant-cell) thyroiditis - de Quervain's disease
- (ii) Fibrous thyroiditis (Riedel's struma)

C. Hyperthyroidism

Aetiology

- 1. Diffuse thyroid hyperplasia but may result from:
- 2. Overactivity of a multinodular goitre
- 3. Functional (toxic) adenoma
- 4. Hashimoto's disease (rarely)

Diffuse thyroid hyperplasia (Graves' disease)

Aetiology

- (i) ? Long-acting thyroid stimulator - an immunoglobulin
- (ii) ? Pituitary hyperfunction with excess TSH production

Organ changes

- (i) Thyroid
 - a. Enlargement
 - b. Columnar epithelial cells
 - c. Papillary infoldings of epithelium
 - d. Diminished colloid
 - e. Focal lymphocytic infiltration

- (ii) Exophthalmos

- a. Oedema of the orbital contents

- b. Increase in adipose tissue in orbits

- c. Degeneration and fibrosis in extra-ocular muscles

- (iii) Pre-tibial myxoedema

- (iv) Lymphoid hyperplasia

- (v) Heart

- a. Left ventricular hypertrophy

- b. Focal myocardial necrosis

- (vi) Adrenal - hyperplasia

- (vii) Skeletal muscle

- a. Atrophy

- b. Adipose infiltration

- c. Vacuolisation

- (viii) Bones

- a. Osteoporosis

- b. 'Thyroid acropachy' - finger-clubbing resulting from subperiosteal new bone formation

D. Goitre

Types

- 1. Diffuse colloid

- 2. Multinodular

Aetiology

- 1. Iodine deficiency

- 2. Drug-induced (goitrogens)

- (i) Iodides

Thioureas

PAS, etc.

- 3. Inborn errors of metabolism (dyshormonogenic goitre)

- (i) Defective iodide trapping

- (ii) Failure to oxidise iodide to iodine prior to incorporation into tyrosine

- (iii) Failure to couple mono- and diiodotyrosine to form T3 and T4

- (iv) Failure to de-iodinate iodine-containing by-products of T3/T4 synthesis resulting from a lack of iodotyrosine dehalogenase

- (v) An abnormal iodoprotein is produced instead of synthesis of thyroid hormones

Effects

1. Overactivity in some cases, hypofunction in others. Most are euthyroid
2. Pressure on the trachea and oesophagus
3. Haemorrhage into a nodule
4. Malignant change

E. Hypothyroidism

1. Cretinism Aetiology

- (i) Aplasia
 - (ii) Hypoplasia
 - (iii) Inborn error of hormone synthesis
2. Myxoedema

Aetiology

- (i) Primary
 - a. Hashimoto's disease
 - b. Other forms of thyroiditis
 - c. Senile atrophy
 - d. Iodine deficiency
 - e. Goitrogenic drugs
 - f. Thyroidectomy
 - g. Irradiation
- (ii) Secondary
 - a. Pituitary insufficiency (low TSH)

Organ changes

1. Cardiovascular system
 - (i) Congestive cardiomyopathy
 - a. Increased mucopolysaccharide in the interstitium
 - b. Mucoïd vacuolation of myocardial fibres
 - (ii) Atherosclerosis resulting from hypercholesterolaemia
2. Myxoedema
Infiltration of the skin and other tissues by mucoïd oedema
3. Central nervous system

- (i) Mental deterioration
- (ii) Psychosis
- (iii) Stupor and coma

F. Tumours

1. Benign
 - (i) Follicular adenoma Variants
 - a. Colloid adenoma
 - b. Fetal adenoma
 - c. Hürthle cell adenoma
 - (ii) Teratoma (very rare)
2. Malignant
 - (i) Carcinoma arising from thyroid epithelium
 - a. Follicular
 - b. Papillary
 - c. Hürthle cell
 - (ii) Carcinoma arising from calcitonin-producing cells Medullary carcinoma (with amyloid in stroma)
 - (iii) Rare tumours
 - a. Squamous carcinoma (by metaplasia)
 - b. Mucoepidermoid
 - c. Undifferentiated carcinoma
Spindle cell
Giant cell
 - d. Sarcoma
 - e. Lymphoma

PARATHYROID

A. Congenital

1. Abnormal number 2-5
2. Abnormal position, e.g. mediastinum

B. Hyperparathyroidism

Aetiology

Effects

1. Bone

- (i) Osteitis fibrosa cystica
- (ii) Giant-cell granulomas ('brown tumours')
- 2. Metastatic calcification in
 - (i) Kidneys
 - a. Nephrocalcinosis
 - b. Renal calculi
 - (ii) Blood vessels
 - (iii) Lung
 - (iv) Stomach
- 3. Peptic ulceration
- 4. Chronic pancreatitis
- C. Hypoparathyroidism**

Aetiology

- 1. Surgical removal in thyroidectomy
- 2. 'Idiopathic'
 - (i) Hypoplasia/aplasia (as in Di George's syndrome)
 - (ii) Atrophy (? auto-immune)
- 3. Pseudo-hypoparathyroidism (Albright)

Effects

- 1. Tetany
- 2. Mental disturbances
- 3. Epilepsy
- 4. Papilloedema
- 5. Ectodermal changes
 - (i) Dry skin/brittle nails
 - (ii) Eczema
 - (iii) Moniliasis
- 6. Cataracts
- 7. Calcification of the basal ganglia

27. Haemopoietic and lymphoid tissues

HAEMOGLOBIN

Haemoglobin is a conjugated protein composed of four haem groups attached to globin. Haem consists of a tetrapyrrole (porphyrin) ring with a ferrous ion at its centre.

Haemoglobin from effete red cells is normally broken down in reticuloendothelial cells of the spleen, bone marrow, and liver. The protein moiety is detached and broken down into its constituent amino acids which are re-metabolised. The Porphyrin moiety is converted into bilirubin and excreted. The iron (now ferric) combines with protein (apoferritin) to form ferritin. It can be stored in this form, or as a more concentrated iron-protein complex haemosiderin. Iron is transported in the plasma as ferric ion bound to the β globulin transferrin.

Apart from the inherited disorders of globin synthesis (the haemoglobinopathies), haemoglobin and its products are subject to the following disturbances:

- A. Disordered synthesis of haem resulting from abnormal porphyrin metabolism**
- B. Formation of abnormal haemoglobin compounds**
- C. Abnormal storage of iron**
- D. Abnormal bilirubin metabolism and excretion leading to hyperbilirubinaemia**

A. Porphyrin metabolism and its abnormalities

- 1. Disordered synthesis in the liver (hepatic porphyrias)
 - (i) Inherited as autosomal dominants
 - a. Acute intermittent porphyria
 - b. Porphyria variegata (South African type)
 - c. Hereditary coproporphyria

Mechanism

Increased activity of d-aminolaevulate synthetase (ALA-S) in response to a partial blockage of haem formation operating at different points in its synthesis for each disease

Results

- a. Acute abdominal pain
- b. Neuro-psychiatric attacks
- c. Excretion of large quantities of porphobilinogen (PBG) and d-aminolaevulinic acid (ALA) in the urine. The attacks may be precipitated by drugs, especially barbiturates
- (ii) Sporadic - symptomatic cutaneous hepatic porphyria. This is usually a consequence of chronic liver disease, especially chronic alcoholism

Results

- a. Skin photosensitivity

- b. Hypermelanosis
- c. Hypertrichosis
- d. Excretion of large quantities of red-coloured uroporphyrin in the urine
- 2. Disordered synthesis in the bone marrow (erthropoietic porphyries)
 - (i) Congenital erythropoietic porphyria (recessive) Results
 - a. Bulla formation in the skin in response to light and trauma
 - b. Accumulations of uro- and coproporphyrins in the bone marrow, red blood cells and teeth
 - c. Excess excretion of uro- and coproporphyrins in the urine and faeces
 - (ii) Erythropoietic protoporphyria (dominant)
 - a. Photosensitivity of the skin but no bullae in response to trauma
 - b. Increased amounts of protoporphyrin in red cells and faeces but not in the urine
 - c. Cirrhosis of the liver
 - d. Cholelithiasis
 - (iii) Erythropoietic coproporphyria
 - a. Photosensitivity
 - b. Increased coproporphyrins in faeces

B. Abnormal haemoglobin compounds

1. Carboxyhaemoglobin resulting from combination with carbon monoxide and producing a characteristic cherry-red colour in the blood
2. Methaemoglobin results from the conversion of the ferrous to a ferric ion, and in this form cannot combine with oxygen
 - (i) Congenital - due to either a haemoglobinopathy (Hb-M) or a deficiency of methaemoglobin reductase (diaphorase)
 - (ii) Acquired - drug induced, e.g. phenacetin, sulphonamides, nitrates, and other oxidising drugs
3. Sulphaemoglobin - drug induced, e.g. phenacetin, acetanilide

C. Abnormal storage of iron

Iron is normally stored as ferritin or as haemosiderin, which consists of partly denatured ferritin. When excessive quantities require to be stored clumps of haemosiderin appear in the tissues and can be readily demonstrated by Prussian Blue reaction.

Haemosiderin deposition may be localised or generalised:

1. Localised deposits are found in:
 - (i) Areas of haemorrhage in haemosiderin-laden macrophages
 - (ii) Renal tubular cells in haemoglobinuria

- (iii) Siderotic nodules (Gamna-Gandy bodies) in splenomegaly with hepatic cirrhosis
- 2. Generalised deposition may result from:
 - (i) Excessive absorption of iron from the diet due to
 - a. An inborn error of metabolism
 - b. A greatly increased dietary intake
 - c. In thalassaemia, sideroblastic anaemia, and spherocytosis (in the absence of transfusions)

Prolonged increased absorption leads to complete saturation of circulating transferrin and thereafter absorbed iron is present in portal blood in the unbound form. Free iron is toxic and produces chronic cell injury in vascular shunts in the cirrhosis liver, free iron enters the liver resulting in cirrhosis. With the development of systemic circulation and affects other organs, notably the heart and pancreas. A variety of functional disturbances may ensue and this parenchymatous iron storage disease is haemochromatosis.

- (ii) Excessive administration of iron by multiple transfusions or parenteral injections

This usually results in iron deposition in macrophages of the bone marrow, liver, and spleen and is termed haemosiderosis. If administration is prolonged or massive amounts are given, then saturation followed by parenchymatous deposition and fibrosis may result in a picture indistinguishable from haemochromatosis.

Haemochromatosis may affect many organs:

- a. Liver - producing cirrhosis which in turn is associated with an increased incidence of hepatocellular carcinoma
- b. Pancreas - interacinar fibrosis with Pigmentation and atrophy of islets leading to diabetes mellitus
- c. Skin - increase in melanin in the basal layer of the epidermis.

Haemosiderin is also present mainly around skin appendages

- d. Heart - pigmentation and atrophy of myocardial fibres resulting in arrhythmias and cardiac failure
- e. Stomach - rare cases show deposition of haemosiderin in effect on pepsin secretion chief cells of the gastric mucosa but the pigment has little
- f. Spleen - pigmentation and fibrosis
- g. There may be pigmentation and atrophy in testes, thyroid, adrenals and pituitary

ANAEMIA

Anaemia can be defined as a reduction below normal limits of the total circulating red cell mass.

Causes

The major causes of anaemia are blood loss, haemolysis and diminished production.

A. Blood loss

Chronic blood loss, e.g. from the gastrointestinal tract or menorrhagia, results in a microcytic,

hypochromic anaemia

B. Haemolysis

1. Hereditary

(i) Enzyme deficiency

a. Hexose monophosphate shunt enzymes, such as G6PD and glutathione synthetase

b. Glycolytic enzymes - pyruvate kinase, hexokinase

(ii) Membrane defects

a. Disorders of the cytoskeleton - spherocytosis

b. Increased membrane lipids

(iii) Abnormal haemoglobin synthesis

a. Production of abnormal P globin chains - sickle cell anaemia (HBSS), sickle cell trait (HBAS)

b. Deficient P globin synthesis - thalassaemia

2. Acquired

(i) Immune mechanisms

a. Autoimmune reactions which may be idiopathic (primary) or associated with mycoplasma infection, SLE and various malignancies

b. Iso-immune reactions such as drug (haptens) induced haemolysis, transfusion reactions, haemolytic disease of the newborn (erythroblastosis fetalis)

(ii) Membrane defects - paroxysmal nocturnal haemoglobinuria (sensitivity to complement mediated lysis)

(iii) Toxin or chemical injury - snake venoms, lead poisoning

(iv) Infection - malaria

(v) Physical trauma to red cells

a. microangiopathic haemolytic anaemias thrombotic thrombocytopenic purpura, DIC

b. Mechanical injury produced by prosthetic heart valves

C. Diminished red cell production

1. Replacement of the bone marrow

(i) Malignancy

(ii) Myelofibrosis

2. Erythroid stem cell failure

(i) Aplastic anaemia - idiopathic or drug-related

(ii) Pure red cell aplasia

3. Inadequate erythropoietin stimulation

(i) Chronic renal disease

4. Defective DNA synthesis

(i) Folic acid deficiency and folic acid antagonists

a. Malnutrition

b. Chronic alcoholism

c. Malabsorption states

d. Pregnancy

e. Anti-cancer drugs such as methotrexate

f. Anticonvulsant drugs

(ii) Vitamin B12 deficiency

a. Pernicious anaemia

b. Post-gastrectomy

c. Malabsorption states

d. Ileal resection

e. Diffuse intestinal diseases - systemic sclerosis

f. Competition for uptake - fish tapeworm infestation or bacterial overgrowth in 'blind loops'

5. Defective haemoglobin synthesis

(i) Iron deficiency

(ii) Thalassaemia

(iii) 'Anaemia of chronic disease'

(iv) Sideroblastic anaemia

LEUKAEMIA AND MYELOPROLIFERATIVE DISORDERS

These disorders are characterised by replacement of the bone marrow by the progeny of a neoplastic stem cell resulting in disordered haematopoiesis. In acute leukaemia the marrow is rapidly replaced by a Population of immature cells which leads to the acute effects of marrow failure - anaemia, bleeding and susceptibility to infection. In myelodysplasia the marrow is gradually replaced by a neoplastic clone which results in ineffective haemopoiesis with release of abnormal cells into the circulation, inadequate production (pancytopenia), and a variable rate of evolution towards acute leukaemia. A chronic myeloproliferative disorder (CMPD) is one in which the presence of an abnormal clone leads to the over-production of one or more cell lines which can be either red cells, granulocytes, platelets or bone marrow stromal cells. However, these distinctions are blurred by the tendency for both myelodysplasia and chronic myeloproliferative disorders to undergo transformation to leukaemias. CMPD may undergo blast transformation leading to the production of immature cells, frequently of lymphoid type.

Acute leukaemia

Acute leukaemia may arise de novo as well as developing from myelodysplasia or by blast transformation of CMPD. It is divided into myeloid (AML) and lymphoid (lymphoblastic - ALL) types. These are subdivided according to T or B or common differentiation and by some aspects of cellular morphology. Thus AML is subclassified according to whether there is differentiation towards granulocytes, monocytes, erythroid cells or megakaryocytes.

Myelodysplasia

Myelodysplasia (MDS) is probably quite common but in many people remains as a sub-clinical condition. Dysplastic changes can be found as a secondary phenomenon in a large number of conditions such as marrow replacement by carcinoma and following drug treatment. The primary form, however, is characterised by several chromosomal abnormalities including monosomy 7 which points to its essentially neoplastic nature. The proportion of immature myeloid cells in the marrow appears to determine the prognosis: when less than 5% MDS is an indolent disease whereas with levels between 5 and 30% survival declines rapidly. When the proportion of myeloblasts exceeds 30% the diagnosis becomes acute leukaemia.

Chronic myeloproliferative disorders

Over-production of granulocytes, red cells, platelets and stromal cells gives rise to:

1. Chronic myeloid leukaemia (CML) characterised by:
 - (i) Fever
 - (ii) Splenomegaly
 - (iii) Anaemia
 - (iv) Bleeding
 - (v) Hyperviscosity
 - (vi) Progression to acute leukaemia
 - (vii) Presence of the Philadelphia chromosome, a translocation between chromosomes 9 and 22 which results in the transcription of a hybrid gene composed of c-abl - bcr.
2. Primary proliferative polycythaemia (PPP or polycythaemia rubra vera)
 - (i) Raised haemoglobin and packed cell volume
 - (ii) Thrombotic tendency - splenic and renal infarcts
 - (iii) Bleeding
3. Primary thrombocythaemia

Although there are increased numbers of platelets, bleeding occurs because there is a poor response to aggregating agents. Thrombosis in small vessels is another consequence.

4. Myelofibrosis
 - (i) Splenomegaly
 - (ii) Extra-medullary haemopoiesis

- (iii) Normocytic, normochromic anaemia
- (iv) Deformed red cells - tear-drop poikilocytes
- (v) Leucoerythroblastic cells

LYMPHADENOPATHY

A. Non-neoplastic causes of lymphadenopathy

1. Immune response to local infection or inflammation
 - (i) Naso-pharyngeal infection
 - (ii) Genital infection
 - (iii) Dermatopathic reactions
 - (iv) Crohn's disease
 2. Systemic infections involving lymph nodes
 - (i) Infectious mononucleosis
 - (ii) Toxoplasmosis
 - (iii) Tuberculosis
 - (iv) Cat-scratch disease
 - (v) Yersiniosis
 - (vi) Chlamydial infection
 - (vii) Viral infections
 3. Foreign material
 - (i) Silicosis
 - (ii) Anthracosis
 - (iii) Lipid deposits - lipogranulomas
 4. Miscellaneous causes
 - (i) Sarcoidosis
 - (ii) Drug reactions - e.g. phenytoin
- #### B. Neoplastic causes of lymphadenopathy
1. Metastatic tumours - carcinomas, malignant melanoma, seminoma, etc.
 2. Malignant lymphomas which can be divided into:
 - (i) Hodgkin's disease characterised by
 - a. Reed-Sternberg cells which can be either of B or T cell type
 - b. A large population of reactive lymphocytes and histiocytes
 - c. Eosinophils

- d. Contiguous spread along lymph node chains

Prognosis is largely governed by histological type (lymphocyte predominant better than lymphocyte depleted) and the extent of spread (stage) present a diverse and highly

(ii) Non-Hodkins lymphoma (NHL). These lymphomas represent a diverse and highly complex group of neoplasms with currently over 60 different subtypes being recognised. Classification is based on the predominant cell present, the cells corresponding to a certain developmental stage in the differentiation and maturation of lymphocytes. Lymphomas of precursor cells are typically the T- and B-lymphoblastic lymphomas and ALL, whereas neoplastic proliferation of cells in the antigen-dependent phase are much more diverse and consist of either small lymphocytes, germinal centre cells, activated T-cells, or plasmacytoid cells. Grading is derived from the classification into high, intermediate and low grade types. Low grade lymphomas progress slowly but usually show a poor response to chemotherapy. High grade lymphomas progress rapidly but can respond moderately well to chemotherapy.

- (iii) Histiocytosis and myeloid malignancy

Examples:

- a. Langerhans cell histiocytosis
b. Chronic myeloproliferative disorder

MALIGNANT LYMPHOMA AT OTHER SITES

1. Mucosa associated B-cell lymphoma
 - (i) Stomach
 - (ii) Lung
 - (iii) Thyroid
 - (iv) Salivary gland
2. Cutaneous T-cell lymphoma
3. Enteropathy associated T-cell lymphoma of the intestine
4. Myeloma - a neoplasm of bone marrow plasma cells

LYMPHOMAS WITH A LEUKAEMIC PHASE

1. Precursor B- and T- cells - ALL
2. CD5+ B-cells - CLL
3. Pre-plasma cells - hairy cell and lymphoplasmacytoid leukaemia

THYMUS

1. Congenital disorders associated with immune deficiency
 - (i) Aplasia
 - (ii) Hypoplasia
2. Thymic B-cell hyperplasia

3. Thymoma - a malignant tumour of thymic epithelium

Varieties

- (i) Lymphocytic
- (ii) Lymphoepithelial
- (iii) Epithelial
- (iv) Spindle cell

Associations with thymoma

- (i) Myasthenia gravis
- (ii) Red cell aplasia
- (iii) Agammaglobulinaemia
- (iv) Thrombocytopenia
- (v) Cushing's syndrome
- (vi) Auto-immune conditions especially SLE
- (vii) Dermatomyositis and polymyositis
- (viii) Myocarditis

SPLEEN

A. Congenital

1. Agenesis
2. Splenunculi- small rounded nodules of splenic tissue found around the hilum or in the omentum.

B. Inflammation

1. Acute non-specific inflammation - the 'septic' spleen
2. Chronic inflammation
 - (i) Non-specific, as part of a systemic lymphoid hyperplasia
 - (ii) Specific
 - a. Malaria
 - b. Infectious mononucleosis
 - c. Salmonellosis
 - d. Tuberculosis (miliary)
 - e. Sarcoidosis
 - f. Brucellosis

C. Haematological diseases

1. Myeloproliferative

- (i) Leukaemias, especially chronic myeloid
- (ii) Myelofibrosis - extramedullary haematopoiesis

2. Red cell disorders

- (i) Autoimmune haemolytic anaemia
- (ii) Hereditary micro-spherocytosis
- (iii) Sickle-cell anaemia
- (iv) Thalassaemia
- (v) Polycythaemia rubra vera

3. Platelet disorders

- (i) Idiopathic thrombocytopenic purpura
- (ii) Thrombotic thrombocytopenic purpura

D. Vascular disorders

1. Acute congestion

2. Chronic congestion (see p. 137)

- (i) Congestive cardiac failure
- (ii) Portal hypertension

E. 'Storage' disease

1. Carbohydrates

- (i) Galactosaemia
- (ii) Type IV glycogenosis (amylopectinosis)

2. Lipids

- (i) Gaucher's disease (glucosyl ceramide a sphingolipid)
- (ii) Niemann-Pick's disease (sphingomyelin)
- (iii) Generalised (GM) gangliosidosis
- (iv) Wolman's disease (neutral lipids

triglyceride/cholesterol esters)

3. Glycosaminoglycans

4. Miscellaneous

- (i) Mannosidosis
- (ii) Cystinosis

F. Tumours

Benign

- (i) Cavernous haemangioma
- (ii) Lymphangioma

Malignant

- (i) Lymphoma, usually secondary involvement
- (ii) Metastases, these are uncommon. They can be seen in malignant melanoma and in some patients with carcinoma who are immuno-suppressed

28. Connective tissue diseases

A miscellaneous collection of multisystem disorders in which connective tissue effects are prominent. Although formerly called 'collagen diseases', changes in collagen synthesis may not be important clinically nor do they indicate the pathogenesis of the condition. Most are thought to be immunologically mediated.

SYSTEMIC LUPUS ERYTHEMATOSUS

Aetiology

Auto-immune B cell reactions initiated by

1. Genetic predisposition
2. Drugs
 - (i) Hydrallazine
 - (ii) Procainamide
 - (iii) Penicillin
 - (iv) α -Methyldopa
3. Viruses (?)
4. Ultra-violet light
5. Sex hormones

Features

1. Skin
 - (i) Liquefaction/degeneration at the dermal-epidermal junction
 - (ii) Homogenisation of collagen fibres
 - (iii) Fibrinoid necrosis in blood vessels (distinguish from discoid LE)
2. Kidneys
 - (i) Diffuse proliferative GN (immune complex type)
 - (ii) Focal proliferative GN

- (iii) Membranous GN -'wire loop' lesions
- (iv) Vasculitis
- 3. Heart
 - (i) Pericarditis
 - (ii) Myocarditis
 - (iii) Endocarditis atypical verrucous endocarditis (Libman-Sacks)
- 4. Lung and pleura
 - (i) Pleurisy
 - (ii) Pneumonitis
 - (iii) Arteritis
- 5. Joints - inflammation, but not destruction as in RA
- 6. Spleen
 - (i) Perisplenitis
 - (ii) 'Onion skin' arteriolar thickening
- 7. Lymph nodes
 - (i) Follicular hyperplasia
 - (ii) Focal necrosis
- 8. CNS
 - (i) Epilepsy
 - (ii) Mental/hypothalamic features
 - (iii) Myasthenic syndrome

PROGRESSIVE SYSTEMIC SCLEROSIS (SCLERODERMA)

A disease characterised by excessive fibrosis throughout the body.

Features

- 1. Skin
 - (i) Pigmentation
 - (ii) Epidermal atrophy with loss of appendages
 - (iii) Dermal oedema and separation of collagen
 - (iv) Calcinosis
- 2. Lungs
 - (i) Interstitial fibrosis - honeycomb lung
 - (ii) Vascular changes

- 3. Kidneys
 - (i) Basement membrane thickening
 - (ii) Fibrinoid necrosis in arterioles
 - (iii) Cortical infarcts
- 4. Alimentary tract
 - (i) Collagenous thickening - hypomotility
 - (ii) Pseudo-obstruction
- 5. Blood vessels
 - (i) Intimal proliferation and medial hypertrophy
 - (ii) Fibrinoid necrosis
- 6. Muscle
 - (i) Atrophy
 - (ii) Myositis
- 7. Joints
 - (i) Synovitis
 - (ii) Synovial sclerosis
- 8. Heart
 - (i) Myocardial fibrosis
 - (ii) Pericarditis
- 9. Thymus
 - (i) Lympho-epithelial proliferation
 - (ii) Enlarged Hassall's corpuscles

POLYARTERITIS NODOSA

Disseminated necrotising inflammation affecting medium-sized and small arteries.

Features

- 1. Medial fibrinoid necrosis
- 2. Polymorph infiltration
- 3. Destruction of the internal elastic lamina
- 4. Super-imposed thrombosis
- 5. Fibroblastic proliferation
- 6. Infiltration by lymphocytes, plasma cells, eosinophils
- 7. Increasing collagenisation

Results

1. Haemorrhage
2. Infarction
3. Aneurysmal dilatation

Organs affected

1. Kidneys
 - (i) Focal necrosis
 - (ii) Proliferation - crescent formation
 - (iii) Granular deposits and fibrin (GBM)
2. Heart
3. Liver
4. Gastrointestinal tract
5. Lungs
6. Peripheral nerves

RHEUMATOID DISEASE

This is a chronic relapsing multisystem disease of unknown aetiology.

Extra-articular lesions

1. Nodules
 - (i) Subcutaneous tissue
 - (ii) Lungs and pleura
 - (iii) Heart - base of valves
 - (iv) Dura mater
2. Bones
 - (i) Periarthrodal osteoporosis
 - (ii) Generalised osteoporosis resulting from:
 - a. immobilisation
 - b. steroid therapy
3. Heart
 - (i) Nodules
 - (ii) Pericarditis
 - (iii) Coronary arteritis
4. Blood vessels

- (i) Vasculitis
- (ii) Intimal proliferation leading to occlusion

5. Lungs

- (i) Diffuse interstitial fibrosis
- (ii) Nodular lung disease
- (iii) Rheumatoid pneumoconiosis (Caplan's syndrome)

6. Lymph nodes - follicular hyperplasia

7. Secondary amyloidosis

8. Kidneys - secondary involvement due to

- (i) Arteritis
- (ii) Amyloid
- (iii) Analgesics

9. Eyes

- (i) Keratoconjunctivitis sicca
- (ii) Episcleritis
- (iii) Scleromalacia perforans
- (iv) Uveitis

10. Nerves

- (i) Secondary to vasculitis
- (ii) Compression
- (iii) Amyloidosis
- (iv) Drugs

11. Muscle

- (i) Atrophy secondary to neuropathy
- (ii) Steroid myopathy

12. Thyroid

Increased incidence of

- (i) Thyrotoxicosis
- (ii) Hashimoto's disease

13. Sjögren's syndrome (kerato-conjunctivitis sicca)

QX World Conference 2010

"Energetic Medicine and the SCIO in depth"

Budapest, Hungary 07-10 October 2010

Every year in October, Prof William "Bill" Nelson invites you to the "QX World Conference" in the beautiful European city of Budapest, Hungary. Prof Nelson and his office staff, The Budapest Home Office, are the creator and manufacturer of the universal electrophysiological biofeedback system, the SCIO. Prof Nelson and his staff are living and working out of Budapest and this is a chance to meet them as well as numerous other Trainers and Speakers from around the world covering various topics connected to the device.

The International Medical University of Natural Education IMUNE who sponsors the International Journal of the Medical Science of Homeopathy and Natural Medicine wishes to invite all and any to attend our yearly world congress on medicine. If you would like to present material please send us a proposal. Please send us studies, letters, comments, articles, photos, testimonials, or stories for us to consider for publication.

If you wish to give a workshop, or have a booth please send us a proposal.

Please send us in acceptable form to:

Edit Barota - Conference Organizer
edit@qxsubspace.com



29. Musculo-skeletal system

SKELETAL MUSCLE

A. Muscular dystrophy

1. Myotonic
 - (i) Myotonia dystrophica
 - (ii) Congenital myotonia (Thomsen's disease)
 - (iii) Paramyotonia congenita
2. Non-myotonic
 - (i) Duchenne type (pseudo-hypertrophic)
 - (ii) Becker type
 - (iii) Facioscapulohumeral
 - (iv) Limb-girdle
 - (v) Distal muscular type
 - (vi) Ocular muscular type

B. Myopathies

1. Congenital
 - (i) Benign congenital hypotonia
 - (ii) Fibre type disproportion
 - (iii) Central core disease
 - (iv) Nemaline myopathy
 - (v) Myotubular myopathy
 - (vi) Arthrogryposis multiplex congenita
2. Metabolic
 - (i) Glycogenoses
 - a. Type V (McArdle's)
 - b. Type VII (Tare's)
 - c. Also in type II (Pompe's disease), type III and sometimes type IV
 - (ii) Periodic paralysis syndromes
 - a. Hypokalaemic
 - b. Hyperkalaemic
 - c. Normokalaemic
 - (iii) Hypercalcaemia

3. Endocrine

- (i) Hyperthyroidism
- (ii) Hypothyroidism
- (iii) Hyperparathyroidism (unrelated to plasma calcium)
- (iv) Cushing's syndrome
- (v) Hyperaldosteronism
- (vi) Hypopituitarism

4. Toxic

- (i) Steroids
- (ii) Chloroquine
- (iii) Alcohol
- (iv) ? Malignant hyperpyrexia after general anaesthesia

5. Collagen diseases

- (i) Acute rheumatic fever
- (ii) SLE
- (iii) Polyarteritis nodosa
- (iv) Polymyalgia rheumatica

6. Infection/infestation

- (i) Coxsackie B virus (Bornholm)
- (ii) Syphilis
- (iii) Toxoplasmosis
- (iv) Trypanosomiasis
- (v) Trichinosis
- (vi) Cysticercosis

7. Carcinoma-associated

- (i) Neuromyopathy
- (ii) Myopathy
- (iii) Myasthenic-myopathic syndrome

8. Sarcoidosis

C. Myasthenia gravis

Muscle disease characterised by weakness and resulting from a deficiency, or premature breakdown, of acetylcholine.

Associations

- (i) Thymoma
- (ii) Hyperthyroidism
- (iii) Diabetes mellitus
- (iv) SLE
- (v) Rheumatoid disease

D. Rhabdomyolysis

Acute muscle breakdown with myoglobinuria resulting from:

- (i) Excessive physical exertion (e.g. marathon running)
- (ii) Virus infection
- (iii) Alcohol excess
- (iv) Drugs
- (v) Trauma (crush syndrome)

E. Tumours

1. Granular cell myoblastoma
2. Rhabdomyosarcoma
 - (i) Embryonal alveolar type
 - (ii) Embryonal botryoid type
 - (iii) Adult pleomorphic type

FIBROMATOSSES

A. Congenital and juvenile

1. Fibrous hamartoma of infancy
2. Fibromatosis colli (congenital torticollis)
3. Infantile fibromatosis
 - (i) Dermal
 - (ii) Diffuse
4. Juvenile fibromatosis
5. Juvenile aponeurotic fibroma
6. Congenital generalised fibromatosis

B. Miscellaneous types

1. Palmar fibromatosis (Dupuytren's contracture) and its plantar variant
2. Musculo-aponeurotic fibromatosis (desmoids)

3. Mesenteric fibromatosis
4. Hereditary gingival fibromatosis
5. Generalised multifocal fibromatosis

BONES

A. Congenital

1. Achondroplasia
2. Dyschondroplasia
3. Chondro-osteodystrophy (Morquio)
4. Osteogenesis imperfecta
5. Osteopetrosis
6. Marfan's syndrome
7. Gargoylism (Hunter-Hurler)

B. Inflammatory

Non-specific suppurative osteomyelitis

Features

- (i) Pus formation
- (ii) Necrosis of bone resulting from toxic and ischaemic injury (sequestrum)
- (iii) Reactive new bone formation (involucrum)
- (iv) Drainage of pus via cloacae and sinuses to the skin

Complications

- (i) Septicaemia
- (ii) Metastatic abscesses
- (iii) Suppurative arthritis
- (iv) Amyloidosis
2. Tuberculosis
3. Syphilis
 - (i) Osteochondritis
 - (ii) Periosteitis with cortical thickening - sabre tibia
 - (iii) Gummatous destruction - 'worm-eaten' skull
4. Fungal
 - (i) Blastomycosis
 - (ii) Coccidioidomycosis

5. Actinomycosis

C. Osteoporosis

Reduction in calcified bone mass - generalised atrophy of bone. The disease probably represents an involutinal or ageing phenomenon in which there is diminished osteoblastic activity without a corresponding reduction in osteociasis.

Aetiology

1. Idiopathic
 - (i) Senile
 - (ii) Postmenopausal
2. Malnutrition
3. Hypovitaminosis C
4. Prolonged immobilisation
5. Endocrine
 - (i) Corticosteroid treatment/Cushing's syndrome
 - (ii) Hyperthyroidism
 - (iii) Acromegaly
 - (iv) Hypopituitarism
6. Chronic liver and renal disease

D. Osteomalacia/rickets

Inadequate mineralisation of bone matrix resulting in a relative increase in the amount of osteoid.

Aetiology

1. Vitamin D deficiency
 - (i) Malabsorption syndromes
 - (ii) Dietary deficiency
 - (iii) No exposure to sunlight
2. Associated with hypophosphataemia
 - (i) Renal tubular acidosis
 - (ii) Familial hypophosphataemia (vitamin-D resistant)
 - (iii) Fanconi's syndrome
 - (iv) Part of renal osteodystrophy
3. Defective mineralisation but with normal calcium, phosphorus and vitamin D levels
 - (i) Hypophosphatasia
 - (ii) Fluoride excess

E. Paget's disease (osteitis deformans)

A combination of osteoclastic resorption of normal bone and osteoblastic regeneration or primitive coarse-fibred bone lying in a richly vascular fibrous stroma.

Types

1. Monostotic - e.g. tibia
2. Polyostotic - pelvis, skull, femur, tibia
3. Localised - sharply outlined resorptive area in the skull (osteoporosis circumscripta)

Complications

1. Deformity
2. Pathological fracture
3. Encroachment on foramina producing nerve defects
4. Flattening of the base of the skull (platybasia)
5. Cardiac failure - high output required because of vascular shunts
6. Development of sarcoma (1-2%)
7. Hypercalcaemia when immobilised

F. Tumours

Osteogenic tumours

Benign

1. Osteoma
2. Osteoid osteoma
3. Osteoblastoma - 'giant osteoid osteoma'

Malignant

1. Osteogenic sarcoma
2. Parosteal osteosarcoma

Cartilaginous tumours

Benign

1. Osteochondroma - osteochondrogenous exostosis
 - (i) Single
 - (ii) Multiple
2. Chondroma
 - (i) Ecchondroma
 - (ii) Enchondroma
 - Multiple in Ollier's disease

Associated with haemangiomas in Maffucci's syndrome

3. Chondroblastoma - Codman's tumour
4. Chondromyxoid fibroma

Malignant

1. Chondrosarcoma
2. Mesenchymal chondrosarcoma

Fibrous tumours

Benign

1. Non-osteogenic fibroma
2. Ossifying fibroma
3. Fibromyxoma

Malignant

1. Fibrosarcoma
2. Malignant fibrous histiocytoma

Giant-cell 'tumours'

1. True giant-cell tumour
2. Giant-cell reparative granuloma of jaw
3. 'Brown tumours' of hyperparathyroidism
4. Simple bone cyst
5. Aneurysmal bone cyst

Tumours arising from bone-marrow

1. Leukaemias
2. Multiple myeloma
3. Malignant lymphomas

Other tumours

1. Ewing's tumour
2. Chordoma
3. Haemangioma
4. Neurofibroma
5. Adamantinoma of long bones

Metastatic tumours

Childhood - neuroblastoma

Adult

1. Osteosclerotic carcinomas
 - (i) Prostate
 - (ii) Breast
 - (iii) Adenocarcinoma of bronchus
 - (iv) Signet-ring type of gastric carcinoma
2. Osteolytic carcinomas
 - (i) Renal
 - (ii) Thyroid
 - (iii) Colon
 - (iv) Breast
3. Unchanged - oat -cell carcinoma of bronchus

Histiocytosis X

1. Eosinophil granuloma
2. Hand-Schüller-Christian disease
3. Letterer-Siwe disease

JOINTS

A. Arthritis in systemic diseases

1. Gout
2. Psoriasis
3. Ulcerative colitis and Crohn's disease
4. Sarcoidosis
5. Immune-complex deposition
 - (i) Rubella
 - (ii) Hepatitis B
 - iii) Serum sickness

B. Osteoarthritis

Aetiology

1. Primary - degeneration
2. Secondary

- (i) Trauma
- (ii) Obesity
- (iii) Osteochondritis
- (iv) Developmental - e.g. congenital dislocation
- (v) Haemophilia
- (vi) Ochronosis
- (vii) Acromegaly

Features

1. Fibrillation of cartilage
2. Fragmentation
3. Exposure of bone with thickening - eburnation
4. Marginal new bone formation - osteophytes
5. Fibrosis of underlying bone - radiological 'cysts'

C. Rheumatoid arthritis

Features

1. Synovial inflammation
2. Accumulation of fibrinoid material on the synovium
3. Enlargement of synovial villi resulting from oedema, proliferation and cellular infiltration (lymphocytes and plasma cells)
4. Erosion of cartilage at the margins
5. Replacement by granulation tissue - pannus
6. Fusion of articular surfaces by fibrosis ankylosis, or subluxation of the joint

30. Nervous system

BRAIN AND SPINAL CORD

A. Congenital

1. Abnormalities of fusion
 - (i) Spina bifida occulta
 - (ii) Meningocele
 - (iii) Meningomyelocele
 - (iv) Myelocele-rachiscisis
 - (v) Encephalocele
 - (vi) Anencephaly - cranioscisis

2. Abnormalities of cleavage
 - (i) Cyclopia
 - (ii) Arrhinencephaly
 - (iii) Telencephalon impar
 3. Abnormalities of migration of neuroblasts
 - (i) Ectopias
 - (ii) Pachygyria
 - (iii) Microgyria
 4. Others
 - (i) Porencephaly - communication between the ventricular system and the sub-arachnoid space
 - (ii) Hypoplasia of the cerebellum
 - (iii) Absence of the corpus callosum
- B. Hydrocephalus**
1. Obstruction to CSF flow
 - (i) Congenital malformations
 - a. Arnold-Chiari malformation
 - b. Stenosis of the aqueduct
 - c. Dandy-Walker syndrome
 - d. Atresia or stenosis of the foramina of Magendie and Luschka
 - (ii) Post-inflammatory
 - a. Meningitis
 - b. Trauma
 - (iii) Space-occupying lesions
 - a. Neoplasms
 - b. Cysts
 - c. Abscesses
 - d. Haematomata
 2. Defective absorption
 - (i) Adhesions over the cerebral hemispheres
 - (ii) Organised exudate around arachnoidal villi
 - (iii) Thrombosis of the major venous sinuses

3. Excessive production of CSF. Papilloma of the choroid plexus (very rare)
4. Mechanism unknown
 - (i) Idiopathic cases
 - (ii) 'Normal pressure hydrocephalus'

C. Meningitis

Predisposing factors

1. Local infection, e.g. otitis media, mastoiditis
2. Distant infection, e.g. tuberculosis, pneumococcal pneumonia
3. Trauma, e.g. frontal fractures

Varieties

1. Pyogenic (purulent or suppurative)
 - (i) Neonatal
 - a. Gram-negative bacilli:
 - E-coli
 - Proteus spp
 - Pseudomonas spp
 - b. Streptococcus
 - c. Staphylococcus
 - d. Haemophilus influenzae
 - e. Listeria monocytogenes
 - (ii) Infant
 - a. H. influenzae
 - b. Meningococcus
 - c. Pneumococcus, etc.
 - (iii) Children and young adults
 - a. Meningococcus
 - b. Pneumococcus, etc.
 - (iv) Elderly
 - a. Pneumococcus, etc.
2. Viruses
 - (i) Mumps
 - (ii) Enteroviruses:

- a. Echo
- b. Coxsackie
- c. Poliomyelitis
- (iii) Herpes zoster
- (iv) EB virus
- (v) Lymphocytic choriomeningitis virus
- 3. Granulomatous diseases
 - (i) Tuberculosis
 - (ii) Syphilis
 - (iii) Sarcoidosis
 - (iv) Cryptococcus neoformans infection
- 4. Fungi
 - (i) Histoplasmosis
 - (ii) Coccidioidomycosis
 - (iii) Mucormycosis
 - (iv) Torulosis
- 5. Rickettsia
- 6. Protozoa
 - (i) Toxoplasmosis
 - (ii) Free-living amoebae:
 - a. Hartmanella
 - b. Naegleria

D. Cerebral abscess

Predisposing factors

- 1. Local infection, e.g.
 - (i) Otitis media/mastoiditis
 - (ii) Sinusitis
 - (iii) Venous sinus phlebitis
- 2. Distant infection with blood spread, e.g.
 - (i) Bronchiectasis
 - (ii) Empyema
 - (iii) Lung abscess

- (iv) Acute endocarditis
- 3. Penetrating injury or surgery
- 4. Cyanotic heart disease, with R to L shunts organisms by -pass the Pulmonary vascular 'filter'

E. Viral encephalitis

- 1. Primary-arboviruses
 - (i) Transmitted by mosquitoes:
 - Group A - Eastern equine encephalitis; Western equine encephalitis; Venezuelan equine encephalitis
 - Group B - St Louis encephalitis; Murray Valley encephalitis; Japanese encephalitis
 - (ii) Tick-borne encephalitis: Russian spring-summer Central European
- 2. Secondary to Systemic infection (which may be inapparent)
 - (i) Herpesvirus hominis
 - (ii) Mumps
 - (iii) Varicella
 - (iv) Measles
 - (v) Echo viruses
 - (vi) Cytomegalovirus
- 3. Slow-virus infections
 - (i) Kuru
 - (ii) Jakob-Creutzfeldt disease

F. Vascular disorders

- 1. Meningeal haemorrhage
 - (i) Extradural - haemorrhage between the skull and the dura resulting from trauma
 - (ii) Subdural - haemorrhage from cortical veins between the dura and the arachnoid, usually a result of trauma but may occasionally follow rupture of a berry aneurysm
 - (iii) Subarachnoid - haemorrhage between the arachnoid and pia resulting from:
 - a. Rupture of a 'berry' aneurysm
 - b. Extension from an intracerebral haemorrhage
 - c. Traumatic
- 2. Intracerebral haemorrhage
 - (i) Massive haemorrhage resulting from
 - a. Hypertensive cerebral vascular disease

- b. Ruptured aneurysm
- c. Trauma
- d. Bleeding diathesis
- e. Angiomas/vascular malformations
- f. Bleeding into a tumour
- (ii) Scattered punctate haemorrhages
- a. Cerebral contusion
- b. Asphyxia
- c. Fat or air embolism
- d. Infections - viral encephalitis, septicaemia
- e. Bleeding diathesis
- 3. Anoxic - ischaemic injury

Aetiology

- (i) Cardiac arrest
- (ii) Systemic hypotension
- (iii) Respiratory failure
- (iv) Severe anaemia
- (v) Poisoning - carbon monoxide, nitrous oxide, etc.
- (vi) High altitude

Regions most vulnerable to hypoxia

- (i) Hippocampus
- (ii) Purkinje cells of the cerebellum
- (iii) Small pyramidal cells of frontal and occipital cortex
- (iv) Amygdaloid nucleus
- (v) Brain stem

Cellular changes

- (i) Neuronal degeneration and disappearance
- a. Swelling and pallor of cytoplasm
- b. Loss of Nissl substance
- c. Pyknosis and acidophilic shrinkage necrosis
- d. Karyolysis
- e. Neuronophagia

- (ii) Astrocyte proliferation and glial scarring
- 4. Non-infarctive ischaemia resulting from gradual narrowing of small arteries and arterioles by
 - (i) Hyaline thickening of the media (hypertension/diabetes)
 - (ii) Adventitial sclerosis

Effects

- (i) Formation of lacunae - small cystic cavities 2-10 mm diameter
- (ii) Granular cortical atrophy in 'watershed' areas
- (iii) Status cribrosus - 1-2 mm zones of degeneration around small perforating vessels of the basal ganglia
- (iv) Binswanger's subcortical encephalopathy - focal demyelination of white matter due to selective involvement of deeper arterial branches

5. Cerebral infarction Aetiology

- (i) Occlusion or narrowing of cerebral, vertebral and internal carotid arteries by
 - a. Atherosclerosis
 - b. Thrombosis
 - c. Embolism
- (ii) Arteritis/thrombosis
 - a. Complicating meningitis
 - b. Endarteritis obliterans in syphilis
 - c. Polyarteritis nodosa
 - d. SLE
 - e. Giant-cell arteritis

Cellular changes

- (i) Ischaemic degeneration of neurones
- (ii) Myelin pallor
- (iii) Destruction of myelin sheaths and axis cylinders
- (iv) Macrophage activity - ingestion of myelin and red blood cells
- (v) Astrocytic proliferation - gliosis

Macroscopic changes

- (i) Softening
- (ii) Liquefactive (colliquative) necrosis
- (iii) Cyst formation

G. Disorders of myelination

1. Defective myelination due to an inherited defect

- (i) Metachromatic leucodystrophy (accumulation of sulphatide)
- (ii) Krabbe's disease (galactocerebroside)
- (iii) Pelizaeus-Merzbacher disease
- (iv) Spongiform degeneration of the white matter - Canavan disease

2. Acquired demyelination

- (i) Multiple sclerosis

Lesions (plaques) most commonly found in

- a. Optic nerves
- b. Around the lateral ventricles
- c. Brain stem
- d. Cerebellar peduncles
- e. Dorsal spinal cord

Microscopic features

- a. Loss of myelin
- b. Perivascular lymphocytic infiltration
- c. Marked reactive gliosis
- (ii) Neuromyelitis optica (Devic's disease - probable variant of MS)
- (iii) Acute disseminated encephalomyelitis
- (iv) Diffuse cerebral sclerosis (Schilder's disease)
- (v) Subacute sclerosing panencephalitis (prolonged cerebral measles virus)
- (vi) Progressive multifocal leucoencephalopathy caused by papova virus infection in immunocompromised individuals
- (vii) Post-vaccination encephalitis
- (viii) Post-infectious encephalitis

H. Metabolic disorders

1. Neuronal storage disorders

- (i) Tay-Sachs' disease
- (ii) Niemann-Pick's disease
- (iii) Gaucher's disease
- (iv) Hunter-Hurler disease

2. Phenylpyruvic oligophrenia

3. Maple-syrup urine disease

4. Galactosaemic oligophrenia

5. Porphyric myelopathy

6. Wilson's disease

7. Hallervorden-Spatz disease (iron-containing pigment in the globus pallidus and substantia nigra)

I. Degenerative disorders

1. Alzheimer's disease

Features

- (i) Cerebral atrophy
- (ii) Neuronal loss
- (iii) Senile plaques in grey matter
- (iv) Neurofibrillary degeneration ('tangles')

2. Parkinson's disease

- (i) Idiopathic (paralysis agitans)

Features

- a. Loss of pigmented neurones from the substantia nigra, locus ceruleus, and motor nucleus of X
- b. Rounded acidophilic inclusions in neurones - Lewy bodies
- c. Gliosis some cases have
- d. Autonomic degeneration with postural hypotension (Shy-Drager syndrome)
- (ii) Postencephalitic

Features

- a. Loss of pigmented neurones from the substantia nigra and occasionally from the locus ceruleus
- b. Neurofibrillary tangles in affected neurones
- c. Gliosis
- (iii) Other conditions producing lesions in striato-nigral pathways (Parkinsonism)
- a. Cerebrovascular disease
- b. Wilson's disease
- c. Head injury (punch-drunk syndrome)
- d. Meningovascular syphilis
- e. Carbon-monoxide poisoning

- f. Manganese poisoning
- (iv) Drug-induced Parkinsonism
 - a. Reserpine
 - b. Methyldopa
 - c. Phenothiazines
- 3. Pick's disease - rare cause of pre-senile dementia
- 4. Huntington's chorea
 - (i) Atrophy of caudate nucleus and putamen
 - (ii) Neuronal loss in frontal cortex gives rise to dementia and involuntary movements
- 5. Spinocerebellar degenerations
 - (i) Friedreich's ataxia
 - (ii) Carcinomatous cerebellar degeneration
 - (iii) Alcoholic cerebellar degeneration
 - (iv) Bassen-Kornzweig syndrome
 - a. Cerebellar ataxia
 - b. Fat retention in surface enterocytes of jejunum
 - c. Abetalipoproteinaemia
 - d. Acanthocytosis (red blood cells)
- 6. Motor neurone disease
 - (i) Progressive muscular atrophy - lower motor neurones
 - (ii) Amyotrophic lateral sclerosis - upper and lower motor neurones
 - (iii) Primary lateral sclerosis - upper motor neurones
 - (iv) Bulbar palsy - localised
- 7. Subacute combined degeneration of the cord. Demyelination of posterior and, later, lateral columns associated with pernicious anaemia

J. Tumours

The commonest cerebral tumour is a metastatic deposit.

Metastases arise from:

1. Carcinoma of bronchus, breast, kidney, gastrointestinal tract
2. Malignant in particular, but most malignant tumours metastasise to the brain.

Neuroectodermal tumours

1. Gliomas
 - (i) Astrocytoma: Grade. I-IV

(Grade IV equivalent to glioblastoma multiforme) Descriptive varieties of astrocytoma

- a. Fibrillary
- b. Pilocytic
- c. Gemistocytic

Sites

- a. Cerebral - usually found in adults. Variable growth rate and prognosis
 - b. Cerebellar - occurs in children. Usually pilocytic and complete removal generally results in cure
 - c. Spinal cord - difficult to treat with poor prognosis
- (ii) Oligodendroglioma
 - (iii) Ependymoma - develop from the lining of the ventricular system. Myxopapillary ependymoma arises from the filum terminate
 - (iv) Polar spongioblastoma (very rare)
2. Medulloblastoma
 3. Ganglioneuroma and ganglioglioma

Mesodermal tumours

1. Meningioma

Sites

- (i) Parasagittal
- (ii) Spinal cord
- (iii) Sphenoidal ridge
- (iv) Olfactory groove

Microscopic appearances

- (i) Transitional psammomatous
 - (ii) Meningothelial
 - (iii) Fibroblastic
 - (iv) Angioblastic (? haemangiopericytoma)
2. Neurilemmoma, e.g. of the VIII nerve, and dorsal spinal roots
 3. Haemangioblastoma - sometimes part of the von Hippel-Lindau syndrome
 4. Lymphoma
 - (i) Primary
 - (ii) Secondary

Tumours of developmental origin

1. Craniopharyngioma
2. Epidermoid and dermoid cysts
3. Chordoma

PERIPHERAL NERVES

Types of injury

1. Wallerian degeneration - demyelination and loss of the axon distal to the site of injury
2. Demyelination alone - i.e. survival of axons
3. Axonal degeneration (dying back phenomenon)

These types are seen to varying degrees in all the conditions listed below.

Mononeuropathy

Lesions of individual peripheral nerves

Aetiology

1. Penetrating injury
2. Traction
3. Compression
 - (i) External, e.g. tourniquet or crutch
 - (ii) Internal, e.g. carpal tunnel syndrome
4. Haemorrhage into the nerve
5. Infarction, e.g. in diabetes
6. Cold injury

Multiple mononeuropathy (mononeuritis multiplex)

Discrete lesions of several nerves arising simultaneously or in succession

1. Diabetes
2. Leprosy
3. Sarcoidosis
4. Polyarteritis nodosa
5. Amyloidosis

Polyneuropathy

Generalised involvement

1. Dietary deficiencies
 - (i) Chronic alcoholism

- (ii) Sprue
- (iii) Pellagra
- (iv) Beri-beri
- (v) Subacute combined degeneration

2. Related to infections

- (i) Acute post-infective polyneuritis (Guillain-Barré)
- (ii) Leprosy
- (iii) Diphtheria
- (iv) Infectious mononucleosis

3. Metabolic

- (i) Diabetes mellitus
- (ii) Uraemia
- (iii) Hepatic failure
- (iv) Acute intermittent porphyria
- (v) Amyloidosis
- (vi) Myxoedema

4. Vascular

- (i) Polyarteritis
- (ii) SLE

5. Toxic

- (i) Heavy metals
- (ii) Organo-phosphorus compounds
- (iii) Drugs, isoniazid and many others
6. Carcinomatous, especially bronchial
7. Heredofamilial disorders
 - (i) Peroneal muscular atrophy (Charcot-Marie-Tooth)
 - (ii) Hypertrophic interstitial polyneuritis (Dejerine-Sottas)
 - (iii) Hereditary sensory radicular polyneuropathy
 - (iv) Refsum's disease
 - a. Polyneuritis
 - b. Ichthyosis
 - c. Retinopathy

d. Deafness and anosmia

Tumours

Benign

- 1. Neurofibroma
 - (i) Solitary
 - (ii) Multiple - von Recklinghausen's disease
- 2. Neurilemmoma

Malignant

- 1. Neurofibrosarcoma
- 2. Malignant neurilemmoma
- 3. Ganglioneuroma autonomic nervous system
- 4. Ganglioneuroblastoma autonomic nervous system

Neuroblastoma

Hormesis is an application of the Arndt-Schultz law. Other fields of homeopathy have shown us applications of the law of initial values. Both of these are used to determine the laws of metabolism. The laws of reproduction utilize a different type of procedure.

In our reproductive emergent class of processes we have certain laws known as the first and second Mendelian laws of inheritance, the laws of cellular and tissue differentiation, and epigenesis. As an example, ontogeny recapitulates phylogeny. Gene duplicating operations to replication and information transfer happen through operations vs. operandi that can duplicate themselves with identical linear intervals.

Modern science has made phenomenological observations of the process of reproduction, and chemical attempts to explain this process have fallen tremendously short. The process of entropic thermodynamic chemistry could not possibly explain the reproductive process. Organized quantic control through some type of electrodynamic process, capitalizing on a computer-like precision and utilizing the long-range forces and virtual photon harmonic, is the only conceivable way to explain such a dynamic process as reproduction. This represents a very powerful threat to the entire chemical structure of synthetic pharmacology, and yet future generations will know and research this energetic connection.

In 1945 Schrödinger emphasized the importance of molecular stability and negative entropy in genetics. Negative entropy is information conservation. Expressed in rules given by Schrödinger, the quantum rule will produce a concept that like will produce like cycles, and that genetic information is thus conserved through the cyclic nature of the periodical movement of the transformations. This can happen through the restriction of the number of molecules in space and time, needed in the process of reproduction, and holding the reproduction process closed through its cycle.

Schrödinger has given us the idea that like will produce like through the reproductive cycle; Hahneman laid out the idea that like will treat like through the metabolic process. This is the

Arndt-Schultz law of pharmacology; the law of initial values of Wilder, and a point taken by other researchers of physiology and pharmacology.

In the closed process of reproduction we can see how like will produce like. In the open process of metabolism we can see how like might treat like. So a minute amount of an element could have a paradoxical reversal to a larger amount of it. This accounts for the phenomena of hormesis and homeopathy.

A proving in homeopathy is accomplished when a homeopath gives a substance to a group of people for a period of time, and then sits down and reports all of the symptoms they present. Then the homeopath will evaluate what commonalities are presented by the patients involved in this proving. It is then assumed by classical homeopaths that whatever this proving accomplishes, a minute amount of this homeopathic will reverse. This antiquated form of homeopathy has now proven to be incorrect. A more recent evaluation finds that there is more complexity, and that this paradoxical reversal happens in some items, but not in all. A new type of homeopathy is presented in this document, supported by a much higher degree of science.

Homeopathy

- 1. Allersodes
- 2. Sarcodes
- 3. Isodes
- 4. Nosodes
- 5. Combinations
- 6. Classical

WORLD-WIDE/YEAR AS OF 1992	SINTHETIC ALOPATHIC PHARMACEUTICS	NATURAL & HOMEOPATHIC PHARMACEUTICALS
Sales	\$300 billion	\$30 billion
Profits	\$150 billion	\$1 billion
Malpractice Suits	\$100 billion	\$100,000
Malpractice Settlements	\$30 billion	\$10,000
Percent of Damage Risk	12%	.0000001%

This addition of a super-flux of a chemical demanding action of the synaptic cleft is also highly profiting, since these chemicals can be synthetically derived and the synthetic process can be patented.

Inflammation

HOMEOPATHY THERAPY	ALLOPATHY THERAPY
Stimulation of Patient Defense System	External Intervention Interferes with Self Regulation Ferment, Blockages, Over-stimulation
Healing and Cure Through Release and Management of Poisons and Repair of Damage	Produces Dependency on Mostly Synthetic Chemicals Weakens Patient Defense System Through Lack of Use
Reestablishes Homeostasis	Produces Side Effects, Iatrogenic Damage, Lingering Diseases and Long-term Genetic Damage
Regressive Vicariation	Retro-Regressive Vicariation

INFLAMMATIONS

Part of the Defense Phase of Life

Sympathetic, Acidosis, Hyaluronidase,

Hydrolysis, Tissue Bouillon,

Hypertony, Histamine

HOMEOPATHY/NATUROPATHY (Wholistically Driven)	ALLOPATHY THERAPY (Symptom-Driven)
Defense Management	Suppression
Restoration of Homeostasis	Chemotherapeutics
Release of Etiology	Antibiotics, Antipyretics
Minimal Dose	Steroids, Anti-Inflammatories NSAID
System Balance Restored	Precipitate Develops as Biology Reacts to Synthetic Compounds Mega-Doses of Drugs Builds Dependency
System Release of Auto Toxins Reduced Cascades	Produces Wild (Illegal/Improper) Peptides (Overdose of Drugs) Induces Anti-Body Cascade
Proper Anti-Body Release	Produces Improper Auto Anti-Bodies
Cure	Produces Auto Aggression Disease Lupus, Arthritis, Asthma, etc.

GENERAL DETOXIFICATION AND PREVENTION

1. Procure a good source of water. Ordinary tap water must be double-filtered to remove most chlorine and fluorine. Activated charcoal filters are inexpensive and good (change filters once every 4 months to forestall bacteria buildup). Water processed by reverse osmosis is best, but daily output (on most available units) is limited. Distilled water is not recommended for long-term use because it is "dead" and may chelate and hasten excretion of essential metals. The addition of wetting agents to water makes a water that is helpful for cleansing and healing. Spring water is good, but be sure to have questionable sources checked for pollutants.
2. Avoid air pollutants. Make every effort to live and work away from the denser urban areas. If this is not possible, try to get away for several weeks a year (preferably to the mountains or to a clean ocean) to rebuild lung tissue. Use air filters or air ionizers in the home and office. If you exercise outdoors, do it during relatively low-pollution times such as very early in the morning or well after rush hour at night.
3. Avoid commercialized foods. Buy produce, grains and other staples from health food stores and co-ops at which the likelihood of obtaining foods grown in good soil is greater; or grow your own in healthy soil. Carefully wash produce from supermarkets: use soapy water or 0.2 ounces hydrochloric acid to 3 quarts of water. Place produce in the water for 5 minutes. Grains, beans, vegetables, fruits, nuts, sprouts and other simple foods are the best dietary staples. They are inexpensive, healthful, tasty, easy to prepare and ecologically sound. Seed products are best when sprouted. Cover with damp cloth for 24 hours, then dry. This washes away enzyme inhibitors.
4. Curtail the use of chemical sundries in the home. This includes cleaning fluids, insect repellents, garden sprays, air fresheners, detergents, dry cleaning fluids, etc. Try to obtain natural cleaners and solvents.
5. Improve your eating style. This means, in addition to eating the right foods, to avoid overeating (under-eating is best) and eat at the right times. The bulk of the day's food should be eaten before the early afternoon. Avoid big dinners after 6:00 p.m., they do not digest properly. Also, relax before and after meals. If you are upset or very tired, it is best to skip the next meal. Never eat or drink foods or beverages that are very hot or cold. If your hand cannot tolerate the temperature, neither can your stomach. Fluids alone, fruits alone, melons alone. Fresh and raw should be your guideline.
6. Exercise! Everyone needs vigorous exercise - at least 15-20 minutes three times per week, every day is better. Start with an easy program and build up. Jogging and swimming are good, and mini-trampolines are excellent if you are very much out of shape, or need something for indoors during the bad weather.
7. Embark on a basic supplementation program. Consult with your doctor and use basic protective food supplements daily. We highly recommend the following products.

"A-Z Formula": 2 tablets per day. Provides many trace elements and protective factors not found in ordinary foods. If there is iodine sensitivity, use "A-Z Formula minus Iodine". "A-Z Mega" may be used for the severely deficient person.

"Amino Acid Mineral Liquescence": 2 teaspoons per day. Provides all amino acids and minerals needed for life and detoxification.

"Fatty Acid Liquescence": 2 teaspoons per day. This contains all fatty acid components needed for life. Compensates for loss of nutrients from hybridization and cooking.

"Phosphatidyl Choline": 1-2 tablets per day. Provides essential fatty acids and helps keep cholesterol under control, while stimulating brain performance.

Yogurt: 1-2 cups per day (or use buttermilk, kefir, etc.). These fermented dairy products provide beneficial bacteria for colon health.

"B-Complex" and "Brain Liquescence": 1-2 teaspoons per day (use a natural RDA potency). Amounts above what can be obtained from food have preventive and protective value. Also "A-Z Formula", "A-Z Formula minus Iodine", or "A-Z Mega" in severe nutritional deficiencies.

"Vitamin C Liquescence": 2 teaspoons per day. A basic protective water-soluble vitamin.

"Vitamin A" and "Vitamin E": 5,000 IU and 100 IU respectively per day. These are two basic protective fat-soluble vitamins.

"Immune Stim" and/or "Oriental Cold and Flu": 1 bottle in the flu season as a preventative measure.

"Beautex": 10 drops 3 times a day. Exposure to beauty shop toxins.

"Algin": 10 drops once each day. For radiation exposure.

DETOXIFICATION

Ease of flow is wellness. Ease of flow involves the physical, the spiritual and the emotional. When disease starts, we get "Dis-Ease" of flow or blockage of flow. This usually starts with the inability to detox. If you do not detoxify, you cannot nourish. Work on detox first, then absorption, nutrients, mental attitudes, spiritual, social and finally education.

$$\text{Clearance (elimination)} = \frac{\text{hepatic clearance} + \text{renal clearance}}{\text{volume of water specific to the toxin}}$$

Kidney and liver function, and the amount of good water consumed, determine the clearance. The volume of water needed to facilitate removal of toxins varies with the toxin: monosodium glutamate, for example, requires much less water for its elimination than a lipid-soluble toxin such as, say, DDT.

We do know the clearance factor of a toxin is a mathematic relationship of hepatic clearances (liver added to the kidney clearance). This equation is over the water coefficient for each toxin. Each toxin has an amount of water that it takes to get rid of that particular toxin. For example: Valium is a pharmaceutical which has an H2O coefficient of two gallons. With approximately two gallons of water, you can rid your body of the normal dose of valium, provided your liver and your kidneys are working properly. The more water, the better your clearance. For some strange reason, we find that the liver has to have a better capacity to detox than the kidney, or detoxification does not work properly. The liver should be worked on before the kidney.

The clearance factor for DDT is only 50,000 gallons of water for what you have in your body right now. The big problem is you cannot stop your exposure to DDT. Everyone has five to seven percent of DDT in their bodies now, and that amount can only increase if we do not stop the use of insecticides and pesticides. DDT is only one of the many insecticides to enter our bodies. There is no way we can detoxify fast enough, to overcome the exposure. To detoxify you need good water, a good liver and good kidneys. These are the major keys to detoxification. The better the water, the better the detox. The better the liver, the better the detox. The better the kidneys, the better the detox.

It is our opinion that we can decrease the clearance factor of water needed to detoxify by using homeopathy.

XENOBIOTICS

"Xenobiotic" is a word used in classic biology and the World Health Organization to indicate toxic compounds. Not all toxic compounds come from the environment such as air and water pollution. Toxic compounds can be manufactured within the body. It is wrong to think that all toxins are derived from synthetic substances and external impacts. In fact, any nutrient can become a toxic problem if ingested in large amounts. Even water can be toxic, if we drink too much at one time.

Within the last hundred years, man, through synthetic development, has drastically increased

our toxic exposure, which now jeopardizes life itself. These toxins that have been generated from insecticides, herbicides, petroleum, etc. have had profound impact on biology. With this in mind, a new system of medicine for detoxification must be addressed.

This new system is also an old system, for it is homeopathy. Through ingestion of very, very small trace amounts of poisons, the body can have a paradoxical rebound effect. Present-day scientists have found in a new study of hormesis that tickle doses, small trace doses of a toxin, such as radiation, petroleum, synthetics and chemicals can have stimulatory effects on the human body.

At the University of Wyoming cell biologist, Joan Smith-Sonneborn, has found that tickle dosages of radiation have extended the life spans of flies, rabbits and other organisms, and Health Physics devoted its entire issue to the study of hormesis. As we can see, this allows for the understanding of what homeopaths have known for years; that a small amount of a toxic agent can have a beneficial result on the human organism.

Xenobiotics allow for the understanding of hormesis that modern science is starting to understand, opening the door for a new biology and a new modality of medicine, so that we don't try to demand action with large-dose pharmaceuticals, but tickle the life-force of the patient to respond and to normalize itself for health.

Detoxification of Xenobiotics

The detoxification of xenobiotics is important and should be a central issue in health care. Even slight toxemia can block the electron transport chain, upsetting enzyme function, disturb mitogenic radiation and overtax the eliminative functions. Meanwhile, the earth is being overrun with toxins i.e., air and water pollutants, insecticides and defoliants, radioactive wastes, etc., which threaten not only the individual's powers of detoxification but life itself. Health professionals are behooved to deal with this plague of xenobiotics on both the clinical level and the community or social levels.

Exposure to toxins starts at conception. Subtle toxins can penetrate the amniotic barriers and interfere with development. The figure at the bottom of the next page illustrates the prenatal periods during which organs are susceptible to serious damage from exposure to toxins. The ear is most sensitive, which probably accounts for the otitis and hearing disorders prevalent in our society.

Everyone has a toxic burden, consisting of their total accumulation of xenobiotics. When the toxic burden reaches a level that exceeds the power of the detoxicative mechanisms' ability to cope, a breakdown occurs. The breakdown usually occurs as a "last-straw" sort of situation: the toxic burden built up over decades is suddenly manifest by a superficially trivial exposure or event.

Dr. Reckeweg's Homotoxicology describes five levels of defense against toxins:

1. The reticuloendothelial system. This consists of the lymph system, white blood cells, macrophages and the humoral wing of the immunity (antibody development).
2. The pituitary/adrenal axis. This system is activated when the other systems are overloaded.
3. The neural reflex system. This includes the entire nervous system.
4. The liver. The liver performs an array of detoxicative functions with its oxidases and via the bile.
5. The mesenchymal system (connective tissue).

We might broaden Dr. Reckeweg's system #1 to include the skin and lungs, making system one representative of the instantaneous defense system. Kidney and other endocrine functions can be added to system 2. A new category, system 6, can be added to complete the list: the bowel, especially the bowel's flora. The bowel's flora shifts in response to the toxins it encounters. So-called "unfriendly" flora such as candida may actually be friends in disguise, since they help deal with toxins that might otherwise overwhelm the system. Yeasts, for example, are better equipped than bacteria to deal with heavy metals.

Identification and treatment of allergies or hypersensitivities, stress reduction, awareness training, physical culture such as exercise, yoga, etc., proper food and water, nutritional supplementation and others can reduce the toxic burden and avert health catastrophes. Also, cleaning the environment is helpful and, in some cases, mandatory. Toxins obey the second law of thermodynamics and tend to diffuse from areas of high concentration to areas of low concentration. Thus, if an individual can be removed from a toxin-laden environment, the toxins will eventually pass out of the system. This is always for complete healing and sometimes for noticeable results: if the individual has a severe hypersensitivity to a particular environmental contaminant, he must be removed from contact with it.

Detoxification can be speeded by good homeopathic prescribing and by nutritional supplementation. The latter are limited in their usefulness, but are good for fortifying the system and can act as chelating agents. Detoxification programs should last from three days to a month, depending on the individual case. After that you will need to rebuild tissues through improved diet, exercise, stress reduction and mental treatments. These phases of detoxification and rebuilding should be cycled for complete healing. We detox through the urine, the kidneys, the blood, the bowel, the liver, the small and large intestine, the breath, the lungs, the sweat glands and the skin. Mucous and sinuses are internal. They are meant as an internal drainage that should help tip us off if something is wrong. We must not forget the need to detox our mind, our spirit, our social and our environment.

There are five principal avenues of elimination. The function of each of them should be encouraged, along with the use of homeopathics.

1. Lungs. Naturally, most gaseous toxins exit the body via the lungs. Deep-breathing exercises and ion generators are valuable for disfunction.
2. Bowels. Most solid wastes exit the body via the bowels. Bowel function can be promoted with bulk laxatives (Mucovata, bran, etc.), peristaltic stimulants (herbal laxatives such as senna, cascara, etc., and the acetylcholine precursors choline and pantothenic acid), stool softeners, acidophilus, and enemas or colonics when necessary. Long-term use promotes dependency, robs potassium and depletes muscle tension.
3. Skin. While the skin is one of the most neglected avenues, encouragement of elimination by this route can be very advantageous. Exercise, saunas, sweat baths, swimming or any activity that breaks a sweat and opens the pores is beneficial.
4. Kidneys. The filtering of waste through the kidneys is vital. The primary requisite here is plenty of good water - energetically active, pure and well-oxygenated.
5. Mucous membranes. These dump toxins into the intestines for elimination and control parenchymal endothelial balancing of minerals.

Urine

Bowel

In stool analysis there are many different types of stools, and the quality of the stool can tell us much about the health of a person.

Steatorrhea can be found in a person by looking at the person's stool. In steatorrhea there is an inability to absorb fats, and an inability of the small intestine to make the proper enzymes to break down the fats, proteins, and carbohydrates. This will result in a stool which has some of the following characteristics:

1. The stool will be light in color.
2. It will float because of the high fat content.
3. It will be oily.
4. It will have a fowl smell because of the foods not able to be broken down, sometimes even containing undigested particles of food.

This might trigger us to use small intestine digestive aids to help in the digestion of the fats.

A silver or aluminum-colored feces, especially accompanied by jaundice, could come from a growth blocking the pancreas gland duct and warrants medical attention. This is an extreme case of steatorrhea.

An internal ulcer, which bleeds into the intestinal tract, will cause a black, crusty type of stool. This is due the heavy dose of hemoglobin that has formed in the stool. These individuals should take an ulcer formula such as "Ulcer" and be on a cabbage juice diets to help increase the vitamin K factor in the blood and heal the ulceration.

Black or tarry-colored stools, not related to large doses of iron, are suspicious evidence of bleeding in the gastro-intestinal tract. Sometimes taking large amounts of aspirin can cause gastrointestinal upset, and possibly even breaks or bleeding in the gastrointestinal tract.

Pencil-thin stools can sometimes be indicative of an allergic substance that has been eaten by the person, which causes a histamine-type release swelling of the tissues in the large intestine, and this swelling results in very thin stools. These thin stools, thus, can be indicative of an allergic reactivity to a substance that the person might have consumed.

To test for lactose intolerance, we should look for gastrointestinal symptoms that will disappear if the person avoids all milk products for four days. Then if the person drinks milk, and the symptoms recur, it will tell us that there is a possibility of lactose intolerance. Then by taking commercial lactate, or any other commercial products that are preparations of lactase with milk, we can see if that will help the situation so that we can further diagnose the lactose intolerance.

Greenish-type stools may be indicative of a problem with the bowel in the liver release.

An extremely fowl odor might be an indication of a parasitic infection, such as giardia, or possibly amoebae.

If the feces size seems to change, and has different consistencies, this could be a sign of an obstructed bowel.

Stool analysis can also reveal intestinal parasites, as we can look for worm eggs with a microscope using sugar solutions. (Occult) blood analysis can tell us about the possibility of colon-rectal cancer, red color in the feces can reveal visible blood, not just occult blood.

Tapeworms can come from eating raw, or inadequately-cooked meat, such as steak tartare, raw fish, and other sushi reparations. Most worm infestation comes from being barefoot on the ground or pavement where dogs have deposited excrement containing worms. Even where there are no breaks in the skin, these worms can get into the feet. Hookworms can complicate intestinal function and also cause anemia.

One test for tapeworms in a child can be accomplished by the "scotch tape" test on a glass slide. Every night for a week, take a piece of scotch tape, wait for about one and a half to two hours after the child has been under the warm blankets. Often times the worms will come out to lay their eggs at the anal area of the child. Wind the piece of scotch tape around the eraser end of a pencil, sticky-side out. Touch the sticky surface to the anal are of the child. Peel the scotch tape and put it onto a glass slide; look through a pocket microscope. You will see the pinworm eggs if they are there. A 30-power pocket microscope bought from Radio Shack can help to tell us about these different worm intruders. Pinworms are the number-one cause of appendicitis. Most of these eggs can be seen with the naked eye, but the microscope definitely helps. This child will also have itchy buttocks, and often times his nose will be itchy as well.

Giardia is so small that it cannot be seen with the naked eye, but it can sometimes be seen with the help of a 30-power pocket microscope.

The amount of the stool should be related to the amount of the diet. It is normal to have at least one bowel movement a day, sometimes two or three. To have one per meal is not irregular. If one has eaten large quantities of food and not had enough bowel movements, this might indicate a problem. Large quantities of grains, fruits, vegetables and other fibrous foods can often increase the amount of feces, while large amounts of proteins and liquids tend to decrease it. The color of the stool should be medium brown, and should be uniform in color throughout. Eating large amounts of green vegetables sometimes makes the stool green. Certain anti-biotics can cause a yellowish tinge. Food colorings, dyes, and drugs can also alter stool color. The consistency should be firm, not hard, or watery. Each segment should be from one half inch to one inch in diameter.

A diet high in fiber or not enough digestion will cause the feces to float. The normal pH of the stool should be close to 7, neutral. Large amounts of meat in the diet can make it more alkaline; large amounts of carbohydrates will make it more acid. There should be little evidence of glucose, no evidence of blood, white blood cells or parasites. Eating rare meat, certain vegetables and fruits, and vigorous brushing of the teeth are things that could cause a false, positive blood test of the stool.

Breath

Breath as a system of detoxification is the number-one system of fat removal in the body. We must depend on the pulmonary expertise of the heart and lung system for it to be able to detox.

There are several different ways in which we can measure the pulmonary ability of the system. An easy test to use for measuring the pulmonary function is that of walking one-half mile in six minutes. If, for example, a person finds himself out of breath after walking a few minutes, or after walking the one-half mile, it is reasonable to assume that there is a pulmonary function problem

that needs medical attention. A person should also be able to hold his breath a minimum of 40 seconds to be healthy; anything under 30 seconds indicates the need for medical attention. A good set of lungs should be able to blow out a candle at two and one-half feet. Anything less than two feet shows a problem with the pulmonary system.

Accompanying the breath is sputum, which can be analyzed as well. It can be analyzed for several different factors very easily. If there is a pink-tinged sputum, there might be some blood from the lung, possibly from an asthmatic who has a little bleeding in the lung. A rusty-colored sputum is sometimes an indication of pneumonia. Yellow sputum is a sign of bacterial infection, whereas green sputum might indicate sinus involvement, as well.

We can perform the match test by holding the mouth open as much as possible without puckering the lips, taking as deep a breath as possible and exhaling the air. A match held six inches from the open mouth should be easily blown out. Inability to successfully perform this test means that there is the possibility of a lung problem.

Another test is that of the forced expiration time test. With the mouth open as wide as possible, breathe in as deeply as you can and as forcibly and as fast as you can, exhale. You should be able to exhale out all the air within two to six seconds. If you take more than six seconds to push out all the air from your lungs, it is a warning signal that there might be an obstructive or restrictive problem within the lung.

Another factor that can be brought into analysis is that of breath odor. Halitosis, or bad breath can be significant of certain medical problems. Often times the valve at the top of the stomach, the cardia valve, is rotted away or has an inability to close. This will produce a putrid odor. Infections of the sinuses and teeth will produce halitosis without the complication of the hydrochloric acid smell. Sweet odors can tell us about improper spleen function. An acetone type smell can be a warning sign for diabetes. It might also appear, if someone is on a reducing diet or has too few carbohydrates. This can produce ketosis. If combined with yawning, this means that the person has slipped into a ketonic acidosis, which could be risky. Advise this person to eat some carbohydrates, such as fresh fruit. See if it brings energy to the system.

An ammonia breath odor can be the first sign of a kidney or possible liver disease.

A frothy type sputum can be a clue that there is heart failure or possibly lung edema, showing that the heart is performing inadequately.

If there are little pieces of chalk-like substance in the sputum that are actually calcium, this could be an indication of a fungus infection of the lung, or the consequence of exposure to certain minerals or silicosis.

Carbon monoxide can accumulate in the system and block oxygenation. It will drastically limit estrogen production and also limit testosterone production in males. Many forms of impotence are complicated by a decrease in oxygenation by a carbon monoxide blocking. This happens particularly in smokers. Decrease in sexual drive in either men or women can be a sign that there is carboxyhemoglobin, which means that carbon monoxide has taken the place of oxygen in the blood.

Carbon monoxide testers can be bought from the American Gas and Chemical Company, North Vale, New Jersey, 07647. For \$35 a package of twelve tests can be ordered, which will change

color in the presence of carbon monoxide. Thus, smokers and other people who might be at risk of carbon monoxide poisoning might want to buy this valuable kit.

Sweat

A lot of people do not sweat enough and some people sweat too much. For the most part, women do not naturally sweat as much as men. But women should sweat. Everyone should sweat. If a person is doing strenuous exercise and not sweating, it is probably the lungs that need to detoxify.

Often times excess saltiness in the sweat, especially in children, can be indicative of cystic fibrosis, which is a disturbance of the pancreas and its ability to generate different types of enzymes. Thus, a person cannot properly digest different compounds and this results in excess saltiness in the skin. We can taste the skin of our children, and if we can detect cystic fibrosis early enough, we can sometimes save these children, through different types of dietary procedures.

Sticky sweat can show a problem in the utilization of water, which might be significant at early-stage kidney or bladder dysfunctions.

Excess odor of the sweat, as in underarm odor, can also be a dysfunction of dietary involvement, showing that there is too much red meat or too many toxins in the diet. Also this odor can be complicated by different bodily infections. Some of these are stubborn and resist the soap of the washer and dryer. Sometimes these clothes need to be even microwaved at high temperatures in order to kill the different fungi and bacteria that the washer and dryer might miss.

Use of anti-perspirants which involve aluminum can contribute to Alzheimer's and other systemic problems. Use of other deodorants which block the release of sweat can sometimes cause problems with blood pressure and other detoxifying systems. To fight excess body odor we should clean up our diet, reduce our stress, and lead more natural lives.

Detoxification through the Endocrine System

Toxic Endocrine

Endocrine Gland	If Toxic, System Used to Detox
Adrenal	Lungs
Thyroid	Skin
Pineal	Eyes
Pituitary	Sinuses
Hypothalamus	Psyche
Gonads	Genitalia, Urine
Kidney	Urine
Stomach	Stool
Liver	Stool
Thymus	Sweat

Sweat glands are the back up of the thyroid. A sweat problem usually involves the thymus and the thyroid. If there a sinus problem, the pituitary is usually involved. A problem in the lung is an indication that there is a problem in the adrenal gland. A bowel problem indicates a problem in the large and small intestine or a weak liver. If there is a urine problem, the kidneys may be weak. Drainage of the eyes indicates the pineal gland is weak.

Homeopathic glandulars of the endocrine system are recommended to help in the detoxification of the glands.

General and ancillary support during a detoxification program includes balancing of the autonomic nervous system, provision of ergodizing agents, treatment of allergy/ hypersensitivity and mental treatment (stress reduction, etc.). Keep in mind that the body's effort to detoxify itself can be stymied by inappropriate mental or emotion habits: repressed feelings will express eventually as an increased toxic burden.

Following are outlines of suggested detoxification programs. As always, such programs must be modified or combined to suit an individual case.

Detox Program - Number 1

Detox program #1 is for toxicity in the reticuloendothelial system or combinations of them.

Vitamins and Minerals: Ascorbic acid, one gram (or more); Vitamin A 25,000; RNA/B-12/Folic Acid, 2 tablets/capsules; Chelated Cell Salts; Garlic; per day.

Glandulars: Homeopathic Lymph; Immune Stim; Spleen (6x, 12x, 30x, 60x, 100x combination) as directed.

Botanicals: Red clover; plantain; nettles; prickly pear; lobelia; marigold; Garlic extract.

Others: If infection is present, "Blood Liquescence", "Lymph Liquescence" is recommended.

NOTE: Cleansing the lymph and blood may temporarily stimulate candida growth. If this problem already exists, warn the patient of possible flare-up.

Detox Program - Number 2

Detox program #2 is for toxicity of degree and duration that has called into action the endocrine system.

Vitamins and Minerals: Vitamins A; C and E daily (roughly 25,000 IU, 2-3 grams and 100-200 IU, respectively). Chelated Cell Salts. Others: iodine; chromium; selenium; manganese and molybdenum.

Glandulars: Homeopathic Lymph; Spleen; Mammary; Parathyroid; Pancreas; Adrenal Prostate; Pituitary; Thymus; Thyroid (at 6x, 12x, 30x, 60x, 100x combination) as directed.

Botanicals: Scullcap; echinacea; mullein; kelp; black radish; alfalfa.

Others: "Phosphatidyl Choline" and "Essential Lipoids Garlic Oil " if infection is present.

NOTE: Always treat the digestive system. Support with HCl, enzymes, etc. to reduce the workload of the pancreas. Encourage consumption of legumes. Balance the pH, autonomic nervous system and hormones.

Detox Program - Number 3

Detox program #3 is for toxicity of degree and duration that has called into action the nervous system.

Vitamins and Minerals: B or G complex. Chelated Cell Salts.

Glandulars: Homeopathic Major Nerves; Pituitary; Metab; Brain (at 6x, 12x, 30x, 60x, 100x) as directed.

Botanicals: Scullcap, plantain, lily of the valley, black radish, alfalfa.

Others: "Phosphatidyl Choline, Lecithin ", "Vitamin C Liquescence", "Fatty Acid Liquescence".

NOTE: Chiropractic care and TMJ management are vital here. Balance the autonomic nervous system and reduce stress as much as possible. Encourage 24 hour fasts, one day per week.

Detox Program Number - 4

Detox program #4 may be the most important. In extreme toxicities, it is the starting point. It deals with the liver, whose detoxicative abilities are vast. The liver conjugates xenobiotics with various organic compounds to facilitate elimination.

Vitamins and Minerals: Ascorbic Acid, one gram 3-8 times per day; Vitamins A and E, daily (roughly 25,000 IU and 100-200 IU, respectively). Choline and Inositol as a lipotrope. Selenium; Manganese; Zinc; Copper; Molybdenum; Iron; Chelated Cell Salts.

Glandulars: Homeopathic Liver/Gallbladder; Stomach/Pancreas (at 6x, 12x, 30x, 60x, 100x combination) as directed.

Botanicals: Walnut; Blue Vervain; Scullcap; Wild Yam.

Other: "Fatty Acid Liquescence"; Intestinal Cleanse; "Phosphatidyl Choline"; "Liver Liquescence"; "H.E.P.A."; "Vermex".

NOTE: A liver flush is always indicated. As always, homeopathics of toxic agents should be identified and prescribed.

Detox Program Number - 5

Detox program #5 is for detoxification of the connective tissue. there are circadian shifts from acid to alkaline that occur in humans, one purpose of which is to contract and expand the connective tissue to expel toxins. Subtle inflammation of these tissues is thus natural and normal. Dilution is one of the first stages of resistance to toxins. Inflammation should be viewed as a process of dilution, local tissue edema. If the toxins are not adequately disposed of the inflammation becomes less subtle, eventually becoming perceivable.

Vitamins and Minerals: Vitamins A; C and E, daily (roughly 25,000 IU, 2-3 grams and 100-200 IU respectively). Chelated Cell Salts; Manganese.

Glandulars: Homeopathic Muscle/Ligament/Cartilage; Adrenal; Bone (at 6x, 12x, 30x, 60x, 100x combination) as directed.

Other: Essential Fatty Acids, Pantothenic Acid; Lymph Liquescence; Anti-Inflammation.

NOTE: Large doses of antioxidants are helpful for achieving rapid control of inflammation;

antioxidants are also needed for long-term connective tissue healing. Avoid most polyunsaturates, since most of these fatty acids are precursors of the pro-inflammatory prostaglandins. Aspirin and other non-steroidal anti-inflammatory drugs act by blocking prostaglandin production. It is important also to curtail animal protein intake, treat allergies and reduce stress.

Detox Program - Number 6

Detox program #6 is for detoxification of the bowel and, following that, reinoculation of the bowel with beneficial bacteria.

Vitamins and Minerals: B-12; Pantothenic Acid. Pantothenic acid and choline precursor acetylcholine, a helpful neurotransmitter if the bowel is atonic.

Glandulars: Homeopathic Small and Large Intestine; Thymus (6x, 12x, 30x, 60x, 100x combination) as directed.

Botanicals: Marshmallow root

Other: Intestinal Cleanse; "Disodium Phosphate"; Chlorophyll; "H.E.P.A."; "Liver Liquesence"; "Immune Stim"; "Digestive Liquesence".

NOTE: Always check first for worms, fungi (candida especially) or other intruders. If candida is present, treat with FNG and support with Vitamin A, and iron.

Detoxification is very important. In order to detox properly, the liver, kidneys and small and large intestine must be in good condition. The liver should be the first concern, then the kidneys, then the small intestine.

Liver Detoxification

Liver and Gallbladder Flush: Drink two or three glasses of apple juice or apple cider a day, for two or three weeks before the liver flush. If allergic or intolerant to apple juice, switch to a lime or grapefruit juice. Drink one glass of grapefruit juice in the morning for the same three weeks. Grapefruit juice detoxes the gall bladder and lowers cholesterol. Patients often mistake the detox reaction of grapefruit juice for some acid intolerance, while actually it is removing toxins. To remove a splinter there is some pain. The same with some systemic toxins, so patients must be encouraged to tolerate some detox reaction. Stones only form in the body when magnesium is in excess or deficiency. If the patient has not been consuming large quantities of magnesium then suspect magnesium deficiency syndrome, it is quite common. Supplement 25 to 100 mg per day. Too much more magnesium can cause hypoadrenia over a long time.

- A. Eat a meal early enough in the evening to allow time for following the steps.
- B. Three (3) hours later take one (1) teaspoon of Disodium Phos. in 2 oz. of water.
- C. One (1) hour later, repeat B.
- D. One (1) hour later, take 1/2 cup of lemon juice with 4 tablespoons of olive oil.
- E. Go to bed. Lay on your right side for 1/2 hour.
- F. Next morning on an empty stomach repeat B.
- G. If the next morning, there is no bowel movement, do an enema.

Liver Program: "Liver Liquesence" - 3 teaspoons per day; "H.E.P.A." - 3 pills at bed time. Do this for 3 weeks. "Digestive Glandular General" - 1 with meals for one week. "Liver/Gallbladder" - 10 drops, 3 times a day, 1 bottle. "Oriental Herb (Liver)" - 5 drops for 3 days.

Gallbladder Detoxification

"Liver/Gallbladder" and "Bear Gallbladder" homeopathics are recommended for gallbladder conditions along with magnesium and cholesterol management. Take - 10 drops, 3 times a day.

Kidney Detoxification

The "Kidney Liquesence" is recommended to clean up the kidney. Take 2 teaspoons per day.

Kidney Stone Flush: Do this until the stones are dissolved, but not for more than 6 weeks.

"Kidney, Adrenal, Ovarian or Prostrate" - 10 drops, 3 times a day.

"Oriental Herb (Kidney)" - 10 drops, 3 times a day, for 1 week.

"Kidney Stone" homeopathic - 10 drops, 3 times a day.

100 milligrams of B6

100 milligrams of Magnesium

into 10 oz. glass of

1/3 apple juice

1/3 lemon juice

1/3 juniper tea - 2 glasses a day.

Lymph Detoxification

Lymph should be worked on next. When there is build up in the lymph, this can be a sign of bad quality protein. When lymph starts to build up bad protein, it goes into the blood. Everyone should have some neurolymphatic work done on them. This will help to help stimulate the cleaning of the lymph. "Lymph Liquesence" is recommended for clogged lymphs. "Blood Liquesence" not only satisfies the anemia person, but helps with bad skin due to bad lymph and blood. It also contains lymphatic cleansers.

Lymph Program: "Lymph Liquesence" - 8 teaspoons (day 1); 7 teaspoons (day 2); 6 teaspoons (day 3); 5 teaspoons (day 4); 4 teaspoons (day 5); 3 teaspoons (day 6); Level off with 2 teaspoons per day. "Digestive Enzyme Liquesence" with meals. "Digestive Glandular (Fat, Protein, Carbohydrates)" - 2 each before bed on an empty stomach. "Lymph, Spleen, Mammary" - 10 drops, 3 times a day. "Oriental Herb (Lymph)" - 10 drops, 2 times a day, for 2 weeks.

Intestinal Cleanse Program

For 10 days to 2 weeks: "Small and Large Intestine" - 10 drops, 3 times a day. "Health and Beauty Poulitice" - 1 tablespoon in 6 ounces of water or juice, in the morning and at night. Seventy percent of diet should consist of raw fruits and vegetables (avoid iceberg lettuce and popcorn). "Herbal Laxative" - 1 with meals. Thirty ounces of filtered water (with the "Homeopathic Catalyst Water" added) should be drunk each day. "Essential Lipoid Factor" - 3 capsules with evening meal. "Fiber Capsule" - 2 capsules, 30 minutes before meals.

Activated charcoal and the intestinal cleanse program are very good for a person with a problem in the large intestine. Activated charcoal is not only used in therapy, but in diagnostic testing. It informs us of transit time. Calculate when your normal bowel movement takes place. Say you normally have a bowel movement around 9:00 a.m. Figure back 14 hours because normal transit time should be around 14 to 16 hours in the body. Counting back 14 hours, calculates to 7:00 p.m. the day before. Take the activated charcoal with a little bit of food at 7:00 p.m. and wait to see, if the next morning, the charcoal appears in the stool. If the charcoal is in the stool, it is a good indication that transit time is 14 hours away or less. Now, if the next morning the charcoal is not in the stool, then you know that the transit time is over 14 hours. The next time instead of taking the activated charcoal at 7:00 p.m., take it at 3:00 p.m. and wait to see when the charcoal appears. Do this one time during a week. If the activated charcoal does not appear in 24 hours, when does it? You will find certain people think their transit time is normal. Truth of the matter is, their transit time is 24 hours or 36 hours. They are just passing today what they ate a couple of days ago. Canned corn may be substituted for the activated charcoal to check transit time. If your transit time is too fast, your minerals will not be absorbed.

This program should not be performed for more than one week every three months.)

Not only does activated charcoal help to eliminate toxicity in the body, but it also measures transit time.

THE *Angel of God*
DESIRÉ SAYS

The World is contained
in our Minds...
to Change the World we
must change
the Way We Think

If you want things to be
Different then
Something Must
Change

Repetition is the key to
change...

